

The History of Liquid-Crystal Displays

HIROHISA KAWAMOTO, FELLOW, IEEE

Invited Paper

The modern history of liquid crystals has been dominated by the development of electronic displays. These developments began in 1964, when Heilmeyer of RCA Laboratories discovered the guest-host mode and the dynamic-scattering mode. He thought a wall-sized flat-panel color TV was just around the corner. From that point on, twisted-nematic (TN) mode, super TN mode, amorphous-Si field-effect transistor, and room-temperature liquid crystals were developed. In the beginning, liquid-crystal displays (LCDs) were limited to niche applications such as small-size displays for digital watches, pocket calculators, and small handheld devices. That all changed with the development of the notebook computer industry. In 1988, Washizuka et al. of Sharp Corporation demonstrated an active-matrix full-color full-motion 14-in display using a thin-film-transistor array. The electronics industries now recognized that Heilmeyer's 25-year dream of a wall-hanging television had become reality. LCDs could be used to replace existing cathode ray tubes. Through the cooperation and competition of many electronics giants, the LCD industry was firmly established.

Keywords—Active matrix, amorphous silicon, azoxy, birefringence, cholesteric, cyanobiphenyl, dielectric anisotropy, digital watch, DSM, DSTN, ester, Fergason, Gray, guest host, Heilmeyer, Helfrich, history, LCD, liquid crystals, MBBA, Nehring, nematic, PCH, pocket calculator, poly silicon, Raynes, rubbing, Schadt, Scheffer, Seiko, Sharp, STN, TFT, TN mode, transmission minimum, Wada, wall-hanging television, Washizuka, Williams domain, Yamazaki.

I. INTRODUCTION

The development of liquid-crystal displays (LCD) proceeded from early successes like the pocket calculator to the major milestone of a flat-panel television display you can hang on a wall. The history of that development spans the world's major industrial centers: the U.S., Japan, and Europe. I was fortunate to be a part of that history. When I joined RCA Laboratories at the David Sarnoff Research Center in April 1970, RCA was curtailing its efforts in liquid-crystal activities, but I had the opportunity to witness the developments there before the program's group head, George Heilmeyer, left for Capitol Hill as a White House

Fellow. Then, in 1985, I joined the Sharp Corporation in Japan and met Tomio Wada, the man who developed the world's first liquid-crystal product, a pocket calculator, in 1973. At Sharp, I also witnessed major development efforts in LCDs at the Tenri Advanced Development Center. In 1990, I participated in the founding of the European Laboratories at Oxford, U.K., and in 1992, we welcomed Peter Raynes, known for his contributions to the applications of cyanobiphenyls, to the Laboratories. Through discussions with him, I learned about the achievements of British and European scientists.

The modern history of liquid crystals is predominantly the history of the development of electronic displays made of liquid crystals. The developments started when a dynamic-scattering mode (DSM) was discovered in 1964. Manufacturers of LCDs had been minor-league members of the electronic display industry and served a niche market, supplying small-size displays primarily to pocket calculators and digital watches. A major milestone was reached in 1988 when a 14-in active-matrix (AM) thin-film-transistor (TFT) display was demonstrated. The electronics industries then recognized that the dream of a wall-hanging television had become a reality, thus, promoting LCD manufacturers to the "major leagues" in the electronics industry. By 2000, the LCD industry had caught up to the giant cathode ray tube (CRT) industry. In this paper, I focus on the 25 years of LCD developments that gave birth to the present-day LCD industry. In writing this paper, I interviewed 37 scientists and engineers scattered throughout the world. Each section of the article concentrates on a key technical item that led to the ultimate goal—the flat-panel television.

What had been an obscure general and scientific curiosity for 80 years suddenly became the center of attention as the result of a new invention, spawning a new industry projected to reach 40 billion dollars by the year 2006. The history of LCDs is a story of the hard work, disappointments, and successes of worldwide competition and cooperation that encompassed the U.S., Europe, and Japan. Each industrial center contributed its particular strengths: in America, it was the quickness of forming new ideas and demonstrating their feasibility; in Europe, it was the fundamental science

Manuscript received October 20, 2000; revised August 3, 2001.

The author is with Silicon Image Inc., Nara Gakuen-Mae, Japan (e-mail: kawamoto@zc4.so-net.ne.jp).

Publisher Item Identifier S 0018-9219(02)03951-8.

0018-9219/02\$17.00 © 2002 IEEE

and synthesis of basic materials; and in Japan, it was the process of perfecting implementation and moving it to the production line.

II. DISCOVERY OF LIQUID CRYSTALS AND THEIR FUNDAMENTALS—THE NAME “LIQUID CRYSTALS” WAS BORN IN GERMANY

As a material's temperature is raised, it generally changes state from solid to liquid to gaseous. It is generally believed that an Austrian botanist, Friedrich Reinitzer [see, e.g., Fig. 1(a)], first observed liquid crystals in 1888. He discovered a strange material that exhibited a mesophase between solid state and liquid state [1]. At a temperature of 145 °C, it melted, becoming cloudy white and viscous. At a temperature of 179 °C, it became isotropic and clear. The material he discovered was cholesteryl benzoate. On March 14, 1889, he wrote a letter to Otto Lehmann [see, e.g., Fig. 1(b)], Professor of Physics at the Technical University Karlsruhe of Germany, telling him about the two melting points. Lehmann studied the material and discovered that the liquid at the mesophase exhibited a double refraction effect, characteristic of a crystal. Because it shared characteristics of both liquid and crystal, he named it “fliessende krystalle” and the name “liquid crystal” was born [2].

Liquid crystals were not popular among scientists in the early 20th century and the material remained a scientific curiosity for 80 years. It should be noted that E. Merck of Darmstadt, Germany, sold liquid crystals for analytical purposes as far back as 1907 (see Fig. 2). In the early 1960s, only a few institutions and corporations were known to have been carrying out research on liquid crystals. The prerequisites for designing liquid crystals with specific physical properties hardly existed, not to mention the lack of motivation to use it in a commercial product. Liquid crystals were unknown to the man on the street.

A. Thermotropic and Lyotropic Liquid Crystals

The liquid crystals Reinitzer discovered by varying their temperatures are called thermotropic liquid crystals (see Fig. 3). As the temperature is raised, their state changes from crystal to liquid crystal at temperature T_1 . Raising the temperature further changes the state from liquid crystal to isotropic fluid at temperature T_2 . Generally speaking, the process is reversible by lowering the temperature, though there may be a small temperature hysteresis; the T_1 value when reducing temperature may be slightly less than the T_1 value when increasing temperature. The T_1 is sometimes referred to as the “freezing” temperature and T_2 as the “clearing” temperature. For the case where a liquid crystal is of nematic type as will be discussed later, the T_1 is designated by T_{CN} and T_2 by T_{NI} .

Another liquid crystal exists. It is called the lyotropic liquid crystal. This exhibits liquid-crystal behavior when it reacts with water or a specific solvent [4]. For example, the wall of a biological cell is made of lyotropic liquid crystals. Many biological structures such as the brain, nerve system, muscle, and blood contain lyotropic liquid crystals.



(a)



(b)

Fig. 1. Scientists who discovered liquid crystals. (a) Friedrich Reinitzer (1857–1927). (b) Otto Lehmann (1855–1922). (Historical Exhibition, the 12th International Liquid Crystal Conference, Freiberg, Germany, August 15–19, 1988).

The lyotropic liquid crystals are primarily investigated in the fields of biochemistry, biophysics, and bionics. We will leave the discussion of lyotropic liquid crystals to other publications while we focus on thermotropic liquid crystals.

C. Merck

Chemische Fabrik • Darmstadt

empfiehlt alle gangbaren Präparate
zur Demonstration der Eigenschaften

flüssiger und fließender Kristalle,

ferner sämtliche

Chemikalien für analytische Zwecke

insbesondere:

Garantiert reine Reagentien,
Volumetrische Lösungen,
Indikatoren und Farbstoffe

für analytische und mikroskopische Zwecke,

Chemikalien und Lösungen

zur Trennung von Mineralgemischen,

Reagenz- und Filtrierpapiere,
Mineralien-Sammlungen.

• • •

Zu beziehen durch die Grossdrogenhandlungen

Fig. 2. Liquid crystals sold as far back as 1907 for analytical works in research laboratories. Courtesy of Ludwig Pohl.

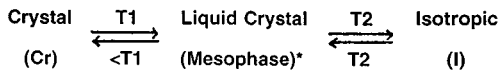

where $T_2 > T_1$

* A SINGLE PHASE OR A SEQUENCE OF PHASES

CRYSTAL----- PERFECT 3-D ORDER

LC STATES----- INTERMEDIATE DEGREES OF ORDER

ISOTROPIC -----TOTALLY DISORDERED

Fig. 3. Thermotropic liquid crystal [3].

B. Cigar-Like and Disc-Like Molecules

There are two types thermotropic liquid crystals. One type has cigar-like molecules, while the other has disc-like molecules and is referred to as "discotic" (see Fig. 4). Both types are mostly organic, as seen from the formulae of the examples given. The liquid crystals used in electronic displays are primarily of the cigar type. In this article, therefore, we concentrate on thermotropic liquid crystals made of cigar-like molecules. Only in the late 1990s did the discotic molecules find an application in electronic displays. They are used to make a sheet of film that expands the viewing angle of a twisted-nematic (TN) display.

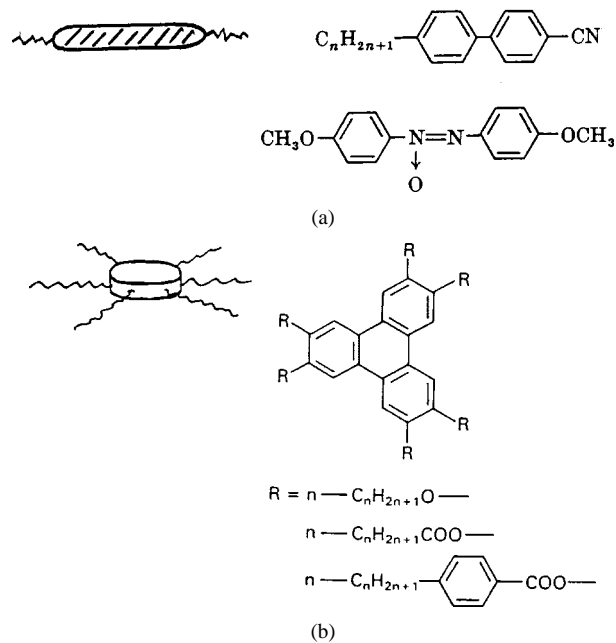

Fig. 4. (a) Cigar-like and (b) disc-like molecules [3].

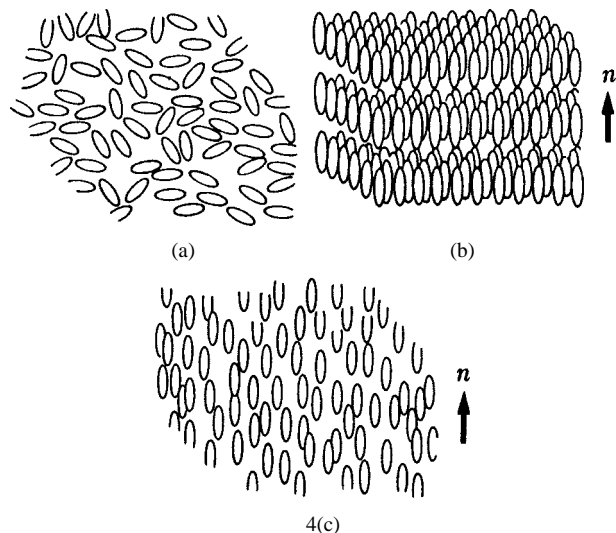

Fig. 5. Molecular alignments in liquid and liquid crystals. (a) Liquid. (b) Smectic. (c) Nematic.

C. Thermotropic Liquid-Crystal Types

There are three types of thermotropic liquid crystals. These are based on a system proposed by G. Friedel in 1922 [5]. They are smectic, nematic, and cholesteric types.

1) *Smectic Liquid Crystals*: Smectic comes from a Greek word meaning grease or clay. In smectic type liquid crystals, the cigar-like molecules are arranged side by side in a series of layers as shown in Fig. 5(b). The long axes of all molecules in a given layer are parallel to one another and perpendicular to the plane of layers. The layers are free to slip and move over each other. The smectic state is viscous, but fluid and ordered.

2) *Nematic Liquid Crystals*: Nematic comes from a Greek word meaning thread-like. Under a microscope using polarized light, nematic liquid crystals appear as thread-like structures. In the nematic state, the molecules are not as

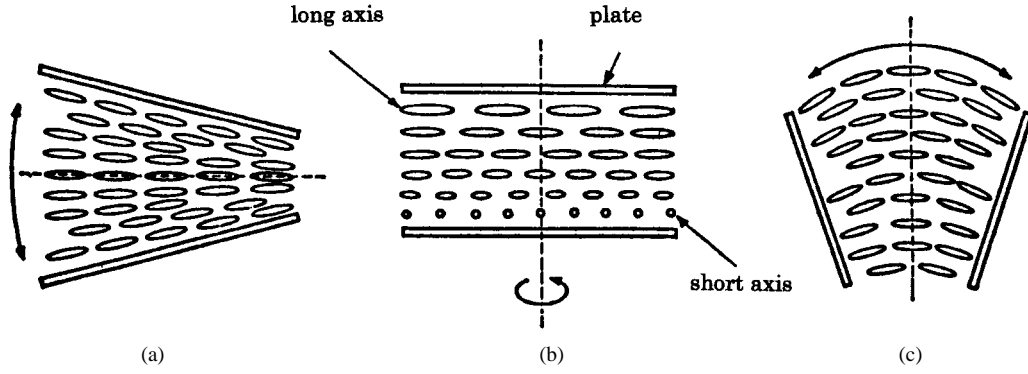

Fig. 6. Three molecular alignments of nematic liquid crystals [4]. (a) Splay. (b) Twist. (c) Bend.

highly ordered as in the smectic state, but they maintain their parallel order [see, e.g., Fig. 5(c)]. On average, the nematic liquid crystals are aligned in one direction. The direction is represented by a vector n called a director. Liquid crystals used in electronic displays are primarily of the nematic type.

Because of its specific molecular alignment, nematic liquid crystals exhibit anisotropic physical characteristics; their refractive index, dielectric constant, permeability, electrical conductivity, and viscosity measured in the direction of the long axis are different from those measured in the plane normal to the long axis. In nematic liquid crystals, the refractive index along the director axis is almost always larger than along the perpendicular axes. The electrical conductivity along the director axis is generally larger than along the perpendicular axes. The permeability is generally negative and its absolute value along the director axis is smaller than along the perpendicular axes.

3) *Cholesteric Liquid Crystals*: These materials are discussed later in this section.

D. Elasticity

Under mechanical stress, liquid crystals deform their molecular alignment. The deformation of nematic liquid crystals can be considered for three cases, shown in Fig. 6. The first is a “splay,” where molecules are spread by external stress, the second is a “twist” where molecules are twisted by an external stress, and the third is a “bend” where molecules are bent by an external stress. The relationship between the deformation and stress is expressed respectively by splay elasticity k_{11} , twist elasticity k_{22} , and bend elasticity k_{33} .

The elasticity of liquid crystals is of the order of 10^{-6} to 10^{-7} dyne and is much lower than that of ordinary elastic material. This makes alignment modification of liquid crystals by the application of electrical field, magnetic field and external stress much easier. The density of free elastic energy for nematic liquid crystals under deformation is expressed by [4]

$$f_d = \left(\frac{1}{2}\right) k_{11}(\text{div } n)^2 + \left(\frac{1}{2}\right) k_{22}(n \bullet \text{rot } n)^2 + \left(\frac{1}{2}\right) k_{33}(n \times \text{rot } n)^2. \quad (1)$$

E. Dielectric Anisotropy

Regarding the dielectric constant, there are two types of nematic liquid crystals. One is called positive dielectric anisotropy (p-type) and its dielectric constant along the director axis is larger than that along the axes perpendicular to the director [4]. The $\Delta\epsilon$, which is equal to $\epsilon_{\text{parallel}} - \epsilon_{\text{perpendicular}}$, is in the range of +10 to +20. The other type is called negative dielectric anisotropy (n-type) and its dielectric constant along the director axis is smaller than that along the axes perpendicular to the director. The $\Delta\epsilon$ is in the range of -1 to -2.

Applying an electrical field E to the liquid crystals, there appears an electrical energy f_e , where

$$f_e = -\left(\frac{1}{2}\right) \epsilon_{\text{perpendicular}} \epsilon_0 E^2 - \left(\frac{1}{2}\right) \Delta\epsilon \epsilon_0 (n \bullet E)^2. \quad (2)$$

Here, the first term is independent of the director n . The second term changes value depending on the direction of n . When $\Delta\epsilon$ is positive (p-type liquid crystal), the application of an electrical field greater than some certain critical value ($E > E_c$) aligns the long axis of the molecules parallel to the direction of the electrical field E . This happens because the electrical energy f_e is minimized when the director n is parallel with the electrical field E . On the other hand, when $\Delta\epsilon$ is negative (n-type liquid crystals), the long axis of molecules aligns perpendicular to the electrical field because the electrical energy is minimized when n is at a right angle to E . Therefore, by applying an electrical field, we can control the direction of nematic molecules.

Consider the case when the alignment of molecules is such that the liquid crystals have been in their lowest energy state and an electrical field is then applied. The total free energy F of the liquid crystal is expressed by the summation of electrical energy f_e and elastic energy f_d

$$F = \text{Integration} [f_e + f_d] d\tau. \quad (3)$$

An important case in applications occurs when nematic liquid crystals are sandwiched by two parallel plates and the electrical field is applied normally to the plates. A critical field E_c that causes the transition of the molecular alignment can be expressed by

$$E_c = \left(\frac{\pi}{d}\right) \left(\frac{k_{ii}}{|\Delta\epsilon \epsilon_0|}\right)^{1/2} \quad (4)$$

where d is the spacing of the plates. When the base state of the molecular alignment is homogeneous, $k_{ii} = k_{11}$ and when the alignment is twisted, $k_{ii} = k_{11} + (k_{33} - 2k_{22})/4$. When the liquid crystals are positive and the alignment is twisted as shown in Fig. 6(b), the threshold voltage for transition is

$$V_C = \pi \left[\frac{k_{11} + \frac{k_{33} - 2k_{22}}{4}}{|\Delta\epsilon\epsilon_0|} \right]^{1/2}. \quad (5)$$

F. Birefringence

Because of its double refraction or birefringence property, a liquid crystal exhibits the following optical characteristics [4].

- 1) It redirects the direction of incoming light along the long axis (director n) of the liquid crystal.
- 2) It changes the state of polarization (from linear, ellipse, or circular polarization to one of linear, ellipse and circular polarizations) and/or changes the direction of polarization.

Liquid crystals are not as rigid as solids and are easily re-oriented, realigned, or deformed by applying electrical fields, magnetic fields, heat, and/or mechanical stresses. Accordingly, the optical characteristics based on the birefringence are easily affected. These make nematic liquid crystals attractive for use in electronic devices. The following sections trace the history of how scientists and engineers used such characteristics of nematic liquid crystals to construct electronic displays.

G. Cholesteric Liquid Crystals

The term cholesteric is used because the molecular structure of the liquid crystals characteristically has a large number of compounds containing cholesterol [6]. The molecules in cholesteric liquid crystals are arranged in layers (see Fig. 7). Within each layer, molecules are aligned in parallel, similar to those in nematic liquid crystals. The molecular layers in a cholesteric liquid crystal are very thin, with the long axes of the molecules parallel to the plane of the layers. A special aspect of the cholesteric structure is that the director n in each layer is displaced slightly from the corresponding director of the adjacent layer. The displacement is cumulative through successive layers, so that the overall displacement traces out a helical path. Because of the helical structure, it exhibits such interesting phenomena as optical rotation, selective reflection and two-color circular polarization.

The phenomenon of selective reflection was used in commercial applications before liquid crystals were used in display applications. The pitch p of the helical structure is of the order of the wavelengths of visible light. A beam of white light coming in the direction of the helical axis splits into two polarized beams: one beam with a right circular polarization and the other with a left circular polarization. Here, the light having its rotation of polarization in the same direction as the helical rotation is selectively reflected at the end surface; the light with the other rotation of polarization, transmits. Using the Bragg relation, we see that a film of the liquid crystal will

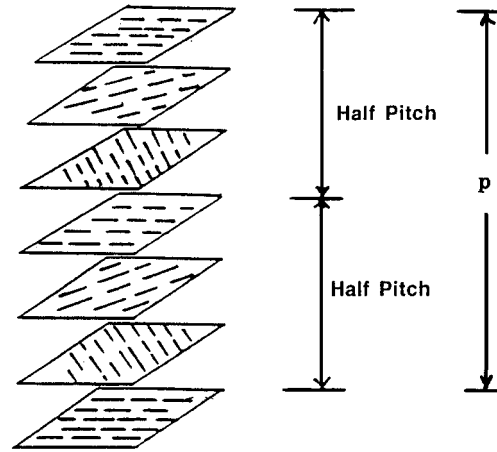

Fig. 7. Cholesteric liquid crystal [3].

reflect the light and appear colored. The wavelength λ of the reflected light is

$$\lambda = p \left(2 \left(n_{\text{parallel}}^2 + n_{\text{perpendicular}}^2 \right) \right)^{1/2} \quad (6)$$

where n_{parallel} and $n_{\text{perpendicular}}$ are refractive indices in parallel and rectangular respectively to the long axis of the molecule [4]. The pitch p is subject to change with temperature and so the color of the film also changes with temperature. Generally speaking, as temperature increases, p becomes small and the reflected light moves to a shorter wavelength. Ferguson and his group at Westinghouse Research Laboratories fabricated flexible films and tapes that can be applied to the surface of objects to record temperatures. They applied the film to the skin of a human body to locate veins and arteries and to electronic circuit boards to locate trouble spots [6].

One product incorporating cholesteric liquid crystals available in the market place is a stress testing card. This is a credit-card-sized plastic card on which cholesteric liquid crystals are painted. Ordinarily, the card is black. One presses the card between thumb and index finger for 15 seconds. If the color changes to blue, the card indicates that finger temperature is high and the subject is relaxed. If the color changes to red, the subject's finger temperature is low, indicating tension.

Cholesteric liquid crystals are also used as additives in a TN and super TN (STN) LCDs, which will be discussed later.

III. DYNAMIC-SCATTERING MODE—AMERICA'S AGILITY IN TAKING A NEW IDEA AND DEMONSTRATING ITS FEASIBILITY

The development of LCDs started at RCA Laboratories in Princeton, NJ.

A. Williams Domain

In 1962, Richard Williams of RCA found that liquid crystals had some interesting electrooptic characteristics [7], [8]. He sandwiched a liquid crystal p-azoxyanisole (PAA), a negative nematic type liquid crystal, between two glass plates. The range over which it exhibited the liquid-crystal phase was from 117 °C to 134 °C. The liquid-crystal specimen between the glass plates was heated to a liquid-crystal tempera-

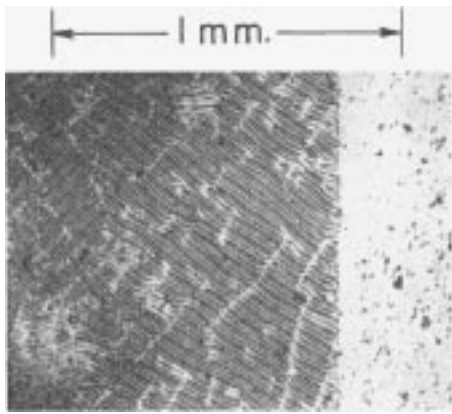

Fig. 8. Williams domains in p-azoxyanisole liquid crystal. The vertical line about 1/3 of the way from the right border is the edge of the strip of transparent conductive coating. To the right of this, there is no field in the liquid. To the left, there is a 1-kHz ac field of 2500 V/cm directed perpendicular to the plane of the page. Specimen thickness is about 50 μm and temperature is 125 $^{\circ}\text{C}$ [8].

ture by supporting one of the glass plates on a heating stand. Each plate had a transparent tin oxide conductive coating on its inner faces and appropriate leads for making contact to an external circuit. Spacing between the plates was about 50 μm . He used a strip of conducting coating, which was less than the width of the glass plate. This allowed simultaneous observation of adjacent regions of the same specimen with and without an electric field.

By applying an electric field perpendicular to the surface of the glass, he observed the appearance of a regular pattern in the area where the electric field was applied. As shown in Fig. 8, the pattern consisted of an array of long parallel regions, which he referred to as “domains.” Either alternating-current (ac) or direct-current (dc) voltage produced the domains. An ac voltage of 1 kHz was used where possible because the ac voltage produced a somewhat more stable pattern and electrochemical deterioration of the liquid was minimized. The electrical resistivity of the liquid crystals was approximately $10^9 \Omega \cdot \text{cm}$. This indicated that any ionic impurities that might be present were there only in small amounts. He reported that none of the effects could be due to electrochemical deposition of the material, since the current flow was much too small to produce the effects in the required time. An ac signal of around 12.5 V was required, which means an electric field of about 2500 V/cm. He concluded that the domains were due to ordering in the liquid of a kind that had not previously been recognized. He demonstrated the feasibility of liquid crystals as electrooptical elements for display devices. This was a forerunner of the LCD. The phenomenon he discovered is now referred to as the “Williams domain.”

B. Guest-Host Mode

The development of the first LCD is well described by Heilmeier [9]. Some of the following is taken verbatim from his article.

In 1961, Heilmeier had finished his written and oral examination for the Ph.D. degree at Princeton University under

RCA Laboratories’ sponsorship. In those days, young scientists and engineers were in great demand. RCA Laboratories recruited top-notch talent and financed their graduate education while enabling them to work part time and summers at the laboratory on meaningful research projects. Heilmeier first worked for over two years in the then emerging field of solid-state microwave devices. However, as an ambitious young scientist, he was wondering whether to stay in the rather established solid-state microwave field or enter the more fascinating and risky field of organic semiconductors.

At around the same time, Heilmeier was attracted to the experiments on the Williams domain. He selected a strong dye whose molecules were cigar shaped. The dye was pleochroic; it absorbs light when the direction of polarization of linearly polarized light is in the direction of its long axis and transmits light when the direction of polarization is not in the direction of the long axis. He doped the nematic liquid crystal, butoxy benzoic acid (p-type 147 $^{\circ}\text{C}$ –161 $^{\circ}\text{C}$), with the dye. The cigar-shaped dye molecules aligned parallel with the liquid crystals. Here, the dye is called the guest and the liquid crystals are called the host. The mixture was sandwiched between two glass slides coated with transparent tin oxide electrodes and placed under a microscope with a hot stage. A dc voltage of several volts was applied and they watched the cell change color from red to colorless as a function of the applied field [10]. As seen in Fig. 9, when no voltage was applied, the guest and host molecules were aligned at right angles with the direction of incident light and therefore absorbed light and appeared colored. As the electric field was applied, the guest dye molecules were reoriented along with the host nematic liquid-crystal molecules. They were now aligned parallel to the direction of incident light and the mixture became transparent. It was found almost immediately that the effect was more dramatic with a polarizer in place. The device was drawing a very small electric current, less than a microwatt of power per square centimeter and they were switching color with voltages substantially smaller than those of CRTs—less than 10 V for liquid-crystal dye mixture versus more than 1000 V for CRTs. This was in the fall of 1964. Heilmeier thought a wall-sized flat-panel color TV was just around the corner. As we will see, that realization took another quarter century.

When Heilmeier demonstrated this effect within the laboratories, the people there became excited. Vladimir Zworin, known to many in the field as the father of television, heard about the experiment and summoned Heilmeier to his office to find out why people in the laboratories were so excited. Heilmeier explained how he had “stumbled” onto the guest-host color switching effect. He never forgot Zworin’s reflective reply: “Stumbled perhaps, but to stumble, one must be moving.” Later, in 1982, the guest-host mode combined with an AM drive would be used in a wristwatch television.

C. Dynamic-Scattering Mode

There were obvious problems with the guest-host effect. The dyes and their liquid-crystal hosts were not stable over long periods of time in applied fields, the effect was sensitive to surface orientation effects, and it required heating

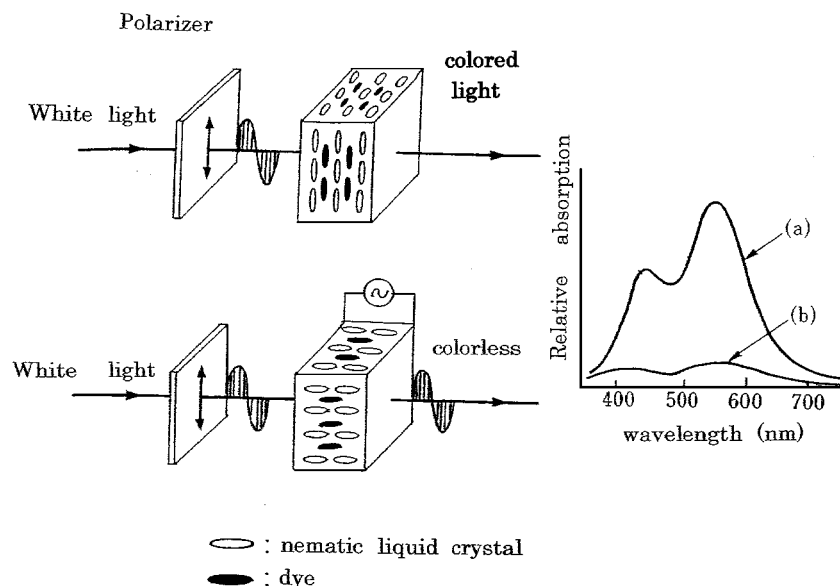

Fig. 9. Guest-host cell [4].

to maintain the host in its nematic phase. RCA scientists tackled these problems on all fronts. In late 1964, they observed an interesting effect in certain classes of nematic liquid crystals—those with n-type [11]. The materials that yielded the best performance were members of a class of organic compounds known as Schiff's bases. They found the compound anisylidene para-aminophenylacetate (APAPA) to be of particular interest. Its nematic range was from 83 °C to 100 °C. In an applied field, these materials exhibited a marked turbulence that turned them from transparent to milky white. The milk-white appearance required no polarizer to observe; it was purely a light scattering effect. Heilmeyer discovered a very efficient way to electronically control the reflection of light. The rise time of 1–5 ms and decay times of less than 30 ms together with dc operating voltages in the 10–100-V range made the new mode attractive for such applications as alphanumeric indicators. Reflective contrast ratios of better than 15 to 1 with efficiencies of 45% of the standard white were demonstrated. He named it DSM. It was the first demonstration that those obscure materials called liquid crystals could be made into something useful. The LCD was born.

The dynamic-scattering process occurs in the following manner [12]–[14] (see Fig. 10).

- 1) Nematic liquid crystals are aligned perpendicular to the parallel plates.
- 2) Applying an external field perpendicular to the plates, liquid crystals are aligned in a direction parallel to the plates because of the n-type.
- 3) In nematic liquid crystals, the electrical conductivity in the direction along the long axis is larger than in the short-axis directions, which causes charge buildup.
- 4) The induced field and external field give rise to a shear torque on the molecules, which causes a circular motion of the molecules. This state may correspond to the Williams domain.

- 5) By further increasing the external field, the molecules go into a mechanically unstable state or turbulence. The molecules now randomly scatter the light incident on the molecules and appear milky white.

The process is sometimes called an electrohydrodynamic instability. In Europe, it is referred to as the Carr–Helfrich effect.

It was clear that for dynamic scattering to have a major impact, RCA was going to need room-temperature nematic materials. Joel Goldmacher, Joe Castellano, and Luke Barton went to work on the problem and in a relatively short period of time, developed a mixture of Schiff's base materials that were nematic at room temperatures [15]. With these materials in hand, Heilmeyer, Louis Zanoni, and other RCA engineers designed and fabricated prototype devices based on DSM. Alphanumeric displays, windows with electronically controlled transparency, static pictorial displays (see Fig. 11), an all electronic clock with a liquid-crystal readout, and liquid-crystal cockpit displays were fabricated. These crude prototypes excited everyone at RCA.

On May 28, 1968, RCA held a press conference at its headquarters at Rockefeller Plaza, New York. They proudly announced the discovery of a totally new type of electronic display [16]. The display was dramatically different from traditional CRTs. It was lightweight, consumed little electrical power, and was very thin. The press conference drew the attention of scientific and industrial communities all over the world. This announcement initiated the development of digital watches in the U.S., Japan, and Germany and the work on pocket calculators in Japan. At the same time, it led to further scientific work in Germany, Switzerland, and the U.K.—particularly for the synthesis of new liquid-crystal materials suitable for use in display applications.

D. Aftermath

Naturally, Heilmeyer wanted to see his invention evolve into RCA products. He went to company headquarters

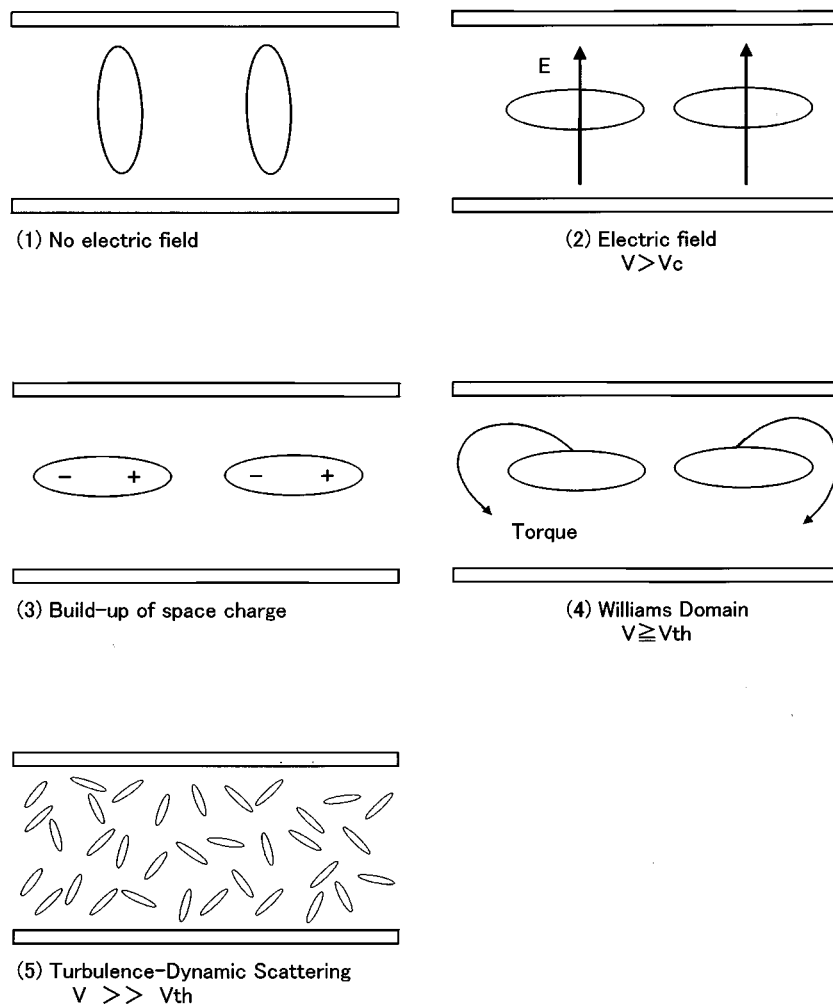

Fig. 10. Mechanism of DSM. (Courtesy of T. Wada.)



Fig. 11. Heilmeier demonstrates a static DSM display [16].

and convinced RCA to go into the business of LCDs. The task was given to the Solid-State Division in Sommerville, NJ, which was responsible for the design and production of semiconductor devices. However, Heilmeier quickly received negative responses from the naysayers. Liquid crystals were not “silicon.” They were “dirty” by semiconductor standards. They were liquids. They were too easily duplicated. They were said to be too difficult to make. These

were some of the many reasons the product division gave for its failure to commercialize LCDs.

At the time, RCA owned a substantial amount of business in CRTs. Top management eventually rejected the idea of LCDs because they represented a threat to their existing CRT business.¹ According to Heilmeier [17]: “The people who were asked to commercialize (the technology) saw it as a distraction to their main electronic focus.” In 1970, he gave up, accepting an appointment as a White House Fellow working in the Department of Defense as a Special Assistant to the Secretary of Defense. The term of the fellowship was for one year and he was supposed to come back to the original position after the assignment was completed, but it was obvious to everyone that he would never come back to Princeton. Later, he became the president of Bell Communication Research Inc., the research arm of the Baby Bells. In 1987, RCA Laboratories merged with Stanford Research Institute, Menlo Park, CA.

Richard Williams, when recalling the early days, has said, “If it had continued the work, RCA would have never achieved a commercial success.” It had to await the devel-

¹Section VI describes that U.S. control of the CRT business was precisely why the U.K. went into LCD research and succeeded in formulating commercially usable liquid crystals.

opment of liquid-crystal materials and amorphous silicon (a-Si) technologies, both of which were yet to come from Europe. Those developments altogether have taken a quarter of a century. Heilmeier would have not achieved success had he stayed with liquid-crystal technologies.

IV. THE POCKET CALCULATOR—JAPAN'S SPEED IN COMMERCIALIZATION

In late 1968, a team from NHK (Japan Broadcasting Corporation) visited Heilmeier at Princeton. They had been making a documentary called "Firms of the world: Modern alchemy." The documentary aired in January 1969. At that time, RCA was a giant in the electronics industry and had led the industry with innovations such as audio records, radio, and color television; all had been inspired and their developments had been guided by RCA's spiritual leader, David Sarnoff. A liquid-crystal section of the documentary was rerun in 1983. At its May 1968 press conference, RCA did not want to disclose the name of the liquid crystal they had used. Now, years later, we recognize that RCA was very generous to NHK. The videotape of the 1983 run shows Heilmeier demonstrating the alphanumeric display and the window with electronically controlled transparency. He drew a diagram of a liquid crystal on a black board that appeared to be a Schiff's base; a mixture of its homologues exhibited nematic phase at room temperatures [15]. The diagram indicated that the applied voltage was 6–60 V dc and Zanoni even demonstrated how to fabricate a display by sandwiching liquid crystals between two glass plates. It is noticeable, however, that all of the chemical bottles on the shelves had been rotated so the viewers could not read the labels. This had been the condition under which NHK was able to enter the laboratory.

Tomio Wada of Central Research Laboratory of the Sharp Corporation, then called Hayakawa Electric Company, immediately became interested in RCA's May 1968 announcement. He was looking for an electronic display suitable for a yet-to-be-realized pocket calculator. A display made of liquid crystal seemed ideal because it was thin and lightweight and it would consume very little power compared with any other proposed flat display. In addition, it would match well electrically with the complementary metal-oxide-semiconductor (CMOS) circuit, which was considered the computing device of choice for use in pocket calculators. Wada told his management to investigate the developments at RCA. Tadashi Sasaki, in charge of the overall industrial equipment business, visited RCA at the end of 1968. He visited Roy Pollack at the RCA headquarters in New York and Bernard Vonderschmidt at the Solid-State Division in Sommerville, NJ, where he observed the demonstration of DSM LCDs and thought the devices had potential. Sasaki tried to persuade Vonderschmidt to go into production of the LCDs for use in a pocket calculator. He even indicated that he was willing to pay as much as RCA needed for the development. However, RCA was only interested in making the displays for use in watches for Timex Corporation and was not interested in the calculator

display. They thought the response time of the display was too slow: it was suitable for clock displays, but not fast enough for calculator displays. Sasaki came back to Japan thinking that the only choice was for Sharp itself to develop the calculator display. When he reported the results of the meeting, he quickly faced resistance. If the inventor at RCA could not make the device, then how could an upstart like Sharp succeed? Wada argued that unlike light-emitting diodes (LEDs) or electroluminescent displays, the LCD would not emit light by itself and would thus be easier on the human eye. He insisted that Sharp start work on liquid crystals. Sasaki agreed, thinking this might change the world of electronic displays. In 1970, Sharp launched its research on LCDs.

Though educated as a chemical engineer, Wada had never heard of liquid crystals before. No technology existed on liquid crystals within Sharp and almost no literature was available in its library. Until the late 1960s, only a few compounds—most of them exhibiting liquid crystal phase at temperatures higher than the room temperature such as PAA and APAPA—were used as standard materials for scientific experiments. Wada purchased every possible liquid crystal available on the market. Some even cost as much as 12 000 yen per gram. He had to obtain a special purchasing authorization because of their high price. The liquid crystals were dirty by semiconductor standards and very unstable. There were still many problems ahead of him to be solved.

In 1964, Sharp's Industrial Equipment Group had produced the first desktop calculator made only of transistors and diodes. It measured 42-cm wide \times 44-cm deep \times 25-cm high and weighed 25 kg; it was priced at 535 000 yen. Sharp then worked to miniaturize the calculator. The key was to use metal-oxide-semiconductor (MOS) ICs (ICs) instead of discrete transistors and diodes. Sasaki negotiated and persuaded Rockwell Corporation, a hardcore defense electronics company, to go into the consumer electronics business. Rockwell fabricated the MOS calculator circuits and supplied them to Sharp. In 1969, with the use of such ICs, they were able to reduce the size of the calculator to 13.5 cm \times 24.7 cm \times 7.2 cm. Its weight came down to 1.4 kg. They offered it at a price of 99 800 yen. Immediately, competitors jumped onto the bandwagon. This event marked the start of a cut-throat price war that the Japanese called "dentaku sensou (calculator war)." Eventually, Casio Corporation would offer a calculator at a price as low as 4800 yen.

The Industry Equipment Group was concerned. They needed a technology dramatically different from and lower in manufacturing cost than the existing technology. Isamu Washizuka thought the key was to be found in the display. The calculators at that time used vacuum fluorescent display tubes or Nixie tubes as display elements. This caused the calculator to be bulky, heavy, expensive, and power-consuming. He thought the only way to miniaturize the displays was to use a passive nonself-emitting display and ordered his team to find such a device. Then, he heard about the research on LCDs. He asked Wada if the liquid crystal could be used for pocket calculator displays. Wada's reply was that a liquid-crystal technology would be most suitable in a

pocket calculator application. When Washizuka announced to his group that he was going to use liquid crystals for the display, they were thrown into confusion. Though they understood that the liquid-crystal technology would be inherently ideal for use in pocket calculators, they could not rely on a material that had not been proven in mass production. Yes, it would be risky, but the returns would be high. Washizuka declared: "We'll try." This was the only choice he had at the time. He especially liked the fact that liquid crystals would be a good match with CMOS circuits. Just at that time, he learned that it had become possible to place large-scale integrated circuits (LSIs) on a glass substrate. If Wada succeeded in the development of LCDs, it would be possible to place both the LSIs and the LCD on a common glass substrate. This would substantially reduce the assembly costs.

In order to accomplish the development of the pocket calculator, Sharp created a special project team. The project team consisted of managers, engineers and researchers drawn from various groups and divisions. The project would take three to five years if ordinary development procedures were used, but instead, by assembling engineers and scientists from related but different disciplines into a single team and giving them a common objective, the special project team was designed to complete the commercialization in one to one-and-a-half years. The members of the team wore gold color personnel badges, the same as the one worn by the president. *Fortune Magazine* later interviewed the members of the team and named the project a "gold badge" project. The project was code-named S734; S stood for secret and 734 stood for completion by 1973 in the fourth month of the year. They were given only 12 months for commercialization. The project team collected scientists from the Central Research Laboratory to work on liquid crystals, engineers including Mitsuo Ishii from the IC Division to work on thick film hybrid ICs and engineers from the Industry Equipment Group to work on system design. It consisted of 20 members.

The key was to find a liquid crystal that would operate at room temperature and exhibit a high contrast display. Wada and his team mixed over 3000 kinds of liquid crystals and synthesized over 500 mixtures. The objective was to simulate the liquid-crystal mixture that Heilmeyer had used in the RCA press release. The work was time consuming and tedious. They finally arrived at a mixture of Schiff's bases, consisting of n-(4-methoxybenzyliden)-4-n-butylaniline (MBBA), n-(4-ethoxybenzyliden)-4-n-butylaniline (EBBA), and n-(4-butoxybenzyliden)-4-n-butylaniline (BBBA) (see Fig. 12) [18]. It was of nematic type and exhibited nematic phase in the temperature range from -20 to 63 °C. It had an n-type, a high Δn , and a low viscosity. In the DSM, it worked in the temperature range from 0 to 40 °C. Wada's team found that the addition of a small amount of impurity was required to induce ionic currents and thus to aide the formation of space charges. The quantity of impurity was determined by taking into account his findings: increasing the impurity reduced the lowest operating temperature, the impurity made a current distribution uniform leading to a

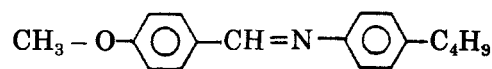

MBBA

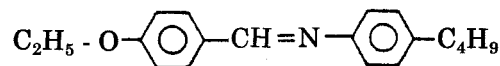

EBBA

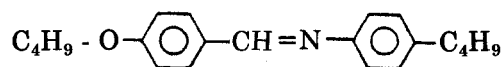

BBBA

Fig. 12. MBBA and its homologues used in the pocket calculator.

uniform display, and further increasing the impurity raised the ionic current and reduced the life of the display. He found that tetra butyl ammonium salt $\text{XCOO} - \text{N}^+(\text{C}_4\text{H}_9)_4$ was chemically stable and useful for the improvement of electrooptical properties. Wada found that as he purified the liquid crystals to a higher degree, he needed to add more impurities to create ionic currents.

In addition to the investigation of the material itself, the team needed to investigate which driving method, ac or dc, was superior. The dc field caused the generation of bubbles in the mixture and degraded the material rather quickly. The ac field caused a difficulty in operation at low temperatures and required a complicated electronic circuit. They eventually settled on the ac field. Another problem was the requirement for a transparent yet electrically conductive plate. Wada went to Shunsuke Kobayashi of Tokyo University of Agriculture and Technology and found that the Ministry of International Trade and Industry (MITI) Laboratory in Osaka had been working on indium tin oxide (ITO). Sharp sent an engineer to the laboratory to learn the ITO technique. Back at Sharp, he could replicate the ITO film with the use of electron beams. Then, they were told that the research at the MITI Laboratory was being done to aide small size companies. To use the results of the research, large companies such as Sharp had to receive special permission. Wada persuaded MITI to grant permission based on the prospect that LCDs would become the key device for the future of Japanese industries and that the mass production of LCDs would require an infrastructure of many small companies, which would benefit from the creation of a new liquid-crystal industry. They also

had to solve a host of other problems such as developing the photolithography technology for forming the required conductive pattern on a glass substrate, holding the two glass plates a few micrometers apart and at a perfectly constant distance, and prealigning liquid-crystal molecules in one direction.

The other problem was computing and driving circuits. Everybody agreed that CMOS was the right solution. Its electrical power consumption is low compared with bipolar and MOS circuits, thus, it is ideal for use with batteries, where the electrical energy supply is limited. The operating voltage for CMOS circuits was a good match with LCDs. For the idea of CMOS circuits, we go back to Paul Weimer of RCA Laboratories in 1962 [19].² RCA and Fairchild were involved in the commercialization of the CMOS circuits, but only interested in military applications. Sharp needed to find a company that would supply them with the CMOS circuits for use in “consumer-use” electronic calculators.

Just at that time, Yasoji Suzuki of the Toshiba Corporation was working on such CMOS circuits. He had developed a “clocked” CMOS circuit [20]. When a clock pulse was supplied to the clocked CMOS inverter, the circuit acted as a conventional inverter. When no clock pulse was supplied, the circuit stored a charge on the output capacitors. Thus the overall power dissipated by the circuit was reduced substantially. The power consumption for conventional p-MOS circuits designed for a calculator was from 400 to 500 mW; the power consumption was reduced to less than 2 mW with the use of clocked CMOS circuits. He constructed a mockup and demonstrated it to Sharp engineers, who were sufficiently intrigued to ask to borrow the mockup for test purposes. Eventually, he supplied the clocked CMOS LSIs to the Sharp Corporation. Just before April 1973, Sharp completed the development of the pocket calculator and constructed a production line for manufacturing the new product.

On May 15, 1973, Sharp announced [21] and subsequently introduced the Elsi Mate EL-805 pocket calculator, comprised of an LCD and five ICs placed on a common glass substrate (see Fig. 13) [22]. The calculator was revolutionary because it was only 2.1-cm thick, a reduction by a factor of 12 from other electronic calculators available at that time. It weighed 200 g, a reduction by a factor of 125. It could be slipped into a shirt pocket. Its power consumption was only one 1/9000 of existing calculators, so it could be operated for 100 h with a single AA-size dry battery. Wada recalls that, on the day before they shipped the first pocket calculator, Atsushi Asada, then General Manager of the Industrial Equipment Division, cornered him and asked whether the pocket calculator was really reliable enough to be placed in the market place. Wada knew that the MBBA mixture was unstable and had, thus, sealed the cell extremely tightly. He did not have any choice other than saying, “It should be OK.” The calculator was an immediate hit in the market place and

²When he saw the pocket calculator at Sharp’s museum, James Tietjen, then the President of David Sarnoff Research Center, formerly RCA Laboratories, grumbled that two technologies both key to the realization of pocket calculators—LCDs and CMOS circuits—had started at RCA Laboratories and ended up at Sharp Corporation.



Fig. 13. The first liquid-crystal pocket calculator, which used DSM. Courtesy of Sharp Corporation.

was the first commercially successful product to use an LCD. One such calculator, now 28 years old, has been found still operational.

The ultimate goal for developing LCDs was to accomplish a wall-hanging television. When he had invented the LCD, Heilmeyer had thought that a wall-hanging television would be just around the corner. When I asked Wada if he had the same thought when he succeeded in the pocket-calculator display, his reflection was that the time response of DSM was very slow. Television needed a fast response and multiplexing. He did not think making a television using DSM technology would be possible for a long time. To create a television display, one had to have yet-to-be-discovered modes of operation, such as TN mode and AM driving and yet-to-be-synthesized materials such as phenyl cyclohexanes. Wada never imagined that LCDs would create an entire industry.

V. TWISTED-NEMATIC MODE—NEW MODE OF OPERATION DISCOVERED ALMOST SIMULTANEOUSLY IN SWITZERLAND AND AMERICA

The pocket calculator that Sharp introduced in 1973 was a great success; calculators, which had been targeted at the business market, were now being used in classrooms and homes. The pocket calculator was even used in unforeseen ways. One day, a Sharp’s Sales Division representative received a telephone call from the Tohoku district in northern Japan. The caller said that a calculator had stopped working. It was discovered that the customer had been using it in an outdoor lumberyard in subzero temperatures. Wada knew that the pocket calculator did not work at subzero temperatures; it was operational only in the range of 0–40 °C. The designers had never expected it would be used outdoors, but because the calculator was portable, its area of use had changed. The Sales Division now demanded a calculator that would work both indoors and outdoors. Asada ordered manufacturing of the calculator to be stopped. The engineers objected, saying that the use at subzero temperatures was limited to winter times in northern areas and in most places

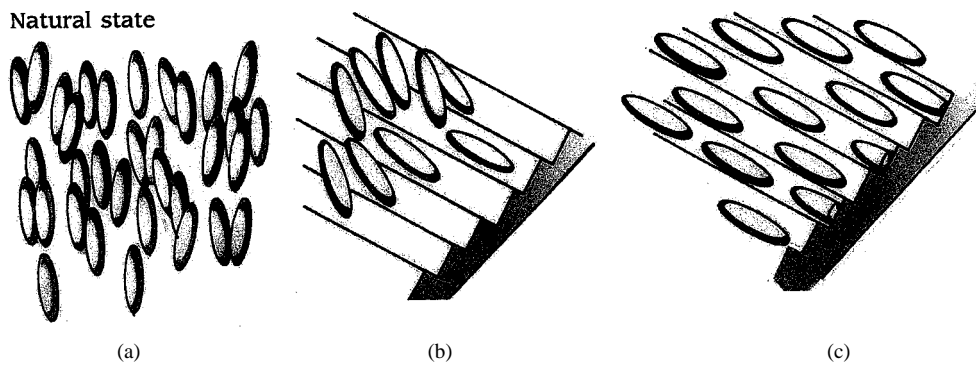

Fig. 14. Nematic molecules' parallel alignment along grooves. (a) In free space, molecules are aligned in a loosely ordered fashion with their long axes in parallel. (b) When flowing on a finely grooved surface. (c) Molecules are lined up parallel along the grooves.

in Japan, customers could make full use of the existing product. Besides, the calculator was selling like hot cakes. Why not concentrate on selling what they had in their hands? Nevertheless, Asada insisted they develop a new calculator that would work not only at subzero temperatures, but be thinner than the first model and even be capable of displaying complicated Japanese Kanji characters. After that, the engineers started referring to Asada as "the devil."

When the Sharp engineers started the development of the next generation pocket calculator, negative liquid crystals that worked at subzero temperatures in the DSM did not exist. Besides, the Schiff's-base liquid crystals were easily hydrolyzed, which caused them to deteriorate. Though the drain on the batteries for the pocket calculator using the DSM was much slower than that for Nixie tube calculators, the ionic currents required for the operation of the DSM caused the batteries to drain faster than the very small currents of the TN mode. Since the time response of the MBBA in the DSM at near-zero temperature was very slow, the numerals on the screen appeared and disappeared very slowly. Some called it an "Obake" or a ghost because ghosts in Japan are believed to appear and disappear in slow motion. In order to create a reliable calculator that would work at subzero temperatures and exhibit a fast response, the engineers had to wait for the developments taking place on the other side of the globe: the discovery of TN mode and the synthesis of new p-type liquid crystals which this field-effect mode required: "cyanobiphenyls" (see Section VI).

A. Discovery of Twisted-Nematic Mode by Schadt and Helfrich

Wolfgang Helfrich joined RCA Laboratories, Princeton, NJ, in 1966, and then took a leave of absence in Germany for one year. He came back to RCA in October 1967 and was assigned to Heilmeyer's emerging Liquid Crystal Group. He found much data had been accumulated on liquid crystals, but no physical explanation had been offered for the data. He started modeling LCDs to help understand the physics of the DSM. He reasoned that the Williams domain was current-induced shear torque and that the DSM was perturbation caused by further driving the Williams domain [13]. In the course of the analyses, an idea came to his mind for a new method of driving liquid crystals—to TN liquid

crystals of p-type. Helfrich recalls that when, in the summer of 1969, he went up to Heilmeyer and explained the new idea, Heilmeyer showed little interest because the new mode required two polarizers. At the time, liquid-crystal work was winding down at RCA. Frustrated by their interactions with the product division, the engineers and chemists in the liquid-crystal team started to drift away. Zanoni went to Optel, where he continued to develop liquid-crystal technology and displays. Later he was joined by Goldmacher who had made an interim stop at St. Regis Paper. Heilmeyer left in 1970 to become a White House Fellow. Castellano, Chan Oh, and Mike McCaffrey also departed to work on LCDs elsewhere.

Helfrich also left RCA and in early October 1970 joined Hoffmann-La Roche in Basel, Switzerland, to work with Martin Schadt. Helfrich suggested that Schadt, rather than using the DSM, try a totally new mechanism of operation. Schadt agreed and devised an experimental setup. In a few weeks, they found a new workable mechanism: TN mode. On December 4, 1970, they filed a patent with the Patent Office in Switzerland [23]. A mere four days later, they submitted the now historic paper "Voltage-dependent optical activity of a twisted nematic liquid crystal" to *Applied Physics Letters* [24]. They said that, up to that point, three electrooptical effects had been known: 1) domain formation; 2) dynamic scattering; and 3) guest-host interaction. They reported the discovery of a fourth electrooptical effect. It involved realignment of liquid-crystal molecules by dielectric torques. The new effect required the orientation pattern to be twisted in the fieldless state.

As shown in Fig. 14(a), nematic liquid crystals, typically 30 Å in length, in natural states are arranged in a loosely ordered fashion with their long axes in parallel arrangement. If grooves are carved on the surface as shown in Fig. 14(b) and (c), the liquid crystals lie on the surface and line up in parallel with the direction of the grooves [25], [26]. Let us consider the case where the liquid crystals are sandwiched between an upper plate and a lower plate and the plates are grooved in directions "a" and "b," which are orthogonal to each other as shown in Fig. 15. The molecules along the upper plate align in direction "a" and those along the lower plate in direction "b." This forces the liquid crystals into a 90° helical twist [27]. An LCD may be structured as sketched in

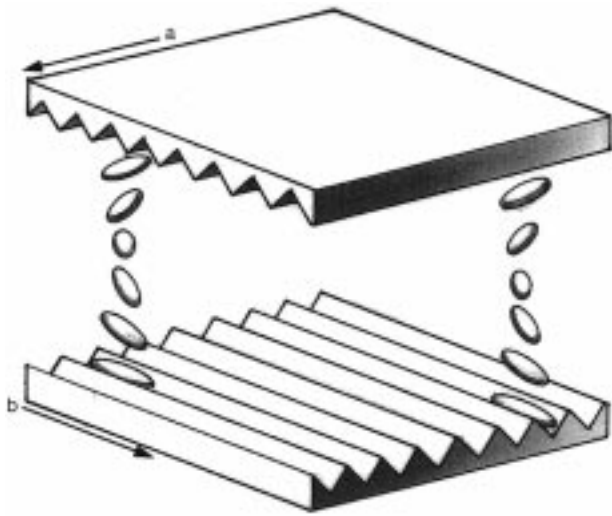

Fig. 15. Molecules along the upper plate in direction “a” and those along the lower plate in direction “b,” thus, forcing the liquid crystals into a 90° helical twist.

Fig. 16. The distance between the plates is typically 10 μm ; thus, the resultant pitch of the twist is 40 μm . The pitch is much larger than the wavelengths of light coming from the top. Two polarizing filters are placed on the outer surfaces of the two plates. The direction of the polarization of the filters is aligned in parallel with the groove directions. Only the light with the polarization in axis “a” passes through the polarization filter at the top. By solving a dispersion equation on the propagation of electromagnetic waves, the direction of polarization of the light entering the liquid-crystal region may expect to rotate by 90° along the helix arrangement of the liquid-crystal molecules [28]–[30]. Therefore, the linearly polarized light passes through the lower filter [see, e.g., Fig. 16(a)]. Now consider the nematic liquid crystals having a p-type. When a voltage is applied across the two plates, the liquid-crystal molecules align along the direction of the electric field and straighten out of their helix pattern and, thus, no longer rotate the direction of the polarization of the light passing through [27] [see, e.g., Fig. 16(b)]. The light is blocked at the bottom polarizing filter and the screen appears black. In other words, the voltage acts as a trigger causing the liquid crystals to function like the shutter of a camera.

The phenomenon illustrated in Fig. 16 is referred to as the “normal white” case of TN mode. If the bottom polarizer is rotated by 90° and, thus, is in parallel with the top polarizer, the light is blocked when no voltage is applied, and the light passes when a voltage is applied; this phenomenon is referred to as the “normal black” case of TN mode.

They chose as their liquid-crystal material n(4'-ethoxybenzylidene) 4-amino-benzonitrile (PEBAB), which is nematic between 106 °C–128 °C and of strong p-type with $\epsilon_{\text{parallel}} \sim 21$ and $\epsilon_{\text{perpendicular}} \sim 7$ [31]. For room-temperature operation, they used a mixture comprised of alkoxy- and acyloxy-cyano-Schiff's bases [32], which were nematic between 20 °C–94 °C.

The grooves on the inner walls of the glass plates were obtained by the well-known method of rubbing the electrodes

with a cotton swab [25], [26]. The angle of rotation as a function of voltage for the alkoxy-cyano-Schiff's base mixture is shown in Fig. 17 for a 10- μm -thick sample. Also plotted for the same driving frequency of 1 kHz is the transmission versus voltage. The brightening effect has a threshold of root mean square (rms) 3 V and is roughly 90% complete at rms 6 V. The effect was operational for both dc and ac voltage. With the ac operation, the appearance of the cell was more homogeneous and the threshold lower than those with the dc operation. The effect showed no hysteresis and the cell returned to its initial state when the voltage was turned off.

A formula for the threshold voltage V_c is given by (5). It is seen that the threshold voltage can be made very small if $k_{33} - 2k_{22} < 0$. The reduction of threshold voltage was not surprising, since realignment releases the elastic energy associated with the initial twist. This may explain why they observed a threshold voltage smaller than the 5–8 V common in the previous DSM. Theoretically, the new effect has a thickness-independent threshold voltage.

It was immediately felt that the requirement of installation of two polarizers and the surface alignment of the liquid crystals complicated the structure. However, since no ionic current was required to generate an optical signal with the TN configuration, displays based on the TN mode consumed an extremely low electrical power, just a few microwatts per square centimeter. The contrast between off and on state was higher than that of DSM.

Because of these favorable properties, their article had a great impact in the community of liquid-crystal scientists. It induced Wada to switch his research emphasis from DSM to TN mode. And when the U.K. launched research on synthesizing room-temperature liquid crystals (see Section VI), they chose the TN mode. The discovery of TN mode induced Suwa Seiko of Japan, which had been working on the DSM in developing digital watches, to switch to the TN mode (see Section VII). An STN mode was developed as an extension of the TN mode (see Section VIII). AM driving uses the TN mode in its operation mechanism (see Section IX). Currently, the TN mode and its derivatives are implemented in virtually all LCDs manufactured throughout the world. It may not be an overstatement to say that Schadt and Helfich's paper [24] is the basis of the LCD industry today.

The team of physicists and chemists at Hoffmann–La Roche worked on better understanding the behavior of highly ordered molecules and to find the correlation between molecular structures and display performance. They developed and commercialized two positive high $\Delta\epsilon$ TN mixtures: one comprised of alkyl-cyano-Schiff's bases [33] and the other of cyano esters, which were used in many laboratories that started experimenting with the TN mode. In 1972, a change in research management at Hoffmann–La Roche forced the small group working on the liquid crystals to stop the project. In 1973, a British team synthesized cyanobiphenyls, which worked in the TN mode at subzero temperatures. Suddenly, Seiko of Japan approached Hoffmann–La Roche and asked to purchase the patent on the TN mode. Recognizing the importance of the patent, the management at Hoffmann–La Roche asked

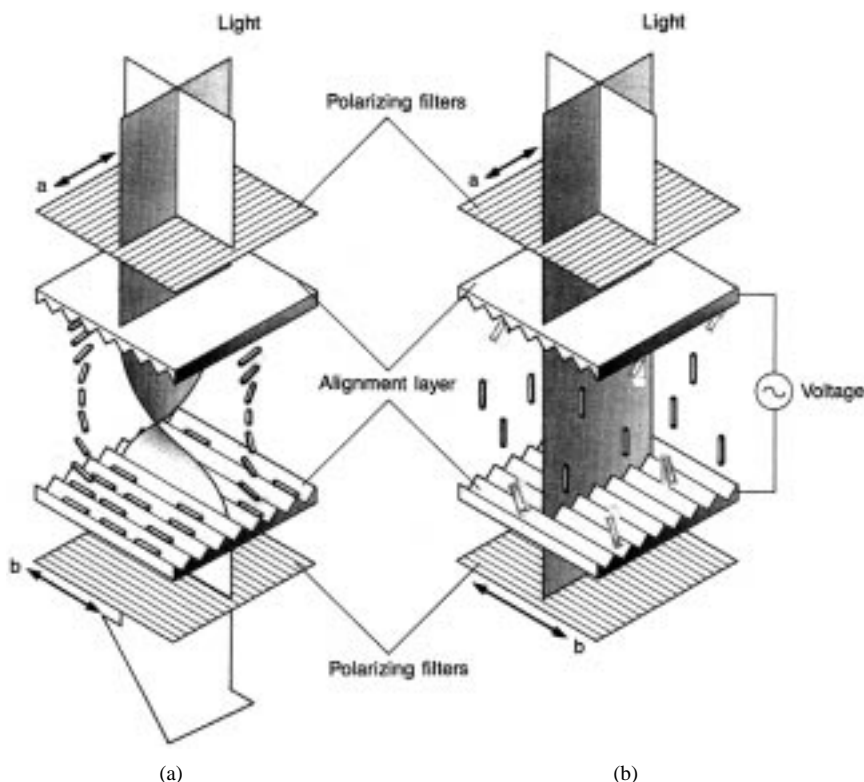

Fig. 16. TN cell (normally white case). (a) When two polarizers are arranged in parallel with the directors, light entering through the top polarizer is linearly polarized, then redirects the polarization by 90° along the helix arrangement of the nematic molecules, so light passes through the lower polarizer. (b) When voltage is applied, the nematic molecules straighten out of their helix pattern and no longer redirects the polarization, so light cannot pass through the lower polarizer.

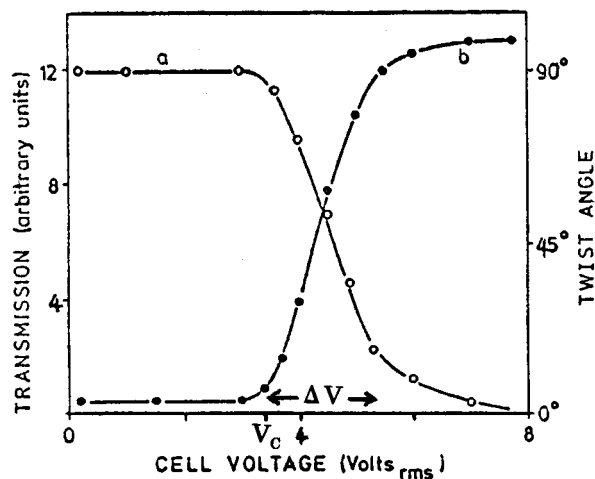

Fig. 17. Rotation angle of linearly polarized light versus voltage for the cyano-Schiff's base mixture at room temperature (at 1 kHz) shown by "a." Transmission versus voltage for normally black case shown by "b" [24].

Schadt to reassemble the research team, make a proposal to commercialize Hoffmann-La Roche liquid crystals, and license the TN patent to the emerging liquid-crystal device industry.

Did Helfrich (Fig. 18) conceive the TN mode when he was with RCA? To resolve this historical question, I asked Alfred Ipri to search the writings of Helfrich in the library of David

Sarnoff Research Center (formerly RCA Laboratories) and later did the same thing with Alex Magoun, the Sarnoff curator. Helfrich had left 15 reports including the reference [13] in Sarnoff. None of them indicated the TN field effect. He did not leave any laboratory notebook on which researchers were supposed to record any ideas and inventions.

When I met Helfrich of the Institute für Theoretische Physik of Freie University in 1993, he confirmed that he had indeed conceived the idea of TN mode in around 1969 while he had been with RCA. He said that he had never used the laboratory notebook and that he was not supposed to invent anything, but to help understand physics theoretically. He said that, after the discovery of the TN mode, he was proud of that for a while, but soon after found other problems in physics to attack. He added that I would never find any written material about the TN effect at the David Sarnoff Research Center. Though Heilmeyer did not recall Helfrich explaining the TN mode to him, Castellano, who had shared the office room with Helfrich, confirmed that Helfrich had conceived the TN mode when he had been with RCA. Alan Sussman also believed that Helfrich had conceived it in RCA. Helfrich's coinventor Schadt, now heading Rolic Ltd. in Basel, Switzerland, confirmed that Helfrich had brought the idea of TN mode from RCA. Helfrich must have conceived the idea of TN mode while he was with RCA Laboratories, sometime before he moved to Hoffmann-La Roche in October 1970.



Fig. 18. Helfrich in 1976.

B. Discovery of Twisted-Nematic Mode by Fergason

The concepts that led to the TN mode were also formulated on the other side of the Atlantic. James Fergason used to work for Westinghouse Electric Corporation in Pittsburgh, PA, where, in 1959, he invented a room-temperature color range meter using cholesteric liquid crystals [6]. He moved to the Liquid Crystal Institute of Kent State University, Kent, OH, as Associate Director. Later, he established the International Liquid Xtal Company in Kent, OH.

To arrive at the TN mode, one has to combine the three concepts associated with nematic liquid crystals. First, the nematic liquid crystals exhibit a helical twist when they are sandwiched between cross-grooved plates. Second, the linearly polarized light incident perpendicular to the plates rotates its direction of polarization along the helical twist. Third, if the liquid crystals are positive, an electric field perpendicular to the plates reorients the long axis of the liquid crystals to the direction of the incident light and, thus, eliminates the rotation of polarization. By using two polarizers, one would be able to devise a light switch controlled by an electric field.

In August 1968, Fergason described the concept of helical twist and rotation of linearly polarized light [34]. Then, in January 1970, he reported the concept of reorienting nematic liquid crystals by applying an electric field [35].

He filed a patent on liquid crystals on February 9, 1971. The patent application was later abandoned and was replaced by five related patent applications [36]–[40]. In the patent application of April 22, 1971 [36], the above three concepts were merged into the single concept of an optical shutter controlled by an electric field. He used a mixture of 40% bis-(4'-n-octyloxybenzal)-2 chlorophenylenediamine, 50% p-methybenzal-p'-n-butylaniline, and 10% p-cyanobenzal-p'-n-butylaniline, which was nematic over a substantial temperature range, including room temperature and was of p-type. The description is on the normal white case. The patent shows that Fergason arrived at the same TN effect at some other place and almost at the same time.

When I asked Fergason in 1995 how he could have applied for a patent in April 1971 if he had already published

the idea in 1968 [34] and in 1970 [35], he showed me a non-public document “Liquid crystal nonlinear light modulators using electric and magnetic fields.” The document contained a full account of the concepts of the TN mode. The document said: “The invention was conceived on December 30, 1969. The invention was explained to Ted R. Taylor and Thomas B. Harsch the same day. The invention was first reduced to practice on April 5, 1970.” Taylor and Harsch, who countersigned the document, were the coauthors of his 1970 paper [35]. He said that the examiner at the U.S. Patent Office recognized the importance of the descriptions in the *electro technology* paper. The patent application of April 1971 was granted in the U.S. and also in Germany.

C. Patent Settlements

The Helfrich and Schadt’s patent application was filed on December 4, 1970 in Switzerland [23] and the Fergason’s TN patent application was filed four and half months later on April 22, 1971 in the U.S. [35].

According to Schadt, this sparked a fierce legal battle over ownership of the invention. They eventually settled the issue out of court, whereby Hoffmann–La Roche bought out the right of Fergason’s U.S. patent. According to Fergason, Hoffmann–La Roche agreed to buy out the patent rights of the International Liquid Xtal Company in the U.S. The April 1971 patent had been originally assigned to the International Liquid Xtal Company and later its ownership was transferred to Hoffmann–La Roche. However, Fergason said that Hoffmann–La Roche had failed to make the second payment. He, therefore, filed a lawsuit against Hoffmann–La Roche for failure to honor the contractual obligations and not for any claim in the U.S. to the invention. The court battle against Hoffmann–La Roche lasted three months. International Liquid Xtal Company could not financially afford to continue the battle and settled out of the court. As a result, the Fergason’s other five patents [37]–[41] were assigned to Hoffmann–La Roche.

D. Transmission Minimums in Normally Black Case

It was later revealed that the propagation of light through the TN cell in the OFF state was more complex than the simple picture shown in Fig. 16(a). The fact became important when the AM drive was later developed for color TV displays. In the idealized situation for the normally black case, the transmission through the cell is zero. Actually, a linearly polarized light entering from the top plate becomes elliptically polarized as it passes through the twisted liquid crystals and the light may leak from the bottom plate. In 1974 C. H. Gooch and H. A. Tarry of the Services Electronics Research Laboratory of the U.K. reported that optical birefringence and cell thickness are significant parameters affecting the transmission efficiency of the TN mode [42], [43]. The transmission t may be expressed as

$$t = \frac{\sin^2 \left[\Phi (1 + u^2)^{1/2} \right]}{1 + u^2} \quad (7)$$

where $u = \pi \Delta n d / \Phi \lambda$, Φ is the twist angle, and λ is the wavelength of the light. Fig. 19(a) exhibits the transmission

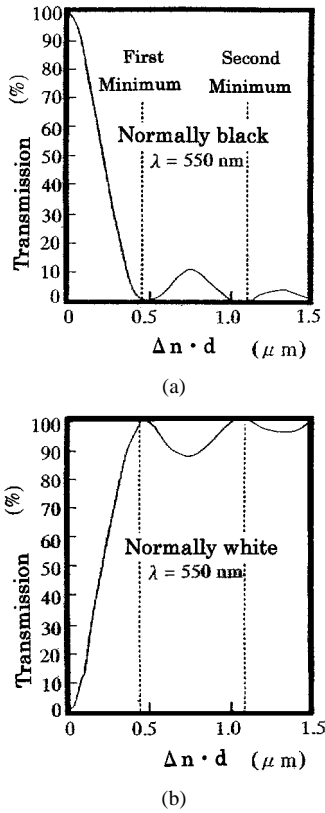

Fig. 19. Transmission minimum and maximum [44]. (a) Transmission versus $\Delta n \cdot d$ for the normally black case, exhibiting the first and second minimum. (b) Transmission versus $\Delta n \cdot d$ for the normally white case.

as a function of $\Delta n d$ for a wavelength of 550 nm [44]. To achieve the minimum transmission, the cell structure has to satisfy

$$\left(\frac{\Delta n d}{\lambda}\right)^2 + \left(\frac{\Phi}{\pi}\right)^2 = M^2 \quad (8)$$

where M is an integer [45]. For a TN mode with $\Phi = \pi/2$ the first, second, etc., minima are obtained for $M = 1, 2$, etc.

$$\frac{\Delta n d}{\lambda} = (0.75)^{1/2}, (3.75)^{1/2}. \quad (9)$$

The TN displays used in watches and calculators in 1970s had liquid crystals with relatively large Δn values of 0.2 and cell gaps of about $8 \mu\text{m}$, yielding $\Delta n d/\lambda \sim 3$. A high value of $\Delta n d/\lambda$ was favorable because this condition made the optical appearance of the display relatively insensitive to minor thickness variation in the cell gap. However, layers thicker than $8 \mu\text{m}$ are unsuitable because the display response becomes too slow, since the response time increases with the square of the layer thickness. By the 1980s, a distributed spacer technology was developed to better control cell gap uniformity. In the AM drive (Section IX), fast response times and, therefore, thin cell gaps are important and an $M = 1$ condition, which is generally referred to as the first minimum condition, is often chosen. The first minimum condition ensures a wide viewing angle [46].

For the normally white case, a similar derivation and discussion are possible. The transmission for the normally white case is shown in Fig. 19(b).

E. Aligning and Tilting Nematic Liquid Crystals

For nematic liquid crystals to operate in the TN mode, their long axes are required to line up in one direction on the inner surface of the sandwiching glass plates. Nematic liquid crystals are known to lie on a polyimide surface and to align in parallel to the direction of microgrooves carved in the polyimide surface. To carve the microgrooves, the method widely used throughout the industry is to coat polyimide on the ITO covering the glass and then rub with cotton cloth. The origin of the technique of rubbing goes back to 1928 far beyond the time of discovery of the TN mode in 1970 [25], [26].

It had been believed the morphology of the rubbed surface forces nematic liquid crystals to align in the direction of carved grooves [47]. In 1992, Tatsuo Uchida and his group of Tohoku University studied the rubbed surface using an atomic force microscope (AFM) [48]. They spincoated polyimide on the ITO covering the glass. Fig. 20 shows a micrographic picture of such a polyimide surface before the rubbing. The surface of polyimide is crowded with randomly positioned bumps whose heights are typically 25 \AA and typical widths of 2000 \AA . By observing the surface of noncoated ITO, he found that such bumps had originally existed on the surface of ITO. Then, he rubbed the surface of polyimide with velvet. Fig. 21 shows a micrographic picture taken after the rubbing. Now, the surface of the polyimide exhibited the desired microgrooves. The direction of microgrooves was found to be in the same direction as the rubbing. The pitch of the microgrooves was from 600 to 2500 \AA and the height from 10 to 100 \AA .

Considering the lengths of the long axis of nematic liquid crystals being typically 30 \AA and having observed the widths of the grooves being wider than 600 \AA and the heights of the grooves being lower than 100 \AA , it is difficult to consider that only the morphology of the grooves forces liquid-crystal molecules to align in the groove direction. The liquid-crystal molecules could align in any direction in the wide-pitch grooves. As a matter of fact, it has been reported that a surface coated with a gelatine had aligned liquid crystals at an angle of 45° to the direction of rubbing [49]. Using the elastic continuum theory, Uchida calculated the azimuthal surface anchoring strength from the morphology of the carved surface. He also experimentally measured the azimuthal surface anchoring strength. It was found that the experimental value was much higher than the value calculated based on the surface morphology, suggesting that the anisotropy of surface morphology does not contribute significantly to the alignment of liquid crystals on the rubbed surface. The Tohoku team considered the alignment to have been caused by an effect such as an intermolecular interaction (steric, dipole-dipole, or dispersion interaction) between the liquid crystals and polymer molecules. It has been found that by rubbing, the chain molecules at the polyimide surface are pulled and aligned in the direction of rubbing [50].

Currently, there are two major schools on the mechanism of surface alignment: microgroove morphology and intermolecular interaction. Recent comparative studies seem to indicate that both mechanisms are at work [50]. In the case

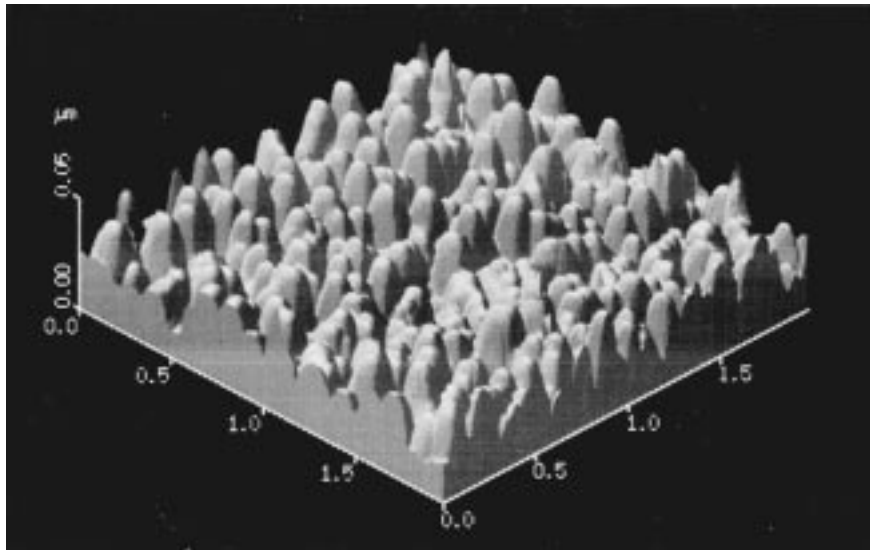

Fig. 20. ATM micrographic picture of polyimide surface before rubbing. Courtesy of T. Uchida.

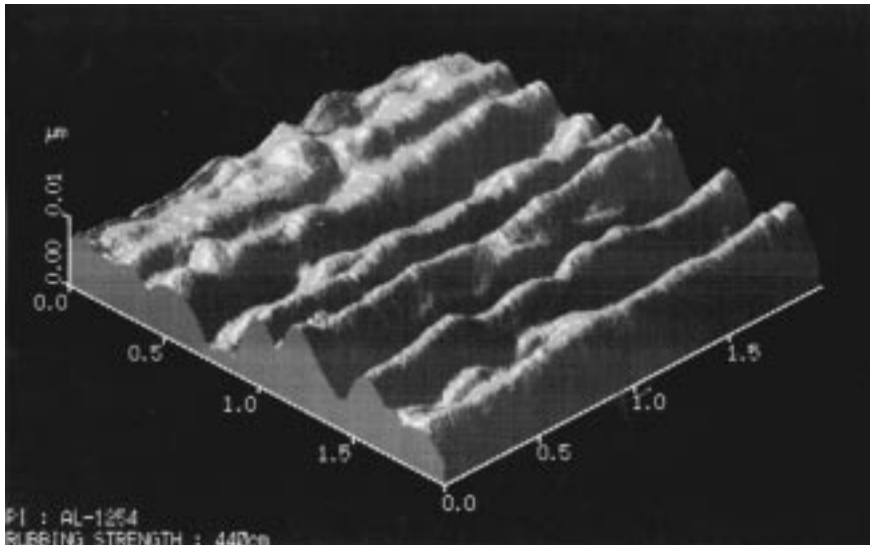

Fig. 21. ATM micrographic picture of polyimide surface after rubbing. Courtesy of T. Uchida.

where polyimide is used as a surface coating, the two mechanisms may be cooperating to assure that nematic liquid crystals align in the rubbing direction [51].

It has also been known that the rubbing gives a pretilt to the molecules lying in the grooves. Generally speaking, if the rubbing is done in the left to right direction, the right end of the molecule is slightly lifted. The angle of tilt can be controlled by changing the chemical components of the polyimide.

Various new methods—oblique evaporation, Langmuir-Blodgett formation, unidirectional stretching and groove formation by stamping—have been proposed to replace the rubbing method. Interestingly, though a thorough understanding of its physical mechanism is yet to come, this simple and rather crude method of rubbing a polyimide surface works surprisingly well and has been used throughout the LCD industry to the present day.

VI. CYANOBIPHENYLS—THE FIRST COMMERCIALY USABLE LIQUID CRYSTALS SYNTHESIZED IN THE U.K.

The liquid crystals used in display applications have to be of nematic type at room temperatures. When RCA discovered the DSM in 1964, liquid crystals exhibiting a nematic phase at room temperatures did not exist. In 1967, RCA developed Schiff's bases [15] (see Fig. 22) and found that by mixing similar kind liquid crystals they could achieve a freezing temperature lower than the lowest freezing temperature among the mixture's components. For instance, the freezing temperature of their G mixture consisting of three Schiff's bases was 22 °C, while the lowest of the freezing temperatures of the three mixture components was 49 °C. Such mixtures were used in the prototypes demonstrated at the RCA's 1968 press conference. It is worth noting that Farbwerke Hoechst published a paper on MBBA in 1969 [18]

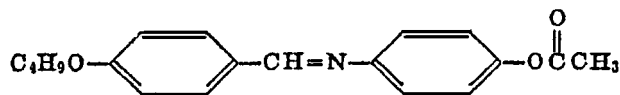

Fig. 22. Schiff's base used in the DSM devices demonstrated at the 1968 RCA press conference.

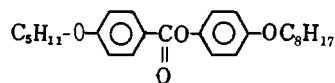
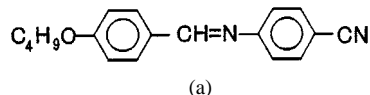

Fig. 23. Negative ester used in a DSM watch display.

(see Fig. 12). The MBBA exhibited a nematic phase between 21 °C–47 °C and was of n-type. Wada used the MBBA and its homologues in his pocket calculator. MBBA falls into the general category of Schiff's bases and it is easily hydrolyzed. If the fabrication process is not perfect, however, an undesired impurity such as water might migrate into the mixture or, if the seal of the device is not perfect, moisture might leak into the device. Because of the hydrolysis problems, a display consisting of MBBA was extremely difficult to fabricate correctly. In 1970, Dietrich Demus *et al.* of Halle University developed negative esters [52] (see Fig. 23). They did not have the hydrolysis problem and esters were used in a DSM display intended for use in watches, which was exhibited at the 1972 International Fair of Leipzig. However, esters had a high viscosity and, therefore, their time response was slow, typically with a turnon time of 40 ms and turnoff time of 200 ms at room temperature, and, thus, were not used for commercial applications. Besides, the DSM itself in which MBBA and esters were operated required substantial improvements in its physical characteristics such as power consumption, transient response, and image contrast. The new TN mode exhibited favorable characteristics such as very small power dissipation and high image contrast. If the viscosity of a material is made low, its transient response can be expected to be fast. Having read the article on the TN mode, the scientists and engineers who were concerned with LCDs started a search for positive liquid-crystal materials for use in the TN mode.

In 1967, Castellano invented alkoxy-cyano-Schiff's bases for use in the guest-host mode [32]. One end of the Schiff's bases was replaced with a -CN radical, which had a strong dipole moment [see, e.g., Fig. 24(a)]. The alkoxy-cyano-Schiff's bases exhibited a strong p-type. In 1972, alkyl-cyano-Schiff' bases were synthesized specifically for use in the TN mode [33] [see, e.g., Fig. 24(b)]. However, these Schiff's bases were again found to be easily hydrolyzed and, thus, were not suitable for display applications. In 1970, H. Kelker of Hoechst synthesized new materials based on azoxy compounds [53] and E. Merck offered such materials to display makers [54] (see Fig. 25). They were relatively low in viscosity (34 cP at 20 °C) and, thus, had a fast transient response. They were of n-type, but could be doped to be a p-type. Suwa Seiko used them in its first digital watch and Sharp used them in a new TN-type pocket calculator. However, the compounds were colored yellow; hence, displays for the digital watch and pocket calculator were yellow. They had an absorption in



(a)

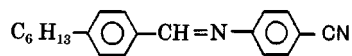

(b)

Fig. 24. (a) Alkoxy cyano-Schiff's base used for guest-host mode and in the first TN experiment. (b) Alkyl cyano-Schiff's base used in TN experiments.

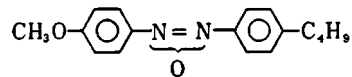

Fig. 25. Azoxy used in the first TN watch.

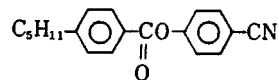

Fig. 26. Positive cyano ester used as an additive in the first TN watch.

the visible range and, thus, were chemically unstable when they were exposed to light, since they absorbed light energy at the absorption maximum. To obviate this, the display had to have a yellow cut filter. In 1972 Hoffmann-La Roche synthesized positive cyano esters for use in the TN mode [33] (see Fig. 26). (According to Demus, his 1970 patent [52], which describes negative esters for use in the DSM, also covers positive cyano esters in the frame of German patents right at the time.) The esters did not have absorption within the visible range and were stable against water and oxygen. They had a $\Delta\epsilon$ as high as +30 and, thus, gave a low threshold voltage V_C . Seiko used them in their digital watch. However, the cyano esters had a viscosity as high as 100 cP, which made them unfavorable for use in display applications. They have been used as additives for the purpose of lowering V_C of a mixture. Display manufacturers were yet to find a positive liquid crystal that was colorless, stable, low in viscosity, and operable at subzero temperatures. The above TN materials were forerunners of a new material yet to come from the U.K.

A. U.K. Liquid-Crystal Program

The story of liquid crystals in the U.K. is detailed in "The anatomy of a discovery—biphenyl liquid crystals" by Cyril Hilsum [119]. He was a well-known gallium arsenide semiconductor physicist who at the time was leader of the Display Section at the Royal Radar Establishment (RRE), the search arm of the British Armed Forces, Malvern, U.K. He also was Chairman of the Committee for Valve Development (CVD) Display Devices Committee. His paper is very instructive and intriguing and is quoted almost verbatim in some of the following.

The story really begins with one man and it is strange to think that the U.K. liquid-crystal fraternity will always be indebted to him. He was the Minister of State for Technology, John Stonehouse. In 1967, Stonehouse paid his first visit to the RRE. His conversation with RRE Director George MacFarlane ranged over many topics including the financial re-

turn from inventions. McFarlane pointed out that the U.K. paid royalties to RCA on the shadow-mask color TV tube which were more than the development costs of the Concorde. Early the next morning, he rang the director and said he was convinced that the U.K. should mount a program to invent a solid-state alternative to the shadow mask tube. He summoned to his office David Parkinson, then Head of the Physics Group, and Hilsum. He explained his situation and asked what the chance was of the RRE making a solid-state flat-panel color TV. Parkinson turned white and Hilsum said: "None whatever." Neither response offered the basis of a constructive reply to the Minister, so they agreed on the conventional civil service reaction—they set up a working party to study the topic.

This was how Stonehouse initiated the research on liquid crystals aimed at the flat display to replace the CRT in the U.K.³ Parkinson first chaired the working party, but in 1968, Hilsum took over the chairmanship. He asked Leslie Large, a scientist in the CVD, to organize a meeting on liquid crystals. There is no written record of that meeting, but it remains fresh in the minds of several participants. The meeting was packed with attendees, including admirals and generals. The high point was a review on the liquid crystals by a person then regarded as a leading authority. At the end of the authority's talk, Hilsum called for questions. There being none, he attempted to fill an embarrassing gap and, having noticed that the light from the slide projector reflected from his liquid-crystal sample cast a curiously shaped and patterned curve on the screen, asked the speaker how this happened. The speaker attempted an explanation, realized it was wrong, remembered a reference to the phenomenon in a book he carried, rapidly turned the pages of this book, decided that the reference was in his loose notes, opened these, dropped both the notes and the book, and then knelt on the floor picking up the pieces. The meeting was rapidly unraveling when a quiet voice from the back of the room said: "I wonder if I can help." Hilsum lifted his eyes from the groveling body of his key speaker and replied: "I'd be most obliged if you would" and his rescuer proceeded to give a sufficient explanation. That was the first time he met George Gray of Hull University. At the end of the meeting, when Large asked if they had reached any conclusions, Hilsum replied: "Yes, we must put the man from Hull on a contract."

In October 1968, Hilsum heard the news of the announcement of the invention of an LCD from RCA, demonstrating the DSM, albeit at temperatures between 77 °C–90 °C. RCA claimed to have a proprietary mixture operating at room temperature, but gave no details.

For a year, nothing worthy of mention happened in the U.K. on liquid crystals. The working party ground away. Only in October 1969, one year after the meeting of CVDs, did the first draft of the working party report appear, proposing work on eight topics, but excluding liquid crystals. The final version was issued in December 1969 and it

³After Stonehouse initiated the research on liquid crystals, his clothes were found on a beach in California. He was considered to have committed suicide by drowning, only later to be discovered living with his former secretary in Australia. He eventually found himself in jail for having confiscated funds from a company of which he had served as one of the directors.

differed from the draft in one crucial and fascinating respect. The relevant extract reads "One system is worth immediate attention. This is the display based on liquid crystals." The words "liquid crystals" were added afterwards.

The U.K. flat-panel display program had begun almost stealthily, with no drum-banging. Some of the effort at RRE gradually moved from semiconductors and lasers to electroluminescence and liquid crystals, with day-to-day supervision being in the hands of John Kirton. The record shows that in April 1970, Components, Valves, and Devices (renamed from CVDs) offered Gray a two-year contract to work on "Substances exhibiting liquid-crystal states at room temperature" at a maximum expenditure of £2177 per annum. Hull started work for the Ministry of Defence (MoD) in October 1970, with a team of two: Gray and a post-doctoral fellow John Nash. The program was run as a consortium between those interested in making liquid crystals and those interested in using them.

Gray received the Ph.D. degree from the University of London in 1953. His research on liquid crystals began in 1947 when he was a lecturer at Hull University, 17 years before Heilmeyer's discovery of DSM. He became a Professor of Organic Chemistry at Hull University in 1978. When I asked Gray how research in the U.K. and his own work was focused before the display application came about, he emphasized that U.K. activity had been at a fairly low level and was then of purely academic interest. He never envisaged the importance of liquid crystals until the news release by RCA in 1968 and was very excited by the announcement made at the Second International Liquid Crystal Conference, together with the involvement of the MoD. This changed the attitude of the University toward his research. His research became a shining example of collaboration; it was not "blue sky" research anymore, but its success owed everything to the earlier "blue sky" research on materials, before devices were conceived.

Gray worked on a variety of liquid-crystal materials including carbonate esters following reports from RCA. Few of the displays being sold could be guaranteed to operate for a long time. Schiff's bases gave erratic results because MBBA and similar materials were easily contaminated before the cells were sealed. Alternative materials, though always hailed as breakthroughs by their discoverers, were without exception deficient in some respect. Now, the consortium was showing considerable interest in TN cells. This increased the need for p-type materials. The teams at Hull and RRE had grown—at RRE early in 1971 by the recruitment of Raynes and at Hull late in 1971 by the formal inclusion of Ken Harrison.

The latest candidates at Hull, the stilbenes, were shown to degrade when exposed to ultraviolet radiation and Hull stopped work on them. They turned to stilbene esters and cyano-Schiff's bases [32]—the latter because mixtures based on them were positive and provided good TN cells.

B. Reverse Twist and Reverse Tilt

Raynes received the Ph.D. degree from Cambridge University in 1971. He had been working on superconductors

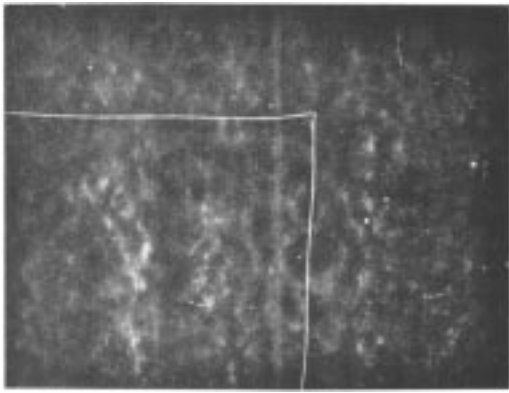

Fig. 27. Area of reverse twist [55].

at the University. At the time, RRE was looking to start a program on liquid-crystal devices and asked Raynes if he would be interested in going into liquid crystals. He thought that the superconductor field was becoming too abstract. He knew nothing about liquid crystals. However, what little he had heard made him think that there was a chance to do some good applied physics on potentially useful devices. So he changed fields and went to the RRE in 1971, before liquid-crystal devices were well known.

While the Hull team was working on the search for new materials, the team at RRE did not stay idle. In 1972, Raynes received samples of cyano-Schiff's bases from Hull. Using it in the TN mode, he found that the display had areas of different contrasts. He reasoned that the problem was due to two different causes: "reverse twist" and "reverse tilt."

The "reverse twist" showed up when there was no applied voltage [55]. As seen in Fig. 27, it appeared as a disclination line. The TN mode requires a 90° helical twist of nematic liquid crystals. By using an electro hydrodynamic motion (Williams domain), he found that some areas of liquid crystal were twisted by $+90^\circ$ and the others were twisted in a reverse direction by -90° . Along the boundary between the different twists, a disclination line appeared. In 1972, Sussman of Optel Corporation reported on a discovery he had made when he had been with RCA [56]: "If opposite faces of a cell are rubbed in nonparallel directions, the nematic liquid orientation, parallel to the direction at each face, will rotate uniformly from face to the other, either right handed or left handed. The presence of a small amount of optically active material may preferentially induce one of these equally probable twists." The solution Raynes developed was to add a small quantity of long-pitch cholesteric dopant to the host material, thus, making all the molecules of the nematic liquid-crystal twist in the same direction along the twist of cholesteric dopant [57]. A suitable value for p/d , where p is the cholesteric pitch length and d is the layer thickness, was found to be about 7 [57]. If p/d became too large, areas of reverse twist could form.

The "reverse tilt" showed up when areas of reverse twist were eliminated and when a voltage was applied [58]. As seen in Fig. 28, other patches became noticeable. Broad disclination lines appeared separating these patches. These

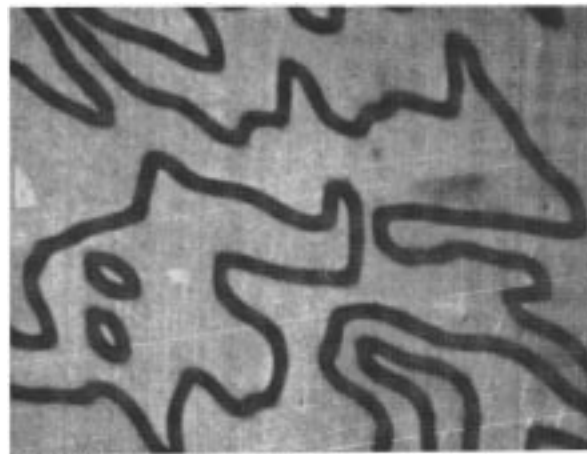

Fig. 28. Reverse tilt. Broad field-dependent disclination lines separating areas of opposite tilt [59].

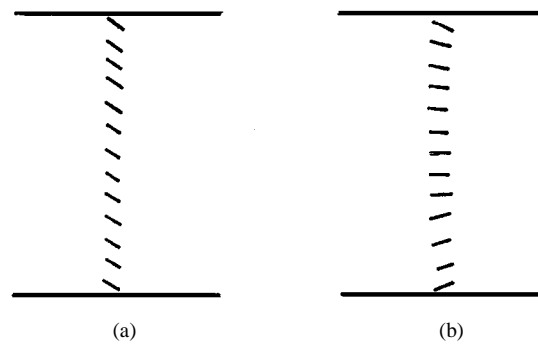

Fig. 29. Two possible configurations in nontwist layers with $\alpha_1 \neq 0$ and $\alpha_2 \neq 0$ [57] (a) Uniform (uniform tilt angle). (b) Splayed (varying tilt angle).

arose because the electric field induced both clockwise and anticlockwise reorientations of nematic molecules about an axis normal to both the electric field and the molecular director before the voltage application. Raynes explained this as being caused by the finite pretilt angle. Surface layers on which liquid crystals are lying with pretilt are either uniform (uniform tilt angle) or splayed (varying tilt angle) (Fig. 29) [57]. The uniform layers switched properly, whereas splayed layers showed problems. Patch-free displays require a pretilt angle α not equal to zero on at least one of the substrates. Large pretilt values ($\sim 25^\circ$) produced by evaporating a dielectric layer, e.g., SiO, were unsuitable because of the accompanying degradation of the optical properties. He found that unidirectional rubbing of a clean surface with tissue paper produced $\alpha \sim 2^\circ$. This was sufficient to produce a unique sense of reorientation without degrading the properties. Completely patch-free displays were produced by using both $\alpha_1 \sim 2^\circ$ and $\alpha_2 \sim 2^\circ$.

These methods of correcting the reverse twist and reverse tilt [58] made the later materials synthesized by Gray *et al.* acceptable to display manufacturers. According to Sussman, just before he left RCA in around 1971, he exposed his discovery of correcting the reverse twist [56] to an RCA attorney, whom he found was not interested in making the discovery a patent.

| | | Individual temperature range (°C) | Amount (%) |
|--------------|---|-----------------------------------|------------|
| C_5H_{11} |  | 22 → 35 | 51 |
| C_7H_{15} |  | 28 → 42 | 25 |
| $C_8H_{17}O$ |  | 54 → 80 | 16 |
| C_5H_{11} |  | 130 → 239 | 8 |

Fig. 30. Composition of E7 (C. Hilsium).

C. First Success

By the spring of 1972, Gray had tried most of the liquid-crystal chemistry he knew, working on at least four different families, all to no avail. The Hull group tried to work out the feature common to the unsuccessful experiments and gradually the concept emerged that the problem was the central linking group such as $-CN = N-$. The proposed structure was similar to the top three shown in Fig. 30. These systems were, in effect, the cyano-Schiff bases mentioned earlier (see Fig. 24) minus the central linkage.

Nash first made some of the necessary intermediates and Harrison synthesized the new materials and those were liquid crystalline. Pentyl-cyano-biphenyl (5CB) had an operating temperature range from 22 °C to 35 °C and pentyloxy-cyano-biphenyl (5OCB) worked from 48 °C to 69 °C [60]. Samples were quickly passed to Malvern for electrical, electrooptic, and stability tests and the news was all good [61]. The resistivity was high and was not reduced on exposure to a damp atmosphere and the transition temperatures were also unaffected. MBBA, given the same atmosphere exposure, showed a drop in the clearing point of about 3 °C per hour. The materials showed a large p-type and were used with excellent results in TN cells, with a threshold voltage as low as 1.1-V rms.

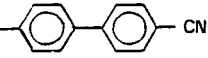
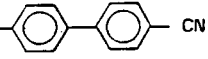
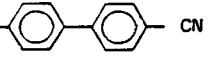
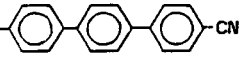
Hull and RRE were conscious that they had control of something with commercial value. The consortium documents were immediately marked "commercial-in-confidence" and code words were used to describe the materials. 7CB, 8CB, 70CB, and 80CB were quickly made and showed a more or less predictable trend in clearing points. No one material gave a practical operating temperature range, but the range in properties indicated that suitable mixtures should generate a wide enough range. A binary mixture of 5CB with 80CB worked from 4 °C to 50 °C and a quaternary mixture of 7CB, 8CB, 50CB, and 70CB from -3 °C to 52 °C. There was an immediate demand from the users in the consortium for samples and for RRE to discover mixtures with still wider operating ranges. The quantities needed were obviously beyond the resources of Hull and it was resolved to approach a chemical company, British Drug

House Ltd. (BDH). BDH accepted the work on December 1, 1972 and provided the first samples of 5CB within three months, even before they had recruited additional staff.

D. Liquid Crystals That are Nematic at Subzero Temperatures

By the spring of 1973, Gray and his group were happy about their new discovery, but were becoming concerned about the methods of choosing optimum mixtures from the large selection theoretically available to them. Six alkyl and six alkoxy derivatives had been synthesized and dozens of binary, ternary, and quaternary mixtures formulated, but it was a hit-or-miss procedure. It was desirable to make eutectic systems, but it would have taken far too long to plot eutectic diagrams for all the possible combinations. It was now that Raynes made what proved to be a crucial contribution. He deduced an extension to the Schröder-van Laar equation whereby knowledge of thermodynamic data for individual materials led simply to a prediction of the properties of the mixture [62]. The method was immediately accurate and extremely useful. Melting points of eutectic mixtures were predictable to within 5 °C and clearing points to within 2 °C. In nearly all cases the melting point was 3 °C–5 °C below the predicted value, so an empirical correction was simple. It became clear from the predictions that many quaternary mixtures would give an operating range as wide as 60 °C, with a melting point near or a little below zero.

Though these mixtures, with the prime advantage of high stability, would be far superior to anything else available, the range required by many display manufacturers was -10 °C to +60 °C. They were close, but not quite there. Gray once again exploited his wide experience of liquid-crystal chemistry and reasoned that the terphenyl system would give a much higher clearing point and when mixed with biphenyls would give a wider range mixture. The idea was interesting, but the materials were difficult to prepare. There were alternative materials that might perform the same task and Hull divided their efforts between these routes.

The discovery of the biphenyls had been published in March 1973 [60] and created considerable excitement. Many workers wanted samples and several manufacturers wished to make the materials under license. BDH was frantically busy trying to make enough material to satisfy demands from the consortium and potential customers and to make up and test the new mixtures proposed by Raynes. They were concerned about the purity of the BDH materials—and anxious not to sell prematurely, so giving biphenyls a bad name.

In September 1973, an additional complication arose. Glaxo, the owner of BDH, sold the firm to E. Merck of Darmstadt in Germany. The MoD was concerned about this, since Merck had begun selling liquid crystals and had an excellent group of research chemists. There was some risk that Merck would want to transfer production to Germany. In the event, nothing dramatic happened. The Merck board was anxious not to disturb the close relationship between BDH, Hull, and RRE and they carried on their work as before. In November 1973, BDH announced the commercial

availability of “exciting new liquid crystals,” including four eutectic systems E1—E4. E4 was thought to be the most useful for displays, with an operating range from 4 °C to 61 °C. BDH then increased their staff and appointed a product manager, Rob Wilcox.

Sales did not proceed as smoothly as Hull and RRE had expected, but BDH refused to be ruffled. The main problem was that the large display manufacturers had developed processes specific to their own proprietary mixtures and they were reluctant to change in midstream. They knew that the life of their displays was suspect, but hoped that their problems would gradually decrease. Wilcox had to persuade them to try biphenyls and RRE was heavily involved in devising changes to the accepted device processing schedules to suit biphenyls. In the first six months, only about 150 g were sold in the USA and slightly less in Japan. Rumors were being spread that biphenyls were carcinogenic and these were not fully countered by the proof that all of the biphenyls checked so far were nonmutagenic, as shown by the Ames test. Ironically, persuading people to buy something clearly superior to anything they had used previously seemed very difficult. For the scientists, the commercial world was most strange.

Late in 1973, Hull had synthesized pentyl-cyano-terphenyl and measurements of the melting point and clearing point, and fusion enthalpy showed it should be a most useful additive. The Raynes computer programs predicted that a ternary mixture including a terphenyl would give a wider range than a biphenyl quaternary mixture. Indeed, a mixture of 5CB, 7CB, and 5CT was predicted to work from 0 to 60 °C. There seemed to be just one problem: the tendency for any terphenyl excess over the exact eutectic composition to separate gradually as a solid. It was, therefore, essential to determine the composition of eutectics precisely and this took time. Late in August 1974, Raynes made a eutectic of 5CB, 7CB, and 80CB and 5CT with a nematic range of $-9\text{ }^{\circ}\text{C}$ – $59\text{ }^{\circ}\text{C}$. In almost all respects, it met the specifications put out by pocket-calculator and watch manufacturers. It was christened E7 (see Table 1 and Fig. 30). All of the components except the terphenyl were by now available in quantity and BDH sent samples abroad as fast as they could make the terphenyl.

The discovery of E7 in 1974 marked the end of this phase of work. The priority was now in marketing and supporting the BDH team, skilled in the economic production of complex chemicals, but unfamiliar with the physics problems of displays. Cyanobiphenyls exhibited a nematic phase at room temperatures, were chemically stable, did not have absorption in the visible range, and had low viscosity. These favorable characteristics made the materials the king of liquid-crystal materials for the ensuing ten years. Because the center of gravity of display production had moved steadily from the USA to Japan from 1973 onward, it was crucial to secure the Japanese market. In 1973, Sharp had marketed a pocket calculator based on the MBBA and DSM. In need of high reliability, high contrast, and fast time response, they searched for a new material to operate in the TN mode. By mid 1975, Wilcox persuaded Sharp to change to E7 and Sharp agreed to purchase one ton of biphenyls

Table 1
E7 Cyanobiphenyls as a Display Material (C. Hilsum)

| Property | Requirement | E7 |
|-------------------|--|---|
| Nematic range | $-10\text{ }^{\circ}\text{C}$ to $+60\text{ }^{\circ}\text{C}$ | $-9\text{ }^{\circ}\text{C}$ to $+59\text{ }^{\circ}\text{C}$ |
| Threshold voltage | <1.0 volt | 1.2 volts |
| Resistivity | $>5 \times 10^{10}$ ohm.cm | 5×10^{10} ohm.cm |
| Response time | <50 ms | 35 ms |
| Colour | none | none |

per annum. In 1976, they introduced a pocket calculator based on the cyanobiphenyls and the TN mode [63]. Suwa Seiko also succeeded in marketing digital watches taking advantage of the discovery of the TN mode and the synthesis of cyanobiphenyls (see Section VII) [64]. In 1977, BDH was the largest manufacturer of liquid crystals in the world and biphenyls became their largest selling product. Cyanobiphenyls satisfied most needs for liquid-crystal materials worldwide. The biphenyls were licensed by the U.K. MoD to BDH, Merck, and Hoffmann–La Roche. Biphenyls have been used in TN numerical displays to the present day.

E. Phenyl Cyclohexanes

This does not mean the biphenyls had no rivals. In 1973, Demus and his group developed cyclohexane esters by replacing one of phenyl rings of cyano esters (see Fig. 26) with a cyclohexane [65] (see Fig. 32). With this structure, they succeeded in substantially lowering the viscosity of the esters. The cyclohexane esters have been widely used in pocket calculators to adjust the V_C of their TN cells. Later, various cyclohexanoates were developed. The most important of those was phenyl cyclohexane (PCH), synthesized by the Merck group.

The first attempt by Merck to get involved in liquid crystals goes back to 1907 when Merck offered liquid crystals for laboratory use (see Fig. 2). Their modern engagement with liquid crystals started when small activity about liquid crystalline reagents was initiated in chemical research of the company in Darmstadt, Germany. In early 1968, they started synthesizing new liquid crystalline aromatic esters, Schiff’s bases, and azo- and azoxy-compounds mainly for use in molecular spectroscopy.

In August 1968, Ludwig Pohl attended the Second International Liquid Crystal Conference held at Kent State University, where he learned about RCA’s inventions of LCDs. Based on his report in which the potential of liquid crystals for display applications was pointed out, Merck’s research route was changed. From then on, all work focussed on new nematic liquid crystals suitable for dynamic-scattering and guest-host displays. Parallel to a chemical laboratory, a physical laboratory was set up, headed by Pohl for the evaluation of isotropic and anisotropic properties of liquid crystals and for the development of liquid-crystal mixtures ready for use in display applications. In 1970, Merck offered new room-temperature liquid-crystalline azoxybenzenes for dynamic scattering displays. However, after the invention of the TN cell in 1970, they looked increasingly for liquid crystals of p-type. The liquid-crystal laboratories grew up to research



Fig. 31. British and European brains for liquid crystals. From left to right in front: Alfred Saupe, Frank Leslie, George Gray, Cyril Hilsum, Alan Leadbetter, and Harry Coles. In back: Geoffrey Luchhurst, Martin Schadt, Peter Raynes and John Goodby (*Liquid Crystals Today*, vol. 4, no.1, p. 3, 1994).

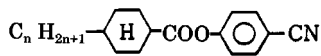

Fig. 32. Cyclohexane ester, which has been used for adjusting V_C of TN cells.

and development departments. In 1973, additional laboratories were installed in Poole, U.K. (BDH) and at Atsugi, Japan, in 1979.

As the area of applications of liquid crystals expanded beyond pocket calculators and watches, the time response at low temperatures became important. The decisive breakthrough came in 1976 with the synthesis of a new liquid-crystal family by Rudolf Eidenschink [66], [67]. The family was similar to the cyclohexane esters with the central -COO- ring removed. It was also similar to the cyanobiphenyls with a cyclohexane ring substituted for one phenyl ring (see Fig. 33). This family, known as the phenyl cyclohexanes, particularly PCH, became very important because it had a lower viscosity thus rapid time response and smaller birefringent effects. PCH had been widely used in TN cells and later was used in AM TFT displays. Until the present, phenyl cyclohexanes represented the basic structure from which most liquid crystals were subsequently derived.

VII. THE DIGITAL WATCH—ANOTHER COMMERCIALIZATION ACCOMPLISHED IN JAPAN

At its press conference in 1968, RCA distributed various photographs showing the devices it had developed with the use of liquid crystals operating in the DSM. One was a digital clock fabricated by Zanoni (see Fig. 34). The static display used in the clock did not have a proper sealing and the Schiff's bases used in the display had a hydrolysis problem. Bob Lohman, who posed in the picture, said: "The clock lasted just long enough to take a picture." The commercialization of clocks proceeded haltingly. In 1975, Sharp developed a clock named the "Magic Clock" [68] (see Fig. 35). The clock was an ordinary round mirror. When the user touched the frame, a clock display appeared on the face of the mirror. It was a luxury item and sold well as a gift to

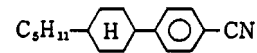

Fig. 33. Phenyl cyclohexane, a base material from which most liquid crystals for STN mode and AM drive have been derived.



Fig. 34. The first liquid-crystal digital clock.



Fig. 35. Magic Mirror Clock. Courtesy of Sharp Corporation.

newlyweds. The clock used MBBA mixtures and operated in the DSM. Washizuka recalls that the clock was extremely difficult to fabricate. Burying a liquid-crystal cell in the mirror made the structure complicated and the display area was substantially increased compared to a pocket calculator, making the job of sealing the cell extremely difficult. Sharp soon stopped manufacturing the Magic Mirror Clock.

As for wristwatches, RCA investigated watch displays with the encouragement of Timex Corporation, who had previously found LED displays unsatisfactory. Timex found that the DSM display was also inappropriate. At the time of Christmas in 1970, Nunzio Luce and Zanoni *et al.* of Optel Corporation developed the first digital wrist watch having an LCD. Optel in 1971 and Micoma in 1972 introduced

such watches in the U.S. [69]. Sussman, then with Optel, recalls that the watch used Schiff's bases and operated in the DSM. However, the watch had two problems. First, the battery drained quickly because of the requirement of an ionic current. To save battery energy, Optel ran its watch at a 1/2 duty cycle. Second, the display packages containing the inexpensive, but moisture-sensitive Schiff's bases had to be tightly sealed. A person who was familiar with the digital watch industry at the time said: "Most watches became inoperable after a while" [69]. It is probable that since the sealing was not perfect, moisture leaked into the liquid-crystal cell, the Schiff's bases were hydrolyzed, and the device, thus, suffered serious reliability problems. In addition, the liquid-crystal material itself had quality and reliability problems. Negative esters (see Fig. 23) that did not have hydrolysis problem were used in the DSM display. Esters, however, had a slow response time. The attempts to fabricate clocks and watches based on the DSM mode were not considered commercial successes. Success would have to wait until a watch display based on the TN mode was developed.

A. Suwa Seiko Program

In 1965, Yoshio Yamazaki, graduating from Niigata University, joined Suwa Seiko, a well known Japanese watch maker. Educated as a chemical engineer, he was unique in the company of Suwa Seiko precision-mechanics engineers. Yamazaki's job was to develop chemicals such as lubricants for use in the mechanical parts of watches and plating techniques for the watch package. In 1968, he read an article in a Japanese newspaper with great interest: RCA had invented a new type of electronic display. The article showed the picture of the digital clock (see Fig. 34) and vaguely mentioned that the display used an organic material. He thought that he should explore the organic material for the purpose of using it in wrist watches and immediately started work. Later, he learned that the organic material had been liquid crystals. Knowing nothing about liquid crystals and finding no reference to them, he was in the dark. However, he soon found a color-range liquid crystal [6] and steadily started understanding the materials.

Eventually, he was able to synthesize a liquid-crystal mixture that worked at room temperatures and operated in the DSM. He applied for a patent, only to find Farbwerke Hoechst had already invented the same MBBA [18]. Yamazaki was not aware of the NHK documentary. If he had, he would have seen that Heilmeyer had drawn one of Schiff's bases from which MBBA was extracted. Yamazaki later said that then he would not have had to reinvent the MBBA.

Suwa Seiko then established a group to develop liquid-crystal watches and Yamazaki became responsible for the development of liquid-crystal materials and display panels. When he started liquid-crystal development, he had been told that the responsibility would be all his, if the development failed.

The development of digital watches are detailed in Yamazaki's article [70]. Much of the material has been taken from his article.

B. Display for Watches

The requirements for watch displays are more restrictive than pocket calculators. They include the following.

1) *Low Power Dissipation*: The button-type battery commonly used in watches must last at least one year. For an EPX-77 battery having a discharge capacity of 165 mAh to last for one year, the power dissipation of the watch must be less than 28 mW. The power dissipation of the display, only one of several components in the watch, has to be substantially lower than the 28-mW power dissipation. In addition, there was a desire to extend the battery life beyond one year to three or five years, which required a further reduction in the power dissipation of the watch.

2) *Compactness*: The space available within the watch was at most 4–5 cm² and it had to house a battery, a display, and the electronic circuits. In addition, watches were becoming thinner; hence, available space was decreasing.

3) *Operating Temperature Range*: The temperature of a watch when it is being worn is equal to that of the human body and is relatively constant. However, when it is not being used, the temperature varies in a range as wide as that for pocket calculators. Watches are required to operate in the temperature range of -10°C to $+60^{\circ}\text{C}$.

4) *Durability*: Watches are expected to last at least five years.

In addition to the requirements above, a watch display must be attractive, shock resistant, have a low driving voltage, a fast response time, and be able to accommodate design changes.

At the time, two viable candidates existed: 1) LEDs and 2) liquid crystals (see Table 2). LED display had favorable characteristics such as low driving voltage, high reliability, and the potential for miniaturization, but they had poor power dissipation. In the U.S., the digital watch industry first started with LEDs. The LED display, which was self-emitting and red in color, was well accepted. However, since the power dissipation of the LED was high and the battery life was at a premium, the watch was designed in such a way that the LED display was lit only when the user wanted to know the time and pressed a button. Using the LED watch was sometimes awkward; when people wanted to know the time while entertaining a visitor, they had to press a button, which might give the mistaken impression that they were impatient for the visitor to leave [71]. As a result, LED watches soon disappeared from the market.

C. Choice of TN Mode

The LCD had many favorable characteristics compared to the LED display. The candidate for the modes of operation at the time for watches were DSM, guest-host mode, and TN mode. Yamazaki tried DSM first. He felt that the Schiff's base hydrolysis problem could be avoided if the device was correctly sealed. However, unlike a pocket calculator, a watch had to operate continuously and the DSM required an ionic current. This made the battery drain quickly. Other problems were a rather high driving voltage and a slow response time. To maximize the contrast of the display, he

Table 2
Candidates for Display Elements for Digital Watch [70]

| Display Element | | Driving voltage | Power dissipation | Life | Response time | Operating temperatures | Driving circuit |
|-----------------|-----|-----------------|--------------------------------|-------------------------------|---------------|------------------------|---------------------|
| Liquid | DSM | 10~15V | 10~100 μ W/cm ² | >10 ⁴ H | 10~200ms | 0~70°C | C-MOS IC |
| Crystal | TN | 2~6V | <1 μ W/cm ² | >5 \times 10 ⁴ H | 10~200ms | -5~70°C | C-MOS IC |
| LED | | 1.5~2V | ~10mW/cm ² | >5 \times 10 ⁶ H | 100ns | -30~80°C | bipolar transistors |

had to use a mirror. The viewing angle was narrow, which meant that one had to adjust the angle of view to see the display. For these reasons, he did not choose DSM. With the guest-host mode consisting of nematic liquid crystals and pleochroic dyes, the display was colored. Operating voltage was relatively low and the viewing angle was wide. However the contrast was not large enough and life expectancy was unknown. As a result, he did not choose the guest-host mode either.

He chose the TN mode for its low power consumption and high contrast. Because of the low power dissipation and the low driving voltage for a TN cell, the power dissipation for the TN cell plus its driving circuits could be made at less than one-fifth the power dissipation for a DSM cell plus its driving circuits. Yamazaki recalled that the key to their success was switching to the TN mode at an early stage.

D. Choice of Azoxy Materials

In watch applications, selecting a liquid crystal with low threshold voltage was important for reducing the power consumption. From (5), the material should have large $\Delta\epsilon$ and satisfy $(k_{33} - 2k_{22}) < 0$. With the TN materials available at the time, a threshold voltage as low as 0.9 V and a 90% saturation voltage of 1.4 V were possible. It seemed possible to construct a system of oscillation, frequency divider, driving circuit, and display all operating from a 1.5-V battery, which would be ideal for watches. However at freezing temperatures, the contrast and response time became problems. After trying various materials, he chose a mixture comprising of five liquid crystals including azoxy materials (negative $\Delta\epsilon$ and low viscosity) (see Fig. 25) and cyano esters (highly positive $\Delta\epsilon$ and high viscosity) (see Fig. 26) as additives. The nematic range of the mixture was -10 °C-72 °C. The azoxy materials had an absorption spectrum in the visible range and was colored greenish yellow. He made the display very thin so that the color did not show up strongly. The material degraded when exposed to light. To protect the material from the degradation, he used a filter that cut yellow and light with shorter wavelengths.

E. Commercial Debt

The overall development went much smoother than Yamazaki expected. He performed accelerated life tests and

learned that the lifetime of the watch was at least 10 000 h. He knew the watch would operate in the temperature range of -10 °C-60 °C, though the numerals of some watches went out of focus when the temperature was subzero. He was concerned whether the watch could really stand up in the marketplace; he knew all the previous digital watches, which used DSM, had very short lifetimes. He received encouragement from one top executive responsible for the digital watch business. "Even if something went wrong," the executive said, "the loss would only be a matter of a few hundred million yens. Do whatever you have to do and don't worry about the results."

In September 1973, K. Hattori and Co. Ltd., which was handling distribution of Suwa Seiko watches, announced [72] the introduction of a digital liquid-crystal watch, the "06LC" (see Fig. 36). It used two CMOS LSIs. With the adoption of the TN mode, the black numerals were clearly seen. Using a 1.5-V 190-mAh UCC S-76 battery, the watch would operate for two years, assuming the user turned on a viewing lamp ten times a day each for one second. The price was 135 000 yen. Yamazaki was nervously watching the market place, hoping there would be no product returns from the dealers. He heard of an extreme case in which someone used the watch in a desert and had trouble, but that was all. The watch was well accepted and became the first commercial success for liquid crystals in the watch market. It was the first product to use the TN mode. It took advantage of the low driving voltage, low power consumption, and the high contrast of the TN mode. A long battery life resulting from low power dissipation was the most important factor for the success of the product.

F. Change to Cyanobiphenyls

As for the liquid-crystal materials, Yamazaki later changed the prime material from azoxy compounds to esters and marketed a product in 1975. Esters do not have optical absorption problems, require no filter, and their display is white. They did not have the hydrolysis problem, but their viscosity was high and thus their time response was slow.

When BDH of the U.K. started offering them, he quickly moved to cyanobiphenyls [64], with which he was able to satisfy the characteristics he needed for digital watches such as white color and subzero temperature operation. Yamazaki



Fig. 36. The first TN product: 06LC digital watch. Courtesy of Seiko Epson.

said that the second reason for the digital watch's success was he had access to the biphenyls. Seiko used cyanobiphenyls exclusively for volume production of digital watches. The biphenyls were later supplied by Merck. Seiko eventually used a mixture supplied by Chisso in Japan, which imported the biphenyls from Merck and synthesized its own mixture. With the TN operating mode and cyanobiphenyl material, the liquid-crystal watch industry took off.

G. Static Drive for Segment Scheme

The method first used to display numerals in pocket calculators and digital watches was the segment scheme. Seven segments, as shown in Fig. 37, are electrically wired outside of the display area. A pulse driving voltage was used rather than a dc driving voltage because the dc driving deteriorated the electrodes. Fig. 38 shows the pulsed voltages applied to one of the segments. In the ON state, pulses of ± 3 V are applied across the liquid-crystal cell. The pulse amplitude may be several times the threshold voltage V_C for the TN mode. In the OFF state, the voltage across the liquid-crystal cell is zero. As long as the display is limited to numerals, as in this case, it was possible to achieve a reasonably high image contrast even with the gradual t/v curve of the TN mode. The driving method may be called a "static drive."

H. Duty-Cycle Drive for Segment Scheme

The digital watch could have many different functions. Those functions were the following:

- 1) display of minute, second, date, day of the week, A.M. and P.M.;
- 2) a stop-watch function;

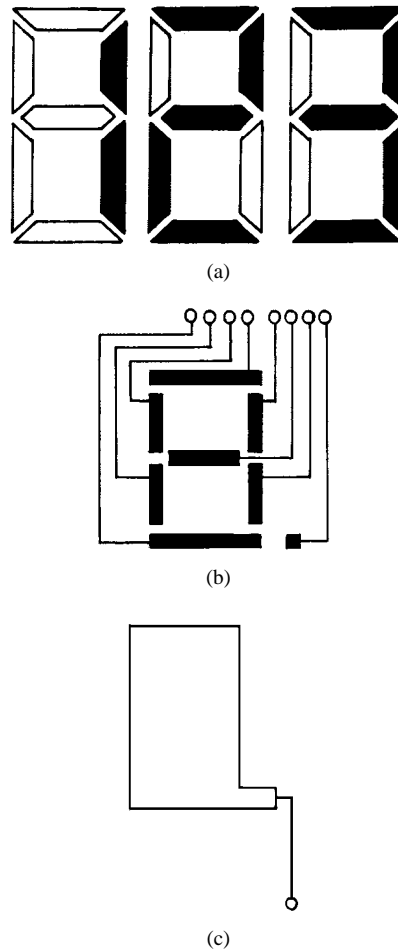

Fig. 37. (a) Segment scheme. (b) Upper electrode. Seven segments are arranged to form a figure eight and to exhibit numerals. Seven segments are wired to the outside of the display area. (c) Lower electrode.

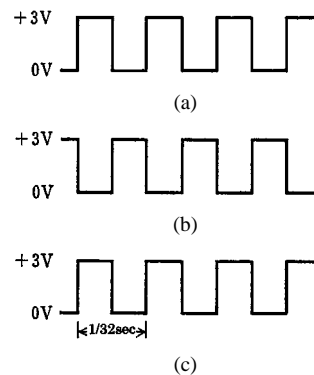

Fig. 38. Static drive waveforms [70]. (a) Voltage at the lower electrode. (b) Voltage at a segment when the segment is ON. (c) Voltage at a segment when the segment is OFF.

- 3) display of times around the world;
- 4) an alarm function;
- 5) a calculator function.

Some of the functions had already been installed in analog watches, but others became possible only because of the use of LCDs where the display contents could easily be changed. These new functions required an increased number of segments to which an increased number of leads are connected.

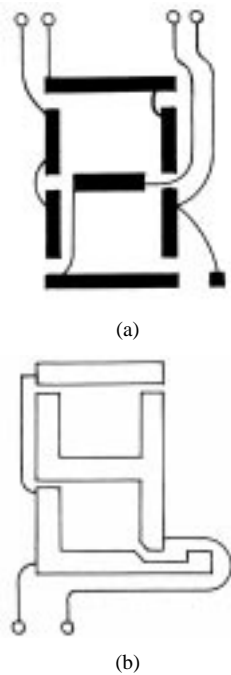

Fig. 39. Segment scheme for 1/2 duty-cycle drive [70]. (a) Upper and (b) lower electrode.

Soon managing the leads became very complicated. To alleviate the problem, the method for driving the display was changed to a duty-cycle driving method. Fig. 39 shows a segment scheme that uses such duty-cycle driving. The bottom electrode now is divided into two parts and, thus, is driven at a 1/2 duty cycle. Here, the number of leads has been reduced from eight for the static driving to six for the 1/2 duty-cycle drive.

As they wanted to further increase the information content of the display, the display engineers had to further increase the number of segments and soon found it unrealistic to make a large number of wire connections to all the segments. To solve this problem, the segment scheme evolved into a matrix scheme, which will be discussed in Sections VIII and IX. The use of the segment scheme is now limited to calculators and watches.

VIII. SUPER TWISTED-NEMATIC MODE—ANOTHER MODE OF OPERATION DISCOVERED IN EUROPE

By 1973, the TN mode and cyanobiphenyl liquid crystals were established and they were used almost exclusively in pocket calculators and digital watches. As a result, the pocket-calculator and digital-watch industries took off. The number of products kept increasing; for instance, the production of pocket calculators in Japan had been 10 million units in 1973, reaching 50 million units by 1981. However, from the 1980s, the production of calculators shifted outside of Japan and domestic production flattened out. Display engineers in Japan began focussing their efforts on developing devices that could display complicated alphabets and Kanji characters rather than just simple numerals. To achieve this, they moved from the segment scheme, which was suitable only for displaying numerals, to a matrix scheme. The TN

mode appeared capable of handling the driving of the matrix scheme. However, when the engineers wanted to increase the number of lines in the matrix to display high information content text and graphics, they found that the TN mode was insufficient. The solution to the problem again came from Europe.

A. Matrix Scheme

Except for pocket calculators and watch displays, almost all modern LCDs incorporate the matrix scheme. The matrix scheme may be classified into two categories: 1) simple-matrix addressing and 2) AM addressing (see Fig. 40). Simple-matrix addressing is primarily used in personal digital assistants (PDAs), cellular telephones, and word processors. AM addressing is used primarily in personal computers (PCs), camcorder monitors, and color televisions. This section describes the simple-matrix addressing and Section X describes AM addressing.

B. Simple-Matrix Addressing

Simple-matrix addressing works as follows. As shown in Fig. 41, the ITO electrodes on the upper glass plate are patterned into M columns and the ITO electrodes on the bottom glass plate into N lines. Hence, $M \times N$ dots can be addressed, thereby allowing the desired patterns to be displayed. Signals carrying picture information are applied simultaneously to all the columns and line-selection pulses are applied time sequentially to the lines. Therefore, the dots are activated only for a time T/N within a field period T (see Fig. 42). This simple-matrix addressing is sometimes referred to as multiplexed duty-cycle addressing.

In a practical display, the column electrode is cut at the midway point and the upper half is driven independently from the lower half, thus, making two separate displays that share the same substrate glass. This enables the number of matrix lines to be doubled while maintaining the same multiplexed duty cycle. For example, a matrix display panel of 240 columns \times 64 lines may have two subpanels each consisting of 240 columns \times 32 lines, where both subpanels are operated at a duty cycle of 1/32.

By 1982, a matrix display of 480 columns \times 128 lines with a 1/64 duty cycle had been achieved with the TN mode. To display graphics with higher information content, the engineers wanted to further increase the number of columns and lines. Suddenly, they encountered problems: increasing the number of lines higher than 128 or the duty cycle less than 1/64, caused the quality of the display to deteriorate, the time response to slow down, and the viewing angle to narrow. The biggest problem was that the contrast ratio of the display got so low that the display was difficult to read. To compensate for the loss of contrast, they raised the driving voltage only to find that crosstalk occurred; the signal on one dot leaked to neighboring dots. They tried various approaches such as new driving circuits and new liquid-crystal materials without much success. The engineers started to feel as if they came up against a brick wall. Achieving a large screen size with high information content appeared to be impossible.

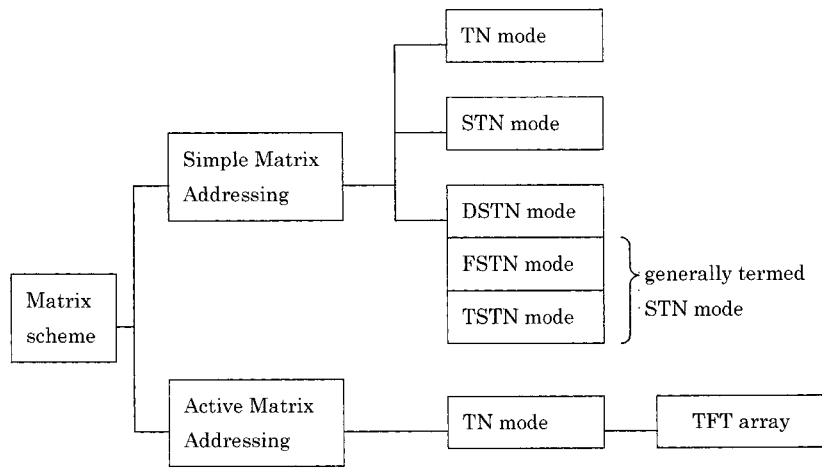

Fig. 40. Family of matrix scheme.

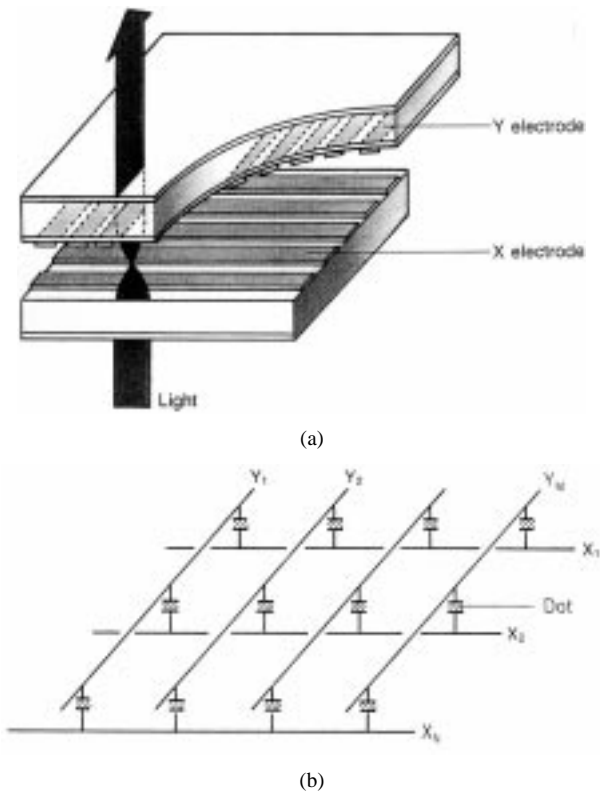

Fig. 41. (a) Structure of simple-matrix driving system. (b) Circuit.

C. Scanning Limitations of Simple-Matrix Addressing

Hideaki Kawakami of Hitachi [73] and Paul Alt and Peter Pleshko of IBM [74] independently analyzed the scanning limitations of LCDs. They considered the case of the DSM using simple-matrix addressing and used the fact that DSM device operate with an rms-averaged voltage. The result of their analyses is also applicable to the STN mode of operation. The IBM team showed that $P = \Delta V/V_C$ is a significant parameter in determining the number of lines that can be multiplexed in a simple-matrix display, where V_C is the threshold voltage and ΔV the voltage range of the steep part of the t/v curve (see Fig. 17).

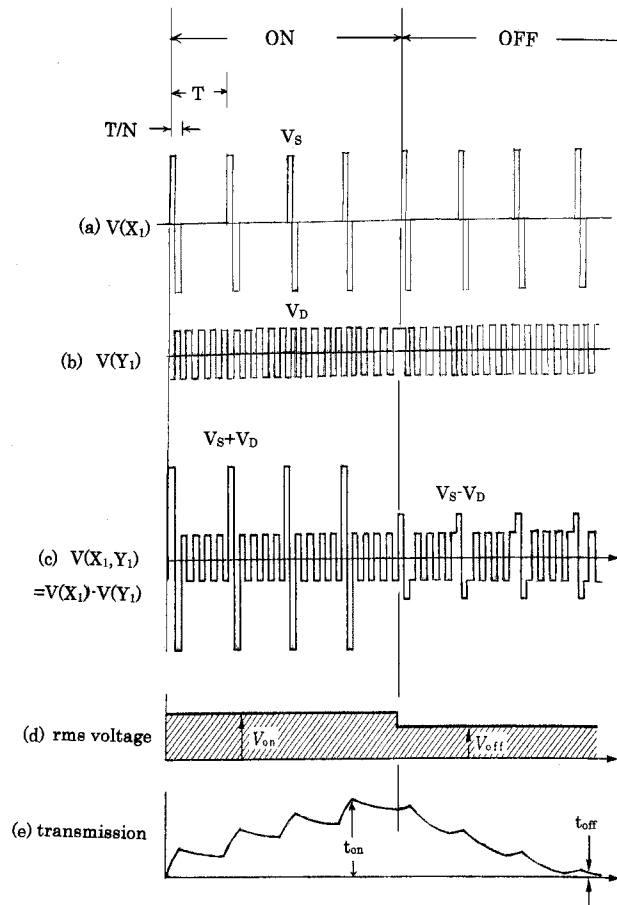

Fig. 42. Waveforms at a dot in a simple-matrix display [14].

Now, consider the case where the time constant of a liquid-crystal cell is large in comparison to the time period T/N for scanning one line on picture fields, which is met for most liquid-crystal cells in a simple-matrix scheme. Fig. 42 exhibits voltages applied on a dot (X_1, Y_1) in the $M \times N$ simple-matrix scheme; to avoid the dc deterioration problem, alternate-voltage pulses are used in driving the liquid-crystal cells. Fig. 42(a) exhibits the line selection pulse V_S supplied

through an X_1 electrode and Fig. 42(b) exhibits the data pulse V_D supplied through a Y_1 electrode. Fig. 42(c) shows the voltage ($V_S - V_D$) across the cell at (X_1, Y_1). When the cell is turned on, the phase of V_D is so adjusted that the voltage across the cell at its peak is ($V_S + V_D$). The response time of liquid crystals is much longer than the line period T/N and, for the transmission to reach a steady state, the cell has to be excited several times by the ($V_S + V_D$) pulse, as shown in Fig. 42(c). The cell operates on the basis of rms voltages and the rms cell voltage during the ON period is as shown by V_{ON} in Fig. 42(d), which is adjusted to be higher than ($V_C + \Delta V$). When the cell is turned OFF, the phase of V_D is reversed so that the cell voltage at its peak is ($V_S - V_D$) and the rms voltage across the cell is as shown by V_{OFF} in Fig. 42(d), which is adjusted to be lower than V_C .

Their calculation showed that under optimum driving conditions of

$$V_D = \left(\frac{V_C}{2}\right) [(1+P)^2 + 1]^{1/2} \quad (10)$$

$$V_S = \left(\frac{V_C}{2}\right) \frac{[(1+P)^2 + 1]^{3/2}}{(1+P)^2 - 1} \quad (11)$$

the matrix scheme will have the maximum number of lines N_{max}

$$N_{max} = \left[\frac{(1+P)^2 + 1}{(1+P)^2 - 1} \right]^2. \quad (12)$$

For small values of P

$$N_{max} \sim \left(\frac{1}{P}\right)^2. \quad (13)$$

For example, a device with $\Delta V = 0.7$ V and $V_C = 5$ V can be operated with simple-matrix addressing of $N_{max} = 59$ lines.

It should be emphasized that the only parameter affecting the number of scanning lines is the parameter P . A large threshold voltage or a sharp rise in the t/v curve will give rise to a larger number of scanned lines. Since the threshold voltage is often limited by the voltage of the battery, the only parameter we can vary is ΔV . Note that the turnon time for the device does not enter into the determination of the scanning limitations. This is because the transient response time of liquid-crystal cells is much longer than T/N and the number of lines is determined by a steady-state rms condition. However, the turnon time is of engineering importance, since the time it takes the panel to reach a steady-state ON level is proportional to this quantity. Similarly, the turnoff time for the device does not enter into a determination of scanning limitations, but the erasure time of the display is proportional to the decay time. Therefore, the steady-state condition determines the scanning limitations, while the transient behavior of the cell determines the write and erase time of the panel.

D. Materials for TN Simple-Matrix Display

Knowing that the parameter P would solely determine the maximum number of lines, research efforts were now focused on making the t/v curve steep.

First, materials having steep t/v characteristics were searched. It was discovered that the ratio of bend elasticity to splay elasticity k_{33}/k_{11} was a significant factor determining the slope of the t/v curve [75], [76]. The steepness of the TN cell was efficiently improved if k_{33}/k_{11} was less than one. The materials specifically for use in the TN simple-matrix driving were developed [77]; however, an N_{max} of 89 calculated from an experimental t/v curve in the article was not sufficiently large for panel engineers.

E. Super Twisted Guest-Host Mode

Colin Waters and Raynes of the Royal Signals and Radar Establishment (formerly RRE) in the U.K. turned their attention to the guest-host LCD mode (see Fig. 9) [78]–[81]. The guest-host mode has several advantages over the TN mode, such as a much-improved angle of view.

In 1982, they found that devices containing 270° of twist across the layer with either high pretilt or low pretilt exhibited extremely steep t/v ($\alpha = 30^\circ$) characteristics. In a high pretilt cell, they observed that ($V_C + \Delta V$) was 1.23 V and V_C was 1.15 V with a very slight hysteresis. The P value of $(1.23 - 1.15)/1.15 = 0.07$ suggested this device might be multiplexed up to 1/200 duty cycle. They considered that in the ideal case it would be possible to achieve an N_{max} as high as 500 [79]. However, the number of lines was reduced by a nonuniformity of cell spacing and ambient temperature.

They computer-simulated the t/v curve with changing twist angle and in 1984 found that both the threshold voltage and amount of hysteresis increased with the twist angle [80].

They actually demonstrated a 32-way multiplexed display with an excellent view angle [81]. However, the multiplexity was not as large as the display engineers wanted. The guest-host display was colored (a white display was desired for a future color display), the contrast ratio was still relatively low, and the high viscosity of the dyes was thought to cause a slow response. Nevertheless, it should be noted that in 1982, Waters and Raynes established the concept of a 270° twist, giving rise to a steep t/v characteristic. They thought that the high-degree twist could be applied also to the TN mode [78].

F. Super Twisted-Nematic Mode

For the display engineers to be convinced, they had to wait for the developments coming from Switzerland. The liquid-crystal research activities at Brown Boveri (BBC) started in 1969, at first in cooperation with Hoffmann-La Roche. BBC's Corporate Central Research Center started LCD work with the DSM. In 1970, as soon as room-temperature mixtures with a p-type became available, they shifted their efforts to the TN mode. Based on the work done in the Liquid Crystal Group, BBC started producing TN displays for use in watches in 1973. The Liquid Crystal Group at the time consisted of two professionals and three technicians. The group slowly grew to its final size of about eight to ten people, including three to four professionals. The liquid-crystal research was generally directed toward the improvement of LCD performance, specifically with respect to optical appearance and the number of picture elements.

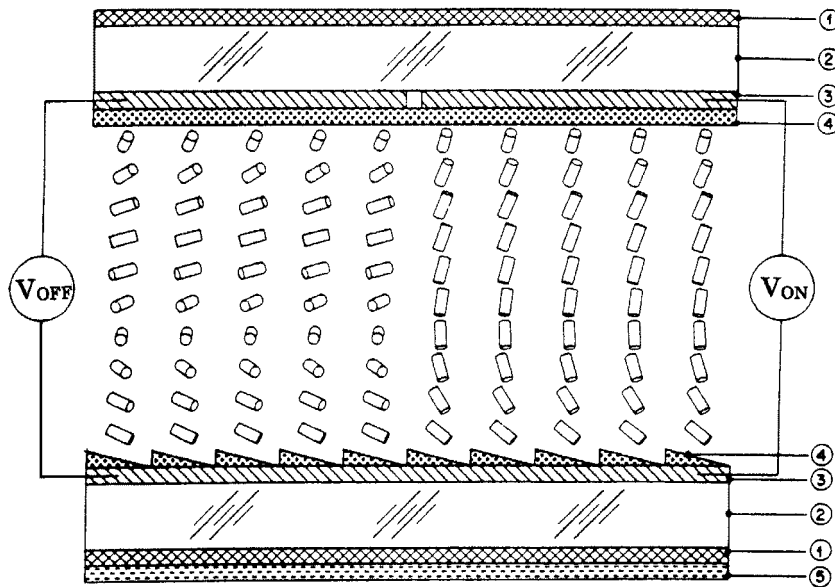

Fig. 43. Schematic view of a reflective STN matrix display with a left-handed twist angle of 270° showing the orientation of the local optic axis with applied select and nonselect rms voltages V_{ON} and V_{OFF} [83]. (1) Polarizer. (2) Glass plate. (3) Transparent electrode. (4) High-pretilt orientation layer. (5) Reflector.

In 1983, Terry Scheffer *et al.* discovered the principle and presented the performance of an LCD that used an electrooptical effect with a much better image quality than a TN display multiplexed at the same high level [82]. Jürgen Nehring and Scheffer referred to this new effect as the supertwisted birefringence effect (SBE) because the layer twist angle was about three times the twist angle of a TN display and the contrast resulted from the interference of the two optical normal modes rather than from the guiding of a single mode [83]. The SBE was later called the STN mode. The fundamental difference in cell construction between the STN display and a conventional TN display are $\sim 270^\circ$ liquid-crystal twist angle [78] (see Fig. 43), high pretilt orientation layers [78], and nonconventional orientation of the polarizers [82]. The 270° twist was achieved with a chiral nematic liquid crystal (nematic liquid crystals doped with cholesteric liquid crystals). In contrast to the 270° guest-host device [78], the STN display contained no pleochroic dyes and used two polarizers.

The discovery of the SBE was triggered by a publication by Berreman and Heffner of Bell Laboratories in 1981 on the 360° bistable twisted cell. It was known that the bistable range of a TN layer is critically dependent upon the total twist angle Φ [80], [84]. This is illustrated by the computer curves in Fig. 44, which show, for various twist angles Φ , the voltage dependence of the director in the midplane of a chiral nematic layer with a 28° pretilt angle at both boundaries. When Φ is decreased, the bistable range (region of negative slope) decreases until it completely disappears, in this case, at 245° , resulting in an infinitely steep slope. Scheffer and Nehring felt that a highly multiplexed display could be made using conventional rms driving waveforms [74] and immediately built a two-pixel test rig. With ON and OFF rms voltages chosen to lie on either side of the bistable range, simulation showed that up to several hundred lines could be multiplexed

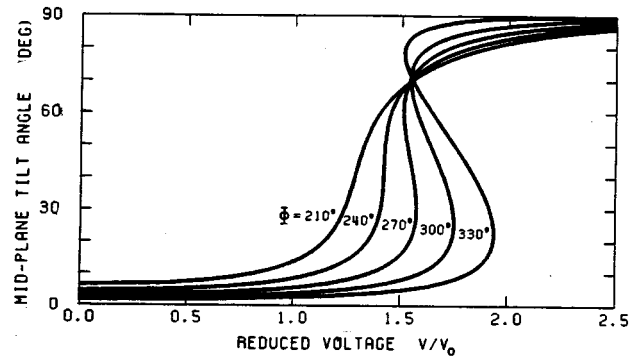

Fig. 44. Theoretical curve of the twist angle of the local optic axis in the layer midplane versus reduced voltage V/V_0 , where V_0 is the threshold voltage of a nontwisted layer with zero pretilt. Thickness/pitch ratio d/p is varied simultaneously with the total twist Φ to maintain the relation $d/p = \Phi/2\pi$ [83].

by adjusting the polarizer and using a layer with the twist angle of 270° .

The purpose of the high pretilt angle was to ensure that only deformations of the type illustrated in Fig. 43 occurred in the display. For layers with low pretilt angles, a topologically inequivalent distortion with 180° less twist was more stable at voltages near the steep part of the electrooptic curve [85]. When a voltage in this range was applied to a low-pretilt matrix display, the lower energy state was observed to form inside disclination loops, which originated at the edges of certain dots and then slowly grew larger. A sufficiently high pretilt angle on the order of 5° or more at both boundaries prevented this unwanted effect and prevented the occurrence of a two-dimensional stripe instability. (Reference [79] refers to the stripe instability as scattering texture.)

They found that cells with a twist angle of about 270° placed between nonconventionally oriented polarizers not only exhibited very wide viewing angles but also possessed

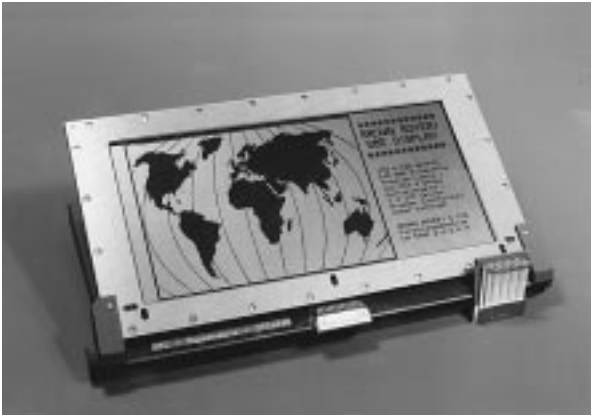

Fig. 45. The first blue-mode reflective STN (SBE) display having 540×270 matrix with $1/135$ duty cycle. Courtesy of ABB, Baden, Switzerland.

contrast ratios much higher than could be obtained with the guest-host effect, provided the birefringence Δn of the liquid crystal had been appropriately chosen. The maximum brightness of the OFF state occurred when the product $\Delta n \cdot d \cdot \cos^2\langle\alpha\rangle$ is on the order of $0.8 \mu\text{m}$, where $\langle\alpha\rangle$ is the average pretilt angle in the OFF state. For a nematic layer with a 270° left-handed twist, a minimum select state brightness was obtained, when the front polarizer was oriented so that the plane of variation of the E vector made approximately a 30° angle with the projection of the director at the front boundary onto the layer and the rear polarizer was at an angle of $\sim 60^\circ$ with respect to the projection of the director at the rear boundary. (Angles are regarded as positive in a clockwise direction when viewing the cell from above.) This nonstandard orientation of the polarizers was required because of the residual twist and retardation of the ON state. The display had a bright yellow birefringence color in the OFF state as a result of the interference of the optical normal modes propagating in the layer. Rotation of one of the polarizers through an angle of 90° resulted in a complementary image of equally good quality to the previous “yellow mode” in which the ON state is colorless and bright and the OFF state is dark blue (“blue mode”).

The voltage range of bistability and the color of the OFF state of the STN display both depended critically upon the thickness of the nematic layer. Therefore, uniform cell spacing was essential for good performance [79]. From both theory and experiment, a 2% increase in layer thickness, e.g., was observed to result in a 1% increase in the operating voltage (i.e., a proportional relationship exists). A thickness variation of this magnitude was acceptable for multiplexing up to several hundred lines and the change in the yellow or blue birefringence colors was scarcely noticeable.

In present-day STN displays, a twist of 240° or 260° is widely used and the corresponding pretilt angle is $4^\circ \sim 5^\circ$ or $6^\circ \sim 8^\circ$.

G. Demonstration of Prototype

The BBC team began constructing displays utilizing the new high multiplex mode. At the 1985 Society for In-

formation Display (SID) Meeting held at Orlando, FL, Scheffer and Nehring demonstrated two panels having aluminum reflectors: one with yellow mode and the other with blue mode (see Fig. 45). Both had a $121.5 \text{ mm} \times 243.0 \text{ mm}$ screen size and a 540×270 matrix with a $1/135$ duty cycle [86]. The audience included a number of engineers who were searching for a highly multiplexable display in the SID meeting. Among them was an engineer from Sharp. The engineer recognized that the contrast of the BBC’s display was excellent; he had not seen such high quality and resolution before.

Nehring later visited various manufactures in Japan including Sharp at Nara on June 14, 1985 and gave a demonstration of the display. The engineers who had been initially suspicious about the report on the SID demonstration were convinced by the quality of the picture demonstrated before them. They quickly decided to use the new STN mode in their panel. The objective was to demonstrate the panel at the October 1985 Japan Electronics Show and they only had three months to prepare it. BBC used vapor deposition for the high-pretit alignment layer and a twist angle of 270° . This gave a high contrast, but it was not a practical production process. Sharp engineers wanted to achieve a balance between contrast and practicality. They decided to use the same rubbing technique (low pretilt angle) commonly used in the production of TN displays. Another problem was the angle of twist. A high contrast was achieved by twisting 270° , but alignment failures occurred. They tried many different degrees of twist and ended up with the compromise of 240° twist. (It had been found that for the low pretilt angle a preferred twist angle was 225° [81].) Some displays appeared completely red and Sharp engineers later found that there was a mistake in the birefringence design. After many trials, they succeeded in constructing a 640×400 matrix display with a $1/200$ duty cycle. They exhibited the panel at the 1985 Japan Electronics Show held at the Intex site in Osaka. Several manufacturers including Sharp, Hitachi and Daini Seiko were demonstrating LCDs based on the same STN mode. Show attendees were impressed and asked whether the demonstrations were really liquid-crystal type displays. The demonstrations were a success. The seed that was sown in Malvern, U.K. and Baden, Switzerland had bloomed in Osaka, Japan.

In 1980, before these events happened, BBC had sold 50% of its LCD manufacturing arm to Philips and the joint company’s name became “Videlec.” In 1984 BBC decided to get out of the liquid-crystal business altogether and sold its share of Videlec to Philips. The liquid-crystal research at BBC ceased in 1985.

H. Materials for STN Mode

Many of the nematic mixtures used for the TN display can also be used for the STN display, but the best performance is achieved with mixtures that have been optimized to satisfy STN specific requirements. Contrary to the materials for multiplexed TN mode, STN mode requires the k_{33}/k_{11} be rather high [81], [87]. The desired steepness of the t/v curve

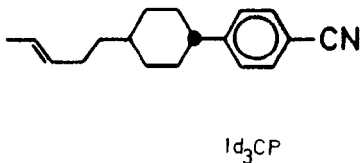

Fig. 46. Odd alkenyl used in STN cells.

can be obtained by further adjusting the twist angle, pretilt angle, and chiral pitch. In order to avoid changes in color with changing temperature the clearing point of the nematic mixture should be at least $30^{\circ}C$ above the highest operating temperature specified. The nematic mixture should possess a low viscosity for fast response.

Hoffmann-La Roche had developed even alkenyl liquid-crystal mixtures for use in simple-matrix TN displays [88]. In 1986, they formulated related mixtures—an odd alkenyl—specifically for use in the STN mode [87] (see Fig. 46). The odd alkenyl exhibited high k_{33}/k_{11} and, thus, was suitable for the STN application. Starting in the 1990s, alkenyl mixtures have been widely used for the STN displays.

I. Color-Compensated STN Displays

The discovery of STN mode gave a great boost to the display industry, which had been looking for a high information content display. In March 1986, Seiko Epson announced it would start selling a product based on the STN mode—a wide-angle view personal word processor [89]. They twisted the liquid crystals by an angle much less than 270° (at that time, it was not possible to twist by the full 270°). They operated the display in a reflective mode with a colored polarizer. As a result, the display had a light green background with bright blue letters. In the same month, Oki Electric Industry introduced a Telecomputer, a combination telephone and computer [90]. Its display, supplied by Sharp, was based on the STN mode and operated with a 180° twist angle in a reflective mode. The display exhibited a light green background with strong blue letters. Later, it became possible to twist the liquid crystals at a 240 or 260° angle. Still, the display was colored and the color varied depending upon the orientation of the polarizers. They chose yellowish green or blue color because displays with those colors gave good contrast and had a pleasing appearance.

The next objective was to achieve a white color. To achieve a full color display, a white background is prerequisite. Then, a mosaic color filter can be applied to the white display. Various approaches had been tried. Back in 1980, Fumiaki Funada and his colleagues at Sharp invented a back-to-back TN display to compensate for the TN's interference coloring [91]. When the requirement of a white display came, they applied the idea to the STN panel; twisting by 240° in the first panel, then untwisting by 240° in the reverse direction in the second panel, thereby the optical properties of the second panel compensate for the optical properties of the first panel. Wada *et al.* of Seiko Epson conceived the same idea in 1986 [92]. The engineers in the Sharp factory, who first resisted trying this because

they believed that the idea was too complicated to implement, were eventually convinced. Again, many difficulties arose. Streaking arising from the rubbing process appeared and they had difficulty in achieving exact 240° twists both in the front and back panels. The distance between the plates was narrow. The tolerance had to be within $\pm 0.5 \mu m$ for a conventional STN panel. In the back-to-back configuration, the tolerance became as small as $\pm 0.05 \mu m$. The first test samples exhibited a Newton ring; colors similar to those observed when a drop of oil is placed on the surface of water. Although the distance between the two panels was kept constant by the use of spacing balls, an atmospheric change caused an abnormality in the spacers whereby the two panels touched at some points. After fixing these problems by improving the spacer material and changing their positions, they were able to demonstrate a paper-white display unit. Since two panels were used, they named this the “double super twisted nematic” (DSTN) mode, while Seiko named it the “neutralized twisted nematic” (NTN) mode. The contrast ratio of a DSTN panel was 3 times that of a STN panel and the viewing angle was 1.6 times larger. Sharp immediately fabricated the first truly white-background product: a DSTN word processor [93]. Soon demand for the DSTN word processor exceeded the demand for the STN word processor.

By using a mosaic color filter on it, the back-to-back display was transformed into a full color display. In 1987, Seiko published a paper on the NTN multicolor display [94] [95] and, in 1988, Sharp and Asahi Glass announced in the SID meeting that they developed the DSTN color displays [96], [97].

The concept of the DSTN had been proved workable. However, a display made of two panels was heavy and its complicated structure made it difficult to manufacture. Seiko suggested that white display could also be realized using a birefringent film replacing the second panel [92]. At that time, the available films were small pieces and the engineers needed a film large enough to match the size of display panel. Nitto Denko Corporation agreed to try to make such film for Sharp. Seiko asked Sumitomo Chemical to manufacture the film. The film was made by stretching a polycarbonate sheet to a constant $50 \mu m$. Constancy of film thickness was an important factor and was required to be $\pm 2.5\%$. The resultant display was a tremendous improvement because they could now achieve a white-color display with only a single panel. This made it suitable for use in portable equipment such as PDA's. Seiko named the mode the “film twist nematic” mode, while Sharp named it the “film super twisted nematic” (FSTN) mode.

The Sharp engineers recognized that when a large size panel was required, a single layer film could not completely compensate for the coloring. Seiko [92] and Sharp [98] invented a structure in which two sheets of film sandwich the STN panel. Sharp called this structure the “triple super twisted nematic” (TSTN) mode.

Nowadays, the STN and DSTN mode are not practically used in the LCD industry; rather, the FSTN and TSTN modes are used. The FSTN display is used mostly in portable equipment such as PDAs and cellular telephones. The TSTN dis-

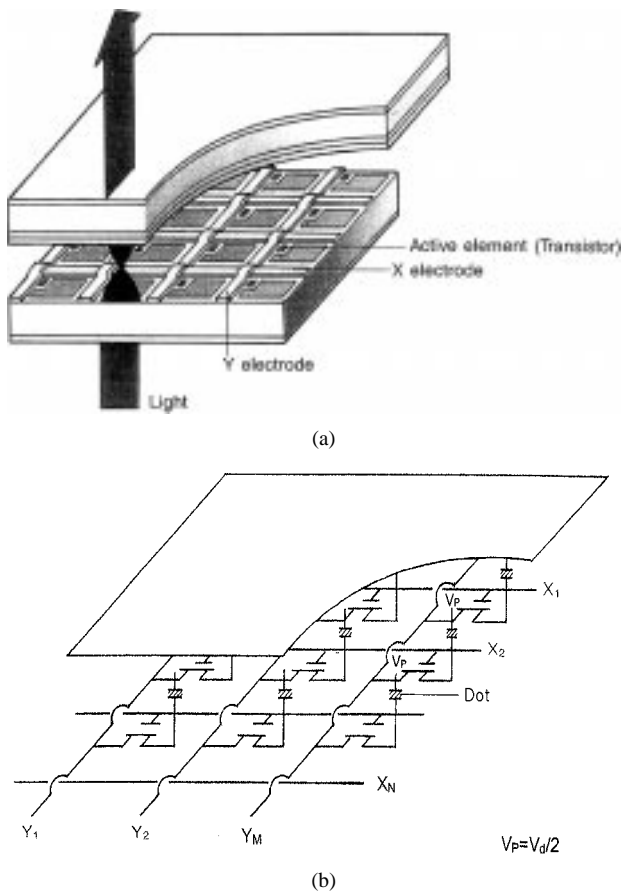

Fig. 47. (a) Structure of AM driving display. (b) Circuit.

play is used mostly in large display equipment such as word processors. When engineers refer to an STN display, they actually mean either an FSTN or TSTN display.

IX. ACTIVE-MATRIX DRIVE—THE METHOD OF OPERATION THAT REALIZED THE WALL-HANGING TELEVISION (DEVELOPED IN THE U.S., THE U.K., AND JAPAN)

During the second half of 1980s, the simple-matrix drive with STN mode was established. The STN mode was used in PDAs, word processors, and early PCs. However, for television applications, a display required capabilities such as gray scale, high resolution, and the ability to display a fast moving picture, which STN could not offer. Going into 1990s, the simple-matrix drive evolved to an AM drive with a TFT array.

A. Active-Matrix Drive

The concept of an AM drive for use in LCDs goes back to 1971 when Bernard Lechner, Frank Marlowe, and others at RCA laboratories proposed the idea of using an array of TFTs to control cells operating in DSM [99]. Fig. 47 shows the operating principle of the AM drive. An active element made of a TFT is placed at a corner of the dot on the inner surface of the bottom plate. Driving lines X_1, X_2, \dots, X_N (called gate lines) carry switching signals and driving lines Y_1, Y_2, \dots, Y_M (called source lines) carry video signals. The TFT acts as a switch. All dots on a gate line are simultaneously turned ON for a period T/N and

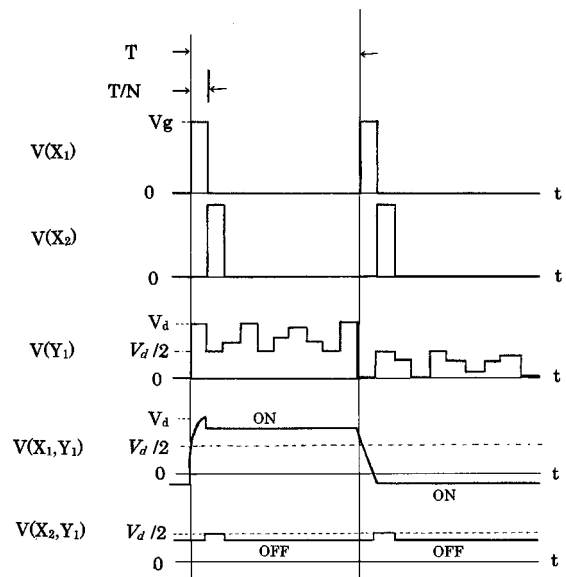

Fig. 48. Waveforms in the AM display [14].

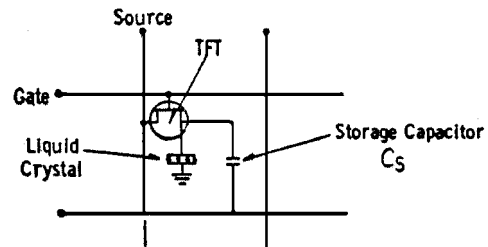

Fig. 49. AM circuit with external storage capacitor [99].

the video information is applied through the source lines. The scheme enables each dot to operate independently from its neighboring dots. Unlike the simple-matrix drive, the charge stored in a liquid-crystal capacitor does not discharge through the source line during a $T(1 - 1/N)$ OFF period, except for leakage through the liquid crystal; thus, the cell can be operated at full swing, which makes the contrast large and viewing angle wide. Fig. 48 exhibits typical waveforms in the AM drive scheme shown in Fig. 47.

The AM drive can afford to use the TN mode where the gradual curve of the t/v characteristic makes a gray scale possible. Unlike the simple-matrix drive, the maximum number of lines N_{\max} is not limited by $\Delta V/V_C$; rather, it is determined by the rise time of the TFT. Unlike the STN panel, the AM panel is no longer subdivided into two panels. So far, N_{\max} as large as 1200 has been realized.

To prevent the charge stored in the liquid-crystal capacitor from escaping, the bulk resistivity ρ_L of the liquid crystal has to be as high as $10^{12} \Omega \cdot \text{cm}$. When the resistivity is high, the absorption of ions at the sandwiching plates may affect the resistivity and it may be difficult to control the uniformity of the display and the repeatability of the cell fabrication. To alleviate the problem, modern liquid-crystal cells use an external capacitor C_S as shown in Fig. 49, which was suggested in 1971 by the RCA team [99], by which the requirement of high resistivity ρ_L can be eased.

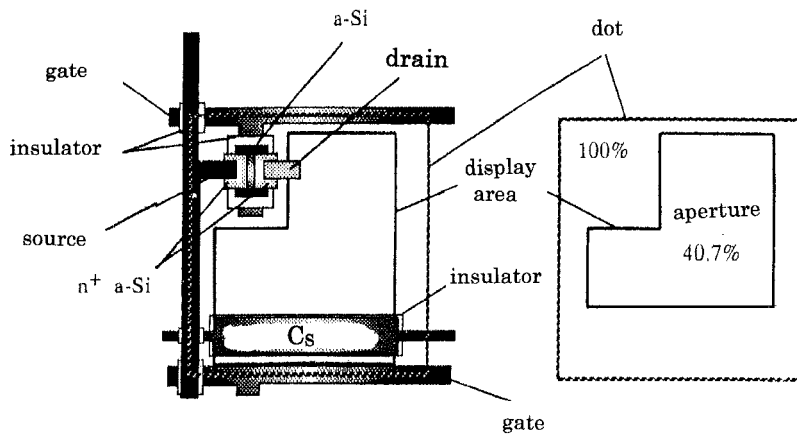

Fig. 50. Top view of a dot in AM display [44].

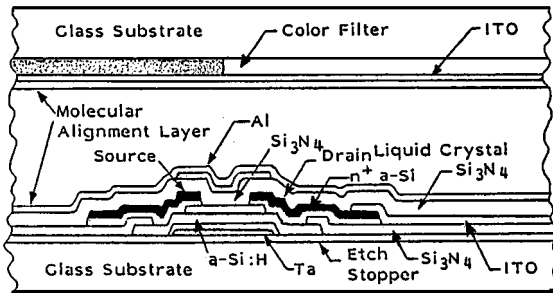

Fig. 51. Cross-section view of amorphous Si TFT cell [100].

Fig. 50 shows the top view of a dot and Fig. 51 shows a cross section view of the TFT for a 3.2-in a-Si display. A filter having red, green, and blue dots is grown on the inner side of the top glass plate. A set of red, green, and blue dots form a “pixel” and represents white color. Light enters from the bottom, passes through the liquid-crystal layer, and exits from the top glass.

B. Early Attempts

The first serious attempt to achieve an AM display was reported in 1972 [101]. Under a series of funding from the U.S. Air Force and the Office of Naval Research, T. Peter Brody and his colleagues of the Westinghouse Electron Tube Division used cadmium selenide as a semiconductor material for the TFT. In 1973, they achieved the first operating AM TFT LCD (still picture) 6-in×6-in having 14 000 dots [102]. Though the results were not perfect by present standards, it is worth mentioning that all the elements of a modern AM TFT display were present. In 1978, Luo *et al.* gave the first public demonstration of a video picture (black and white) [103].

In late 1976, a major portion of the Westinghouse Electron Tube Division was closed and the developers lost their major internal sponsor. With the change of top management at Westinghouse, the liquid-crystal development efforts at Westinghouse ceased.

Reacting to an article on liquid-crystal technologies, Brody, in a letter to *The New York Times* on January 8, 1991, wrote: “Everybody recognizes George H. Heilmeyer as the inventor of LCDs, based on the dynamic scattering

effect. These displays, however, are very distant relatives of the flat-panel television displays being developed in Japan today, which use the field effect, invented by Fergason and a totally different way of addressing and driving the liquid-crystal layer... The Technology that turns the otherwise sluggish and low-performance liquid-crystal layers into color television panels is the AM technology that was born and developed, not in the RCA Laboratories, but in my department at Westinghouse laboratories. I coined the term “active matrix,” by which the technology is now known and wrote the first publications on AM television screens. Heilmeyer would be the first to acknowledge this.”

But like RCA, Westinghouse decided that flat panels were of no interest and dropped the project in 1979—long before the Japanese even entered the field. Brody left Westinghouse because of this decision and in 1981 founded Panelvision, the first company to put AM display products on the market. Panelvision was sold to Litton Industries in 1985 at the behest of its venture capital backers, who decided the small company could not hope to compete with the bigger Japanese companies.

C. Tellurium, Crystal-Silicon, and Poly-Silicon TFTs

The CdSe Westinghouse used for the TFT experiment is toxic and was, thus, not suitable for use in consumer products. Other materials suitable for TFT were sought.

Masataka Matsuura *et al.* of Sharp used tellurium, which had a high mobility, even in thin film form. In 1982, he and his colleagues applied Te-TFT to a segment scheme, then in 1983 developed a 2-in × 2-in 50 × 50 matrix display formed on a glass substrate [104]. However, tellurium TFT had a high OFF current and the ON-to-OFF current ratio did not satisfy the target ratio of 10^6 to one.

Silicon was considered as a strong candidate. Engineers wanted to use silicon because it had served the IC business for the previous 30 years. Its physical behavior and the technology needed to process it were well understood. In 1982, Daini Seikosha Co. used crystalline silicon and formed the transistor arrays and driver circuits on a common silicon substrate. They used the substrate as a bottom reflective plate and chose the guest-host mode as the operation mode



Fig. 52. Crystalline-Si-TFT blue-monochrome guest-host television watch worn by 007—Her Majesty’s Secret Agent. Courtesy of Seiko.

[105]. From this crystalline-silicon LCD technology, Seiko developed a wristwatch television [106] (see Fig. 52). Its display had 152×210 dots. Though this was for a monochrome blue-and-white display, the watch was fashionable and was worn by “007—Her Majesty’s Secret Agent” in the movie “Octopussy.”

It was not possible to grow crystalline silicon in a thin-film form and to fabricate a TFT array on glass and thus crystalline silicon was not suitable for a large display. Poly-silicon and a-Si were other candidates. Though its performance is not as good as that of crystalline silicon, poly-silicon has a rather high mobility and was, thus, considered a possible candidate to form both TFTs and driving circuits on a common substrate. OFF-leakage current and ON current were higher than those of a-Si. In 1983, Shinji Morozumi and his colleagues at Seiko Epson succeeded in demonstrating the first full-color display, a 2.13-in device with a 240×240 resolution [107]. However, poly-silicon had to be processed at a temperature higher than 600°C and, thus, was placed on a quartz substrate rather than on a glass substrate. The use of quartz restricted the size of display to around three inches. (It has now become possible to form poly-silicon TFTs and the driving circuit on a common glass substrate.)

D. Amorphous-Silicon TFT

Amorphous-Si generally yields very low leakage currents and low ON currents. It can be processed at temperatures lower than 600°C and, thus, can be placed on an ordinary glass substrate; this presented the opportunity of going to a large size display. However, because of its low mobility,

display engineers thought that it could not be used for making the TFT liquid-crystal switches. G. L. Le Comber, W. B. Spear, and their colleagues at the University of Dundee in Scotland had been working on a-Si for the purpose of applying it to solar cells. They grew a-Si film on a glass substrate using a glow-discharge technique. The a-Si possessed a property associated with the presence of hydrogen in the plasma and with a particular deposition method. They demonstrated that the a-Si:H could be made into a field-effect transistor (FET). In 1979, they indicated the possibility of using a-Si in a TFT array for LCDs [108], [109].

In 1982, Spear visited Japan and gave a series of lectures. In his presentation at Sharp, he talked about a-Si technology—primarily for the purpose of applying it in solar cells. At the very end of the talk, he added that with a-Si:H he had been able to fabricate an FET. This made the liquid-crystal engineers who had been working on tellurium excited and initiated the work on a-Si TFT’s. Its ratio of ON-to-OFF currents was on the order of 10^6 , thus a-Si was suitable for TFT applications. The Dundee discovery caused the research on a-Si TFT that had been going on at other places to accelerate. The field was soon crowded with major electronics companies and laboratories such as Canon, Fujitsu, French Telecommunication Laboratory, French CNET Laboratory, Toshiba, Hitachi, and Matsushita. In 1982, based on the a-Si technology, Cannon developed a 240×240 dot matrix $96\text{-mm} \times 96\text{-mm}$ display [110]. In 1983, Toshiba developed a $40\text{-mm} \times 60\text{-mm}$ display having 240×220 dots [111]. In 1986, Matsushita demonstrated a 378×240 dots 3-in full-color display [112].

E. Wall-Hanging Television Display

Sharp had been concentrating on tellurium type displays and only in 1985 did it seriously get involved in the a-Si-type display. In 1986, Washizuka became Division General Manager of the newly formed Liquid Crystal Division. Two lucky things were happening. Sharp had long been working on a-Si for solar cells. With the end of the oil crisis, they shifted the engineers who had been working on solar cells to the LCD area. The other was that Sharp was not involved with the production of CRTs; therefore, it had been able to focus on the technology and business of LCDs.

In July 1987, the state of the art for an LCD was three in [112]. The size of the glass substrate Sharp used was $320\text{ mm} \times 400\text{ mm}$ and they were fabricating nine 3-in displays on one substrate. Competition was fierce and the process was not profitable. As a next step, engineers had proposed going to 4-in, then 5-in and 6-in displays. Washizuka refused all those proposals. He was looking for a quantum jump and asked a television engineer what would be the minimum size for a display for home-use televisions. The reply came back: “Fourteen inches.” Hiroshi Take and Kozo Yano examined the glass substrate and the process Sharp was using in the factory. The glass substrate could just make the required 14-in size. They came back with a proposal to fabricate a 14-in display to which Washizuka agreed.

One of the team members recalls the events that happened after that. Washizuka insisted on using only existing manufacturing equipment. This meant they now had to use the stepper that had been used for the 3-in panels for the exposure of a 14-in panel. They subdivided the panels into nine areas and used the stepper nine times. The major problem was the length of the conduction lines. They knew the statistical value for line breaks from their experience in manufacturing 3-in panels. By extending the statistical value, they predicted that the 14-in panel was not going to make it, using existing design rules. They brainstormed and came up with the idea of subdividing a dot into four identical subdots. The subdots were driven by two source lines having identical signals and with two gate lines also having identical signals. The source lines were driven from the two ends of the panel; so were the gate lines. With this four-fold redundancy and two-end supply scheme, even if there was a break in one line, the signal could be propagated without interruption. By using four identical subdots, a defect in one subdot was not noticeable when a moving picture was displayed. Three dots were arranged in a triangular shape—each having a red, green, and blue filter, thus, forming one pixel. The pixel had 12 subdots and the panel was made of 1284×960 subdots.

Except for the conduction line, they did not expect too much of a problem. The production facility, however, was in almost full use for manufacturing the 3-in panels. Sano quietly pushed a panel through the manufacturing line whenever he found a short period of time when the line was not being used for production. The experiment was a so called “Friday afternoon” experiment. Having been started in August 1987, the process of pushing the panel through the production line was finally finished in February 1988. To the surprise of all the people involved, the first 14-in panels looked okay when examined by the naked eye. They secured four good panels.

The next task was to operate the panel with appropriate peripheral circuits. Take recalls that a module group had prepared an application-specific integrated-circuit controller. As for the drivers, they did not have time and money to design a new one, so they used the drivers for the 4-in display. Even the source and gate lines were driven from both ends, he had to operate the driver at three times its specification. The 4-in source driver was designed to operate at approximately 6.5 MHz. Instead, it was operated at 13 MHz. The driver overheated and required a fan cooler. In April 1988, they tested the panel. The first trial exhibited only a black picture. Examining the problems and fixing them, they could demonstrate a still picture, but the size in the horizontal direction was one-half the full panel size, which meant that the source driver clock was operating at only half the required frequency. By brute force, they gradually increased the voltage of the logic circuit. Suddenly, a full-size moving picture appeared, but the picture showed a long tail when tracing a fast moving object. They needed a new driving circuit. Washizuka went to the IC Group and asked them to fabricate a new LSI. With the new LSI, the engineers succeeded in demonstrating the 14-in full-color full-motion display. Subsequently, the panel was shown to the president. The panel was too good to be true. His first reaction was that



Fig. 53. Washizuka and 14-in full-color full-motion display. (Courtesy of Sharp.)

Washizuka was fooling him with a phony set up; it was only sometime later that he realized to his surprise it was the real thing.

On June 24, 1988, Sharp announced the 14-in TFT color LCD unit. [113] (see Fig. 53), followed by the presentation of [114]. The display was 27-mm thick, including a back light, approximately 1/13 of a conventional CRT display, and its weight was 1.8 kg, approximately 1/4 of a CRT display. Most importantly, the display size of 14 in was the minimum required for a television receiver serving ordinary households and the display could be mounted on a wall. The announcement sent a message to engineers and managers that LCDs, which had been serving the niche market for portable equipment such as pocket calculators and PDAs, now could serve the market for home appliances such as television receivers. The LCD could now eventually replace CRTs. Electronics giants such as Toshiba, IBM, and NEC, which had been performing only research into LCDs, but were not involved in the business of manufacturing them, now joined the burgeoning liquid-crystal industry. The 14-in display development vaulted the LCD industry to major-league status. A true LCD industry was born.

In 1991, Magohiro Aramoto of Sharp’s Audio-Video Group introduced the first wall-hanging-television product, the “Liquid Crystal Museum” [115] (see Fig. 54).

Recalling the events, Washizuka said that he had been fortunate because his factory had been using a 320-mm \times 400-mm glass substrate, whereas others were using smaller glass substrates. The development of the 14-in display may have been a Friday afternoon experiment, but if the factory had not been operating with the 320-mm \times 400-mm glass substrate, he could not have even tried it. Heilmeier’s dream of a wall-hanging television in 1964 finally became a reality after a quarter of a century. In *The Wall Street Journal* [17], Heilmeier remarked: “I think you need to give the credit to the people who persevered and worked on LCDs for 25 years. I don’t spend too much time wringing my hands about it, but I have a lot of satisfaction knowing we had the same vision in the 1960s.”



Fig. 54. The first wall-hanging televisions. (Courtesy of Sharp.)

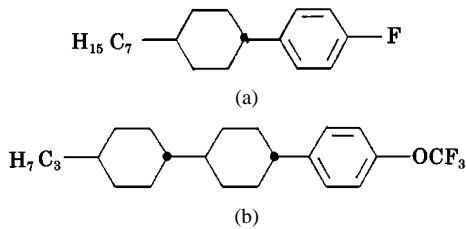

Fig. 55. Fluorinated liquid crystals for use in AM TFT cells. (a) 1-fluoro-4-(trans-4-n-heptyl-cyclohexyl)-benzene. (b) 1-trifluoromethoxy-[trans-4-(trans-4-n-propyl-cyclohexyl)-cyclohexyl]-benzene.

F. Material for the Active-Matrix Drive

For the purpose of obtaining a wide gray scale, the TN mode is used in the AM drive. Liquid-crystal materials for use in the AM addressing scheme are required to have a gradual t/v curve and, therefore, low k_{33}/k_{11} . They also need small V_C , low viscosity [(5) says that small V_C requires high $\Delta\epsilon$, in turn, the high $\Delta\epsilon$ has been found to give rise to high viscosity], and high resistivity.

The LCD industry first went back to the phenyl cyclohexane that had been used in the TN-mode segment scheme. Considering the influence of elastic, dielectric, and optic properties on the bulk resistivity of the liquid crystals, mixtures specifically for use in the AM driving scheme had been developed [116]. A key component of the mixture used in the 14-in display was trans-4-(trans-4-n-propyl-cyclohexyl)-cyclohexylbenzotrile. The PCH had a CN radical and its resistivity was not as high as the resistivity an AM drive required.

In 1990, Merck developed a family of materials having fluoride radicals [117] (see Fig. 55) and, thus, exhibited high resistivity. As compared with the cyano substituted compounds, the viscosity had been significantly reduced, not only at 20°C, but also at subzero temperatures. The optical anisotropy Δn was reduced to the range of 0.085–0.105. This reduction made the mixture operate at the first transmission minimum (see Section V-D), leading to a large viewing angle. The materials also exhibited relatively small dielectric anisotropy, nevertheless, due to the low values of the elastic constants, the material realized thresholds in the range of 1.8–2.0 V. Currently, liquid crystals used in AM displays are largely of the terminally fluorinated type.

X. CONCLUSION

The development of liquid-crystal devices have been reviewed spanning the period of 1962 through 1991. I have tried to concentrate on events, not people, but we should not forget the people who made these events happen.

A. Chronology

Table 3 lists key events that happened during the 30 years covered by this paper. The events are listed by the year of patent application (priority data), technical publication, press release, or product catalog. I have listed events that are available only in the public domain. The far-left column lists new modes and physical mechanisms, starting from the Williams domain and followed by guest-host mode and DSM. The next column lists materials developed for use in the new operation modes. Publication was not necessarily the purpose of the material developments; therefore, the date of their publications tends to be delayed from the actual date of invention. The next column lists prototypes developed based on the new mode of operation. The far-right column lists commercial products successfully offered to the market. Generally speaking, the events flowed from new mode of operation to new materials, then prototypes, and finally commercial products.

B. U.S., Japan, and Europe

The history of liquid-crystal developments has been the history of competition among institutions and companies scattered over three industrialized regions: 1) the U.S.; 2) Europe; and 3) Japan. At the same time, these competitors assisted each other. The success of liquid-crystal devices could not have been achieved without such competition. As for the regions' contributions, the U.S. contributed to all the early attempts: particularly, RCA Laboratories to the Williams domain, guest-host mode, DSM, active-matrix TFT drive, Schiff's bases, the digital clock and others to the analysis of limitation of simple-matrix drive and digital watches. Europe contributed to the developments of TN mode, the transition minimum, amorphous-Si FET, the concept of 270° twist, STN mode, azoxy compounds, esters, cyanobiphenyls, phenyl cyclohexane, the alkenyl family, terminally fluorinated compounds, and the STN panel. Japan contributed to the optimization of the simple-matrix drive, back-to-back panel, film STN, the Mirror Clock, NTN color display, 14-in a-Si-TFT display, pocket calculator, digital watches, crystalline-Si-FET television watch, poly-Si-TFT full-color television, STN word processor and telecomputer, DSTN word processor, and wall-hanging television. We now recognize that America's strength was in its speed in creating new ideas and then demonstrating their feasibility. Europe's strength was in fundamental science and synthesizing basic materials. Japan's strength was in perfecting the implementation and moving it to mass production.

C. CRT was the Key

As seen in Section III, RCA rejected the idea of LCDs because they considered the liquid crystal a threat to their existing CRT business rather than an opportunity. For RCA,

Table 3
Key Events in 1962 Through 1991 That Led to the Final Goal of the Wall-Hanging Television

| Year | Mode/ Physical Mechanism | Materials | Prototypes | Commercial Products |
|------|--|----------------------------------|--|---|
| 1962 | Williams Domain | | | |
| 1964 | ·Guest-Host (GH) ·Dynamic Scattering (DSM) | | | |
| 1967 | | Schiff's bases | Digital Clock (DSM, Schiff's bases) | |
| 1968 | Announcement of DSM | Cyano Schiff's bases | | |
| 1969 | | MBBA | | |
| 1970 | Twisted Nematic (TN) by Schadt and Helfrich | Azoxy Compounds | | |
| 1971 | ·TN by Fergason ·TFT Array for Matrix drive— conceptual | | Digital Watch (DSM Schiff's bases) | |
| 1972 | | ·Cyano Esters ·Cyanobiphenyls | | |
| 1973 | Limitation of Simple Matrix by Kawakami | Cyclohexane Esters | Active Matrix Panel (TN, CdSe-TFT) | ·Pocket Calculator (DSM, MBBA) ·Digital Watch (TN, azoxy, yellow) |
| 1974 | ·Transition Minimums in TN Mode ·Limitation of Simple Matrix by Alt and Pleshko | | | |
| 1975 | | | Mirror Clock (DSM, MBBA) | |
| 1976 | | | | ·Pocket Calculator (TN, Cyanobiphenyl, light gray) ·Digital Watch (TN, Cyanobiphenyl, white) |
| 1977 | | Phenyl Cyclohexanes (PCH) | | |
| 1979 | ·Amorphous-Si FET | | | |
| 1980 | ·Back-to-Back Panel | | | |
| 1981 | ·Wide Angle at 1 st Minimum | | | |
| 1982 | 270-degree Twist | | Amorphous-Si TFT, Active-Matrix Panel | Crystalline-Si FET, Watch TV (GH, AM, blue-Monochrome,) |
| 1983 | Super Twist Nematic (STN) | | | Poly-Si TFT, 2.13" TV (TN, AM, full-color) |
| 1985 | | Alkenyls | STN Panels (yellow or blue) | |
| 1986 | Filmed STN | | | ·STN Word Processor (green) ·STN Telecomputer (green) |
| 1987 | | | NTN Color Panel | DSTN Word Processor (white) |
| 1988 | | | 14" TV Panel (TN, AM, a-Si TFT, full-color, full-motion) | Film Twist Nematic Word Processor (white) |
| 1990 | | Terminally Fluorinated Compounds | | |
| 1991 | | | | Television Hanging on the Wall (8.6" TN, AM, a-Si TFT, full-color, full-motion) |

the history of liquid crystals was the history of key discoveries and inventions and, at the same time, the history of lost business opportunities. Beside many early inventions, Helfrich is believed to have conceived the TN mode when he was with RCA Laboratories, Lechner conceived the idea of using a TFT array in the matrix scheme, and Sussman discovered the cholesteric liquid crystal to correct the reverse twist. All three ideas are currently in use throughout the LCD industry. RCA never capitalized on them by making products.

In the U.K., the MoD launched its liquid-crystal research because the U.K. was paying a greater royalty fee on shadow-mask color TV tubes than they had paid for the

development of Concorde. This research bloomed in the first commercially usable liquid crystals—cyanobiphenyls.

When the LCD was invented, the electronic giants that owned the CRT business did not participate in the LCD business. Sharp and Seiko were not involved in the CRT business; for them, liquid crystal was an opportunity. Originally, the LCD industry served a niche market for portable electronic equipment such as pocket calculators and digital watches. They nursed the liquid-crystal industry from its infancy all the way to adulthood. As Asada said, Sharp was fortunate because they had both divisions that made LCDs and those that used LCDs. Therefore, they could find products that matched

the LCD technology at each stage of its technical advancement and they were able to justify the investment. The companies that had not participated in the CRT business instead had gone into the LCD business and later profited. The companies that had owned the CRT business entered the LCD business only after the 14-in full-color full-motion display was demonstrated in 1988.

The members of the LCD industry are now in the major leagues and the industry has caught up to the giant CRT industry in the year 2000, when its market value was 22.6 billion dollars [118]. It is expected to reach the 40 billion dollar mark by the year 2006.

D. Missing Hand-Waving Argument

Liquid-crystal devices make use of the anisotropy and low elasticity of nematic liquid crystals. Because of birefringence, liquid crystal changes the state of polarization of light or the direction of linear polarization of light and because of low elasticity and dielectric anisotropy, liquid crystals are easily reoriented, realigned, or deformed by applying electrical fields, heat, and/or mechanical stress.

I was trained as a semiconductor physicist. One thing I learned in graduate school at Berkeley was the "hand-waving argument." After going through theoretical equations, my professor sketched on the black board the mechanism of the physical phenomenon, taking a matter of minutes and made us visualize the phenomenon. We have seen that behaviors of nematic liquid crystals are now well recognized by LCD engineers and are utilized throughout the industry. For example, liquid-crystal molecules lie on a polyimide surface along the rubbing direction with pretilt, the angle of which is determined by the composition of the polyimide; nematic liquid crystals sandwiched by cross grooved plates form a 90° twist, a linearly polarized light rotates its direction of polarization along the helical twist when the light enters at a right angles of the sandwiching plates, an ac field applied perpendicular to the director changes the director direction of positive nematic molecules to the field direction, but without the alternating field causing resonance in the director, and a small k_{33}/k_{11} is desired for TN mode in the AM TFT scheme, whereas a large k_{33}/k_{11} is desired for the STN mode. I asked liquid-crystal experts to give a hand-waving argument about those phenomena. Their answers were that the only way to understand the phenomena is to go rigorously through the theoretical equations, which might take a couple of hours. In semiconductor physics study, we were intrigued by hand-waving explanations. I believe that grasping a concept through hand-waving arguments and visualizing the physical mechanism, not merely understanding through equations, often leads to the discovery of new physical phenomenon and, thus, the invention of new devices. Theory through equations comes later. Rather complicated liquid-crystal behaviors caused by birefringence and behavioral change caused by external fields have given difficulty to the experts who were asked to explain the phenomena through a hand waving argument. Nowadays, simulations by computers have become so widespread that the researcher may take the result as is and might not try to visualize the physical mechanism. One

researcher said that during the 1970s and 1980s, nematic liquid crystals were thoroughly investigated and that all possible modes of operation have been discovered. Others did not disagree with my statement that we still may have room for discovering new phenomena and inventing new devices. What is certain in the school of liquid-crystal study is that we are still missing hand-waving explanations of the mechanisms of those physical phenomena.

ACKNOWLEDGMENT

The author would like to thank M. Ishii for his continued encouragement, who embodies the living history of LCD designs and manufacturing, encompassing the DSM, guest-host mode, TN mode, STN mode, AM drive, and plasma-addressed liquid-crystal scheme for over 25 years. This paper could not have been completed without his opinions and suggestions. The author would also like to thank Y. Ishii, T. Scheffer, Prof. P. Raynes, and Prof. A. Sasaki for their explanations on the physical mechanisms of liquid-crystal devices and H. Kuwagaki and H. Plach for their description on material for used in particular operation modes. Finally, the author would like to thank all the researchers and developers around the world with whom he interviewed and communicated and whose dialogs enabled him to write this paper.

REFERENCES

- [1] F. Reinitzer, "Beiträge zur Kenntniss des Cholesterins," *Wiener Monatschr. Für Chem.*, vol. 9, pp. 421–441, 1888.
- [2] O. Lehmann, "Über fließende Krystalle," *Z. Phys. Chem.*, vol. 4, pp. 462–472, 1889.
- [3] G. W. Gray, *Liquid Crystals and Some Future Prospect for Their Applications*. Tokyo, Japan: Engineering Academy of Japan, 1995.
- [4] S. Matsumoto and I. Kadota, *Liquid Crystals—Fundamentals and Applications*. Kogyochosha-kai, Tokyo, Japan, 1991.
- [5] G. Friedel, *Annu. Physique*, vol. 18, p. 273, 1922.
- [6] J. L. Ferguson, "Liquid crystals," *Sci. Amer.*, pp. 77–85, ug. 1964.
- [7] R. Williams, "Electro-Optical Elements Utilizing an Organic Nematic Compound," U.S. Patent 3 322 485, filed Nov. 9, 1962, issued May 30, 1967.
- [8] ———, "Domains in liquid crystals," *J. Phys. Chem.*, vol. 39, pp. 382–388, July 1963.
- [9] G. H. Heilmeyer, "Liquid crystal displays: An experiment in interdisciplinary research that worked," *IEEE Trans. Electron Devices*, vol. ED-23, July 1976.
- [10] G. H. Heilmeyer and L. A. Zanoni, "Guest-host interactions in nematic liquid crystals. A new electro-optic effect," *Appl. Phys. Lett.*, vol. 13, no. 3, pp. 91–92, 1968.
- [11] G. H. Heilmeyer, L. A. Zanoni, and L. A. Barton, "Dynamic scattering: A new electrooptic effect in certain classes of nematic liquid crystals," *Proc. IEEE*, vol. 56, pp. 1162–1171, July 1968.
- [12] E. F. Carr, "Influence of electric fields on the molecular alignment in the liquid crystal p-(anisalamino)-phenylacetate," *Mol. Cryst. Liq. Cryst.*, vol. 7, pp. 253–268, 1969.
- [13] W. Helfrich, "Conduction-induced alignment of nematic liquid crystals: Basic model and stability considerations," *J. Chem. Phys.*, vol. 51, no. 9, p. 4092, Nov. 1969.
- [14] A. Sasaki and S. Naemura, Eds., *Liquid Crystal Displays*. Tokyo, Japan: Kogyochosakai, 1993.
- [15] J. E. Goldmacher and J. A. Castellano, "Electro-optical compositions and devices," U.S. Patent 3 540 796, filed Mar. 31, 1967, issued Nov. 17, 1970.
- [16] "RCA announces breakthrough in liquid crystal field; demonstrates thin-screen displays of print, pictures, moving images," presented at the RCA Press Conf., New York, May 28, 1968.
- [17] "George Heilmeyer. The liquid crystal display," *Wall Street J.*, May 24, 1993.
- [18] H. Kelker and B. Scheurle, "Eine flüssig-kristalline (nematische) phase mit besonders niedrigen Erstarrungspunkt," *Angew. Chem.*, vol. 81, no. 22, pp. 903–904, 1969.

- [19] P. Weimer, "Switching circuits," U.S. Patent 3 191 061, filed May 1962, issued June 22, 1965.
- [20] Y. Suzuki, M. Hirasawa, and K. Odagawa, "Clocked CMOS calculator circuitry," in *Proc. Int. Solid State Circuit Conf.*, 1973, pp. 58–59.
- [21] "The world-first computer on substrate; operates for 100 hours with a single AA-size dry battery," Sharp Corp. News Release, May 15, 1973.
- [22] S. Mito and T. Wada, "Application of liquid crystal to COS (calculator on substrate) system electronic calculator," in *Proc. 5th Int. Liquid Crystal Conf.*, 1974, pp. 247–248.
- [23] W. Helfrich and M. Schadt, "Optical device," Swiss Patent 532261, filed Dec. 4, 1970, issued Feb. 15, 1972.
- [24] M. Schadt and W. Helfrich, "Voltage-dependent optical activity of a twisted nematic liquid crystal," *Appl. Phys. Lett.*, vol. 18, no. 4, pp. 127–128, Feb. 1971.
- [25] H. Zocher, *Physik. Chem.*, vol. 132, p. 295, 1928.
- [26] C. R. Chatelain, *Acad. Sci.*, vol. 213, p. 875, 1941.
- [27] F. M. Leslie, "Distortion of orientation patterns in liquid crystals by a magnetic field," in *Proc. 3rd Int. Liquid Crystal Conf.*, Berlin, Germany, Aug. 1970, p. 104.
- [28] C. Mauguin, *Bull. Soc. Franc. Mineral.*, vol. 34, pp. 71–117, 1911.
- [29] H. de Vries, *Acta Cryst.*, vol. 4, p. 219, 1951.
- [30] J. F. Dryer, "A liquid crystal device for rotating of polarized light," in *Proc. 3rd Int. Liquid Crystal Conf.*, Berlin, Germany, Aug. 1970, p. 25.
- [31] G. H. Heilmeyer, L. A. Zanoni, and J. E. Goldmacher, *Liquid Crystals and Ordered Fluids*, J. F. Johnson and R. S. Porter, Eds. New York: Plenum, 1970.
- [32] J. A. Castellano, "Electro-optic light modulator," U.S. Patent 3 597 044, filed Sept. 3, 1968, Aug. 3, 1971.
- [33] A. Boller, H. Scherrer, M. Schadt, and P. Wild, "Low electrooptic threshold in new liquid crystals," *Proc. IEEE*, vol. 60, pp. 1002–1003, Aug. 1972.
- [34] S. L. Arora, J. L. Ferguson, and A. Saupe, "Two liquid crystal phases with nematic morphology in laterally substituted phenylenediamine derivatives," in *Proc. 2nd Int. Liquid Crystal Conf.*, Aug. 1968, pp. 563–577.
- [35] J. L. Ferguson, T. R. Taylor, and T. B. Harsch, "Liquid crystals and their applications," *electro technol.*, pp. 41–50, Jan. 1970.
- [36] J. L. Ferguson, "Display devices utilizing liquid crystal light modulation," U.S. Patent 3 731 986, filed Apr. 22, 1971, issued May 8, 1973.
- [37] —, "Liquid-crystal non-linear light modulators using electric and magnetic fields," U.S. Patent 3 918 796, filed Jan. 24, 1973, issued Nov. 11, 1975.
- [38] J. L. Ferguson and T. B. Harsch, "Reflective system for liquid crystal displays," U.S. Patent 3 881 809, filed May 25, 1973, issued May 6, 1975.
- [39] J. L. Ferguson and D. E. Werth, "Liquid crystal display assembly," U.S. Patent 3 963 324, filed Sept. 10, 1973, issued June 15, 1976.
- [40] J. L. Ferguson, "Gasket for liquid crystal light shutters," U.S. Patent 3 853 392, filed Sept. 13, 1973, Dec. 10, 1974.
- [41] —, "Liquid-crystal mixtures for use in liquid-crystal displays," U.S. Patent 3 960 749, filed Jan. 23, 1974, issued June 1, 1976.
- [42] C. H. Gooch and H. A. Tarry, "Optical characteristics of twisted nematic liquid-crystal films," *Electron. Lett.*, vol. 10, no. 1, pp. 2–3, Jan. 1974.
- [43] —, "The optical properties of twisted nematic liquid crystal structures with twist angle equal or less than 90°," *J. Phys. D. Appl. Phys.*, vol. 8, pp. 1575–1584, 1975.
- [44] T. Yamazaki, H. Kawakami, and H. Hori, *Color TFT Liquid Crystal Displays*. Tokyo, Japan: SEMI, 1994.
- [45] T. J. Scheffer, "Supertwisted-nematic LCDs," in *Society for Information Display Seminar Lecture Notes*, vol. M-12, 2000.
- [46] L. Pohl, G. Weber, R. Eidenschink, G. Baur, and W. Fehrenbach, *Appl. Phys. Lett.*, vol. 38, no. 7, pp. 497–499, Apr. 1981.
- [47] B. W. Berreman, "Solid surface shape and the alignment of an adjacent nematic liquid crystal," *Phys. Rev. Lett.*, vol. 28, no. 26, pp. 1683–1686, 1972.
- [48] E. S. Lee, Y. Saito, and T. Uchida, "Detailed morphology of rubbed alignment layers and surface anchoring of liquid crystals," in *Proc. 12th Int. Display Research Conf.*, Hiroshima, Japan, Oct. 1992, pp. 595–598.
- [49] S. Ishihara, H. Wakemoto, K. Nakazima, and Y. Matsuo, "The effect of rubbed polymer films on the liquid crystal alignment," *Liq. Cryst.*, vol. 4, no. 6, pp. 669–675, 1989.
- [50] S. Ishihara, "Research on the alignment control of nematic liquid crystals," Ph.D. dissertation, Osaka Prefecture Univ., Osaka, Japan, 2000.
- [51] Y. Ishii, private communication, 2000.
- [52] H. J. Deutscher, W. Weissflog, D. Demus, and G. Petzl, "Kristallin-Flüssige Nematische Verbindungen," German Patent 86 269, filed June 15, 1970, issued Dec. 5, 1971.
- [53] H. Kelker, B. Scheurle, H. Hatz, and W. Bartsch, "Liquid crystalline phase having particularly low freezing points," *Angew. Chem. Int. Ed.*, vol. 9, no. 12, pp. 962–963, 1970.
- [54] R. Steinstrasser and L. Pohl, "Nematische systeme IV: Niedrig schmelzende p-Alkyl-p'-Alkoxy- und p-Alkyl-p'-Alkoxy-Azoxybenzole," *Tetrahedron Lett.*, no. 22, pp. 1921–1924, 1971.
- [55] E. P. Raynes, "Twisted nematic liquid-crystal electro-optic devices with areas of reverse twist," *Electron. Lett.*, vol. 9, no. 5, Mar. 1973.
- [56] A. Sussman, "Electro-optic liquid crystal devices: Principles and applications," *IEEE Trans. Parts, Hybrids, Packaging*, vol. PHP-8, pp. 24–37, Dec. 1972.
- [57] E. P. Raynes, "Improved constant uniformity in twisted nematic liquid-crystal electro optic display devices," *Electron. Lett.*, vol. 10, no. 9, May 1974.
- [58] —, "Liquid crystal devices," U.K. Patent 1 472 247, filed Feb. 21, 1974, issued May 4, 1977.
- [59] —, "Optically active additives in twisted nematic devices," *Rev. Phys. Appl.*, vol. 10, pp. 117–120, May 1975.
- [60] G. W. Gray, K. J. Harrison, and J. A. Nash, "New family of nematic liquid crystals for displays," *Electron. Lett.*, vol. 9, no. 6, pp. 130–131, Feb. 1973.
- [61] A. Ashford, J. Constant, J. Kirton, and E. P. Raynes, "Electro-optic performance of a new room-temperature nematic liquid crystal," *Electron. Lett.*, vol. 9, no. 5, pp. 118–120, Mar. 1973.
- [62] D. Hume, P. Raynes, and K. J. Harrison, "Eutectic mixtures of nematic 4'-substituted 4-cyanobiphenyls," *J. Chem. Soc. Chem. Commun.*, pp. 98–98, 1974.
- [63] "Ultra thin 7 mm pocket calculator EL-8125 and EL-8025 (light gray background and high contrast black numerals)," Sharp Corp. News Release, Nov. 11, 1976.
- [64] Seiko digital watch catalog, Nov. 1976.
- [65] H. J. Deutscher, F. Kuschel, H. Schubert, and D. Demus, "Nematische Flüssig-Kristalline Substanzen," German Patent 105 701, filed July 2, 1973, issued May 5, 1974.
- [66] V. R. Eidenschink, D. Erdman, J. Krause, and L. Pohl, "Substituted phenylcyclohexanes—A new class of liquid-crystalline compounds," *Angew. Chem. English Edition*, vol. 16, no. 2, p. 100, 1977.
- [67] L. Pohl, R. Eidenschink, G. Krause, and D. Erdmann, "Physical properties of nematic phenylcyclohexanes, a new class of low melting liquid crystals with positive dielectric anisotropy," *Phys. Lett.*, vol. 60A, no. 5, pp. 421–423, Mar. 1977.
- [68] "Orient magic clock; Time jumps out of the mirror," Orient Corporation News Release, 1975.
- [69] S. Shimura, "Electronics past, no. 15, liquid crystal displays," *Mu-Alpha*, pp. 104–108, Autumn 1990.
- [70] A. Sasaki, Ed., *Liquid Crystal Bases and Applications*. Kyoto, Japan: Ohm, 1979.
- [71] —, private communication, 2000.
- [72] "Quartz oscillator digital wrist watch (liquid crystal display) seiko quartz LC V.F.A.," Seiko News Release, Sept. 1973.
- [73] H. Kawakami, "Method of driving liquid crystal matrix display device," Priority Data Oct. 19, 1973; U.S. Patent 3 976 362, Oct. 15, 1974.
- [74] P. M. Alt and P. Pleshko, "Scanning limitations of liquid-crystal displays," *IEEE Trans. Electron Devices*, vol. ED-21, pp. 146–155, Feb. 1974.
- [75] D. W. Berreman, "Optics in smoothly varying anisotropic planar structures: Application to liquid-crystal twist cells," *J. Opt. Soc. Amer.*, vol. 63, no. 11, pp. 1374–1380, 1973.
- [76] M. Schadt and P. R. Gerber, "Class specific physical properties of liquid crystals and correlations with molecular structure and static electrooptical performance in twisted cells," *Z. Naturforsch.*, vol. 37a, pp. 165–178, 1982.
- [77] L. Pohl, B. Scheuble, and G. Weber, "Multiplexible liquid crystalline broad range systems," *Mol. Cryst. Liq. Cryst.*, vol. 97, pp. 277–286, 1983.
- [78] C. M. Waters and E. P. Raynes, "Liquid crystal devices," Priority Data June 29, 1962; U.K. Patent 2 123 163, Dec. 18, 1985.
- [79] C. M. Waters, V. Brimmell, and E. P. Raynes, "Highly multiplexable dyed liquid crystal displays," in *Proc. 3rd Int. Display Conf.*, Kobe, Japan, 1983, pp. 396–399.
- [80] —, "Highly multiplexable dyed LCDs," *Proc. SID*, vol. 25, no. 4, pp. 261–264, 1984.

- [81] C. M. Waters, E. P. Raynes, and V. Brimmell, "Design of highly multiplexed liquid crystal dye displays," *Mol. Cryst. Liq. Cryst.*, vol. 123, pp. 303–319, 1985.
- [82] H. Amstutz, D. Heimgartner, M. Kaufmann, and T. J. Scheffer, "Liquid crystal display," Foreign Application Priority Data July 12, 1983 (Switzerland); U.S. Patent 4 634 229, Jan. 6, 1987.
- [83] T. J. Scheffer and J. Nehring, "A new, highly multiplexable liquid crystal display," *Appl. Phys. Lett.*, vol. 48, no. 10, pp. 1021–1023, Nov. 1984.
- [84] T. J. Scheffer, "Liquid crystal display with high multiplex rate and wide viewing angle," in *Proc. 3rd. Int. Display Res. Conf.*, Kobe, Japan, 1983, p. 400.
- [85] D. W. Berreman, *Philos. Trans. R. Soc. London*, vol. A 309, pp. 203–203, 1983.
- [86] T. J. Scheffer, J. Nehring, M. Kaufmann, H. Amstutz, D. Heimgartner, and P. Eglin, "24 × 80 character LCD panel using the super-twisted birefringence effect," in *Proc. Society for Information Display*, 1985, pp. 120–123.
- [87] M. Schadt, R. Buchecker, A. Villiger, F. Leenhouts, and J. Fromm, "The cooperative effects of heterocycles, NCS-polar groups and double bonds on the material properties of nematic liquid crystals," *IEEE Trans. Electron Devices*, vol. ED-33, pp. 1187–1194, Aug. 1986.
- [88] M. Schadt, M. Petrzilka, P. R. Gerber, and Villinger, "Polar alkenyls: Physical properties and correlations with molecular structure of new nematic liquid crystals," *Mol. Cryst. Liq. Cryst.*, vol. 122, pp. 241–260, 1985.
- [89] "New STN wide-angle liquid-crystal display personal word processor Epson Wordbank J," Seiko Epson News Release, Oct. 1986.
- [90] "Introduction of telecomputer *if COM7* in March, 1986," Oki News Release, 1985.
- [91] F. Funada, M. Matsuura, and T. Wada, "Interference color compensation double layered twisted nematic display," Foreign Application Priority Data Dec. 8, 1980 (Japan); U.S. Patent 4 443 065, Apr. 17, 1984.
- [92] H. Wada, S. Wada, C. Iijima, and Publication No. Showa 64-519, "Liquid crystal display device," Priority Data May 19, 1986; Japan Published Unexamined Patent Application Showa 64–519, Jan. 5, 1989.
- [93] "Double super twist nematic ICD—high quality real black-and-white LCD unit—suitable for word processor and PC applications," Sharp Corp. News Release, Sept. 11, 1987.
- [94] O. Okumura, M. Nagata, and H. Wada, "Neutralized STN (NTN)—LCD full color picture image," *Inst. Television Eng.*, vol. 11, no. 27, pp. 79–84, Nov. 1987.
- [95] H. Watanabe, O. Okumura, H. Wada, A. Ito, M. Yazaki, M. Nagata, H. Takeshita, and S. Morozumi, "Full-color LCD with neutralized STN (NSTN)," in *Proc. Society for Information Display*, 1988, pp. 416–419.
- [96] N. Kimura, T. Shinomiya, K. Yamamoto, Y. Ichimura, K. Nakagawa, Y. Ishii, and M. Matsuura, "Multicolor display by double-layered supertwist-nematic LCD," in *Proc. Society for Information Display*, 1988, pp. 49–52.
- [97] H. Koh, K. Sawada, M. Ohgawara, T. Kuwata, H. Tsubota, M. Akatsuka, and K. Matsuhira, "A 960 × 240 pixel multicolor super-twisted-nematic display," in *Proc. Society for Information Display*, 1988, pp. 53–56.
- [98] H. Ohnishi, T. Yoshimizu, S. Wada, H. Kuwagaki, and T. Katsube, "Liquid crystal display device," Priority Data Feb. 6, 1989; Japanese Patent 2 667 716, Oct. 27, 1997.
- [99] B. J. Lechner, F. J. Marlowe, E. O. Nester, and J. Tults, "Liquid crystal matrix displays," *Proc. IEEE*, vol. 59, pp. 1566–1579, Nov. 1971.
- [100] F. Funada, Y. Takafuji, K. Yano, and M. Matsuura, "An amorphous-Si TFT addressed 3.2-in. full-color LCD," in *Proc. Society for Information Display*, San Diego, CA, May 1986, pp. 293–295.
- [101] A. G. Fisher, T. P. Brody, and W. S. Escott, "Design of a liquid crystal color TV panel," presented at the IEEE Conf. Display Devices, Oct. 1972.
- [102] T. P. Brody, J. A. Asars, and G. D. Dixon, "A 6 × 6 in 20 lines-per-inch liquid-crystal display panel," *IEEE Trans. Electron Devices*, vol. ED-20, pp. 995–1001, Nov. 1973.
- [103] F. C. Luo, W. A. Hester, and T. P. Brody, "Alphanumeric and video performance of a 6" × 6" 30 lines/inch TFT-LC display panel," in *Proc. Society for Information Display*, 1978, pp. 94–94.
- [104] M. Matsuura, Y. Takafuji, K. Nonomura, F. Funada, and T. Wada, "A liquid crystal display panel using a Te-TFT array," in *Proc. Society for Information Display*, Philadelphia, PA, May 1983, pp. 148–149.
- [105] T. Yamazaki, Y. Kawahara, S. Motte, H. Kamamori, and J. Nakamura, "A liquid crystal TV display panel with drivers," in *Proc. Society for Information Display*, Philadelphia, PA, 1982, pp. 48–49.
- [106] "Succeeded in the development of a television wrist watch," Seiko Corp. News Release, June 16, 1982.
- [107] S. Morozumi, K. Oguchi, S. Yazawa, T. Kodaira, H. Ohshima, and T. Mano, "B/W and color LC video displays addressed by poly Si TFT's," in *Proc. Society for Information Display*, Philadelphia, PA, May 1983, pp. 156–157.
- [108] P. G. Le Comber, W. E. Spear, and A. Ghaith, "Amorphous-silicon field-effect device and possible application," *Electron. Lett.*, vol. 15, no. 6, pp. 179–181, Mar. 1979.
- [109] A. I. Snell, K. D. Mackenzie, W. E. Spear, P. G. Le Comber, and A. J. Hughes, "Application of amorphous silicon field effect transistors in addressable liquid crystal display panels," *Appl. Phys.*, vol. 24, no. 4, pp. 357–362, Apr. 1981.
- [110] Y. Okubo, T. Nakagiri, Y. Osada, M. Sugata, N. Kitahara, and K. Hatanaka, "Large-scale LCDs addressed by a-Si TFT array," in *Proc. Society for Information Display*, San Diego, CA, 1982, pp. 40–41.
- [111] K. Suzuki, T. Aoki, M. Ikeda, Y. Okada, Y. Zohta, and K. Ide, "High-Resolution transparent type a-Si TFT LCD's," in *Proc. Society for Information Display*, Philadelphia, PA, May 1983.
- [112] S. Hotta, S. Nagata, Y. Miyata, K. Yokoyama, K. Adachi, T. Chikamura, M. Yoshiyama, A. Nishikawa, and K. Kawasaki, "Full-Color multi-gap LC-TV display panel addressed by a-Si TFTs," in *Proc. Society for Information Display*, San Diego, CA, 1986, pp. 296–297.
- [113] "Sharp has developed a 14 TFT color LCD unit," Sharp Corp. News Release, June 24, 1988.
- [114] T. Nagayasu, T. Oketani, T. Hirobe, H. Kato, S. Mizushima, H. Take, K. Yano, M. Hijikigawa, and I. Washizuka, "A 14-in-diagonal full-color a-Si TFT LCD," in *Proc. Int. Display Research Conf.*, San Diego, CA, Oct. 1988, pp. 56–58.
- [115] "Realizing a dream of television hanging on the wall 8.6 inch liquid crystal museum," Sharp Corp. News Release, Apr. 25, 1991.
- [116] G. Weber, U. Finkenzerler, T. Geelhaar, H. J. Plach, B. Rieger, and L. Pohl, "Liquid crystals for active matrix displays," *Liq. Cryst.*, vol. 5, no. 5, pp. 1381–1388, 1989.
- [117] H. J. Plach, G. Weber, and B. Rieger, "Liquid crystal mixtures for active matrix displays using new terminally fluorinated compounds," in *Proc. Society for Information Display*, Las Vegas, NV, May 1990, pp. 91–94.
- [118] "Third quarter 2001 report," Stanford Resources Inc., San Jose, CA, 2001.
- [119] E. H. Howells, Ed., *Technology of Chemical and Materials for Electronics*. Chichester, U.K.: Ellis Horwood, 1984, pt. 1, ch. 3, pp. 43–58.



Hirohisa Kawamoto (Fellow, IEEE) received the B.S. degree in electronics from Kyoto University, Kyoto, Japan, in 1961 and the M.S. and Ph.D. degrees in electrical engineering and computer sciences from the University of California, Berkeley, in 1966 and 1970 respectively.

From 1961 to 1968, he was with the Matsushita Electronic Corporation, Osaka, Japan. In 1970, he was an Acting Assistant Professor with the Department of Electrical Engineering and Computer Sciences at the University of California, Berkeley. From 1970 to 1980, he was with RCA David Sarnoff Research Center, Princeton, NJ. From 1980 to 1985, he was with the Sony Corporation of America, where he was the Founder and General Manager of Sony Consumer Electronics Laboratories, Paramus, NJ. From 1985 to 2001, he was with the Sharp Corporation, Japan, where he participated in the founding of Sharp Laboratories of Europe at Oxford, U.K., and Sharp Laboratories of America at Camus, WA. His last assignment at Sharp was Vice President and Division General Manager of the Technical Information Center. Since July 2001, he has been a Senior Business Advisor with Silicon Image Inc., Sunnyvale, CA, stationed in Nara Gakuen-Mae, Japan. From 1994 to 2000, he was a delegate from Japan to the Committee of Action of International Electro-Technical Commission, Geneva, Switzerland. From 1980 to 1985, he was the Founder and Chairman of the Board of Trustees of the Princeton Community Japanese Language School, Princeton, NJ.

Dr. Kawamoto received the IEEE Centennial Medal and Third Millennium Medal. He was the Chairman of Princeton Section of the IEEE in 1980 and the Conference Chairman of the IEEE International Conference on Consumer Electronics, Chicago, IL, in 1984. He was a Member of the Editorial Board of *Liquid Crystals Today* from 1998 to 1999 and of the PROCEEDINGS OF THE IEEE since 1999.