

# Clothing Repair

Clothing repair and mending can cover a rather wide range of activities varying from those requiring very little skill to those demanding a great deal of sewing skill and expertise. The rewards of mending vary from the self-satisfaction for a job well done to a substantial monetary savings by prolonging the life of a garment.

The need for clothing repair comes from various sources. Poor initial garment workmanship or construction can be a problem with ready-to-wear as well as handmade items.

Everyday wear and tear will also take its toll. Poor garment fit can cause a seam to split or a fastener to break. Still other repairs become part of preventive mending, permitting the garment to be worn longer without the need of major repair or recycling.

Garment repair and mending can require a bit of creativity. Don't be guilty of rushing into a repair job without giving the situation some careful thought and having the necessary tools to see the job through.

## To Mend or Not to Mend

How does one decide? The cost of clothing continues to rise; however, garment cost or replacement is not the only factor to be considered. Answering the following questions should provide some insight.

- How extensive is the repair or damage?
- Do I have the knowledge and skill to repair it, or do I need to take the garment out for repair?

- Is the garment worth repairing? (Consider garment age, current fashion, fit, and its use in the wardrobe. If for a child, will it soon be outgrown or can it be handed down?)
- What is the time element involved in the repair? (Do I have the time to do it? Do I have the time to look for and see to someone else repairing it?)
- Can I afford to replace the garment at this time?
- Will the garment be worn after it is mended?

## Mending Supplies and Tools

Mending supplies and tools can be categorized many ways. However, all items should be kept together in a designated location. Everyone, male and female alike, who is responsible for the care and maintenance of their clothing needs at least a basic mending kit.

### Basic Kit

- Hand needle – package of assorted sizes (3/9)
- Pins – stainless steel pins
- Safety pins
- Scissors
- Liquid fray preventer – found in notion section at fabric store.
- Thread: white, beige, black, brown, or navy to match the basic colors of the wardrobe; medium shade of gray or other color similar to colors in wardrobe.

Other items can be added which are sure to be helpful:

- Assorted snaps, hooks and eyes
- Sewing gauge or small 6-inch ruler

- Seam ripper
- Needle threader
- Fusible bonding web
- Pin cushion
- Iron-on mending tape
- Assorted buttons
- Bodkin

The more advanced or dedicated individual can find and use a wide variety of additional supplies and tools from fusible web to special mending sewing machine attachments.

## Types of Repairs

There are numerous repair or mending methods – some requiring creative talent while others are basic and rather fundamental. Determining which one to use depends on the following factors:

- Location of the damage on the garment
- Type and size of damage
- Shape of the area to be repaired
- Type of fabric – ease of handling
- Type of garment
- The garment's use and place in the wardrobe

## Preventive Mending

Preventive mending includes a variety of things which will keep the garment looking good and delay major repair or mending activities.

**Clipping/Tying Loose Threads** – Newly purchased garments may have loose threads that need to be secured, hidden and/or removed.

**Securing/Reattaching Buttons** – Attach/reattach buttons securely with an adequate thread shank to accommodate the fabric layers and thickness when button is secured in the buttonhole. Buttons on outerwear garments such as raincoats and jackets are less likely to break, disappear or damage the

### Sewing Buttons without Built-on Shank

Use a double strand of either all-purpose, topstitching, or buttonhole thread. Begin on the center line marking.

**Step 1** - Secure beginning thread with a knot or a couple of stitches between the folds of fabric. Hide the knot or clip any loose threads that may show.

**Step 2** - Bring the thread up to the right side of the fabric and through a hole in the button. Thread it back through an adjacent hole.

**Step 3** - Pull the thread, allowing for a sufficient thread shank (use toothpick, shank gauge, pin, or leave space for give) between the button and the fabric.

**Step 4** - Go into the first layer of fabric and the interfacing, picking up several threads of the facing. Slant needle toward the same general location where thread came up through the fabric to the right side. (This will help create a thin rather than thick thread shank.)

**Step 5** - Continue stitching in the same place for approximately four stitches.

**Step 6** - If a toothpick, shank gauge, or pin was used to form the thread shank, remove it and pull the button to the top of the thread. Wind thread around the stitches under the button. Secure thread at the bottom of the thread stem.

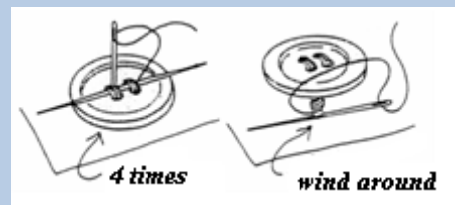

garment if they have a reinforcement button on the underneath side.

**Securing Snaps, Hook & Eyes** – Use needle with double thread. Secure several times in each hole, making stitches neat. Hide and lock stitching on the underneath side.

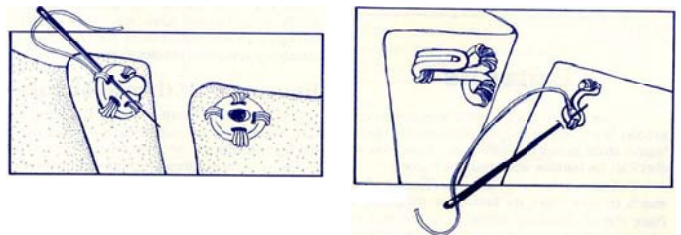

**Split/Ripped Seams** – The easiest method – repair by re-stitching on sewing machine. Seam may be repaired by hand if machine or serger is not available. Determine cause of rip and reinforce or strengthen.

**Reinforce Seam/Area** – Seams/areas under strain or stress need reinforcement to prevent splits. Type of reinforcement will depend on location, fabric, and situation. Types include: double row of machine stitching; using a shorter stitch length; narrowing seam allowance to provide some additional room in garment, and zigzagging edges together; or sewing a small piece of bias tape to the back side, using zigzag or multi-zigzag stitch.

**Raveling Buttonhole** – Repair ravels using liquid fray preventer and/or hand stitching. Check fray preventer (for color change) on an inconspicuous seam before using. The more experienced individual may want to try re-stitching buttonhole on the sewing machine. For hand stitching, the buttonhole stitch is preferred; however, the novice may feel more comfortable using a tight, neat whip stitch. Use double thread.



**Hand worked buttonhole**

**Raveling/Unsecured Hem** – Emergency repairs can be made using double-faced tape or fabric glue, if safe for fabric, or safety pins. Permanently repair by needle and thread, fusible web or sewing machine. Hem stitches should not show on right side of garment; use single thread to secure.

## Darning

Darning is the "reweaving" of fabric in a damaged area, and can be done by hand or sewing machine. Machine darning is faster but more noticeable. Hand darning, which can be invisible to the unknowing eye, is time consuming and requires patience and skill.

## Repairing a Torn Seam

1. Remove stitching from pulled area and 1 inch beyond each end of pulled seam.

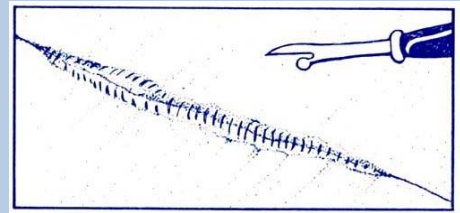

2. Cut two strips of soft, lightweight fusible interfacing, such as fusible knit, as long as the opening and about 1 inch wide. Round off the corners and fuse interfacing to wrong sides of both seam allowances.

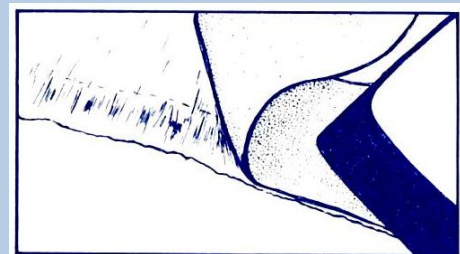

3. Re-stitch seam either by machine or by hand using a backstitch. Reinforce with a second row of stitching if necessary.

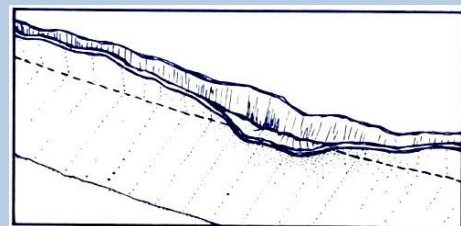

## Hand Darning

Begin by gently trimming away any loose threads or ragged edges. Sewing thread or actual material thread (raveled yarns from the fabric) can be used to repair area. Color and weight should be very close to fabric being darned.

Position the area to be darned over/on a hard surface which duplicates the shape of the garment area, i.e. curved or flat. Using single thread and a very small, fine needle, make a "bridge" of horizontal or vertical threads connecting the edges of the area to be darned.

Using the bridge threads just created, weave additional thread over and under vertically or horizontally, carefully filling in the damaged area.

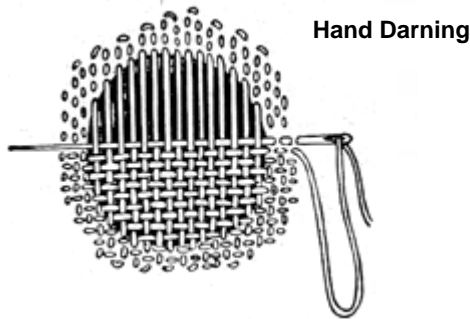

### Machine Darning

Read and follow sewing machine manual recommendation for machine darning.

Gently trim ragged edges and thread along damaged area. In some instances, an underlay of lightweight or matching fabric should be cut and used to strengthen the area and hold the damaged edges in place.

The garment area is easier to handle when placed in sewing machine embroidery or darning hoop accessory. Outline the opening with a straight or zigzag stitch.

The sewing machine feed dog will need to be lowered, since it is not used when darning. Attach the machine's embroider or darning foot.

When stitching, move fabric slowly, stitching lengthwise, then stitch crosswise filling in and strengthening damaged area.

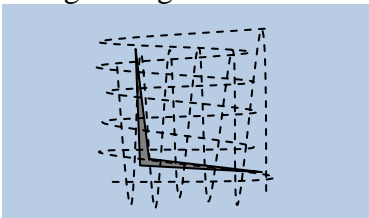

Machine Darning

### Tips and Helpful Suggestions

- Tweeds, plaids, and multi-colored/multi-thread fabrics are easier to repair invisibly than fabrics of solid colors. Textured fabrics blend the darning thread better, with less attention, than smooth fabrics.
- When an exact thread match is not possible, select thread one shade darker. Use extra-fine lightweight thread for light to medium weight fabrics.
- When darning denim jeans, use matching navy or blue thread on top and gray thread in the bobbin. Loosen upper tension, the bobbin thread will pull slightly to the top of the work making mend almost invisible.
- Try using a multi-stitch zigzag stitch or other decorative stitch when area needs to be reinforced as well as repaired.
- Patches and decorative coverings are sometimes a better alternative.

### Patching

Patching is often used when the damaged area is large or is not suited to darning. The repair can be almost invisible, or very decorative in nature. Patching is a sturdy method of garment repair.

Before determining which type of patching method to use, consider carefully the damage location, type of garment, individual who wears the garment, type of fabric and how garment is used. Patching materials can be self-fabric, contrasting fabric, lace, or trim.

The methods of patching include fusing, gluing, hand and machine stitching. It is also possible to use a combination such as fusing and machine stitching as in a decorative appliquéd patch.

## Tips and Helpful Suggestions

- Purchased iron-on patches should be compatible with fiber, color and texture of garment. Wash or dry clean garment before attaching.
- Use fusible web to make iron-on patches from any fabric. Cut fabric and web at least 1 inch larger than area to be patched.
- Surface-applied patches look neater and last longer if edges are hand or machine stitched. Machine stitching can be straight, zigzag or decorative zigzag.
- When applying an invisible-stitched fabric patch, use single thread to attach by hand. If damaged area is trimmed to a square or rectangle shape, applying and stitching the patch is easier.

### Preparation for Patching With a Sewn-on Patch

Cut off the ragged edges of the hole. Cut a piece of sturdy material about 2-inches longer and wider than the hole. If possible, use the same kind of material as the garment.

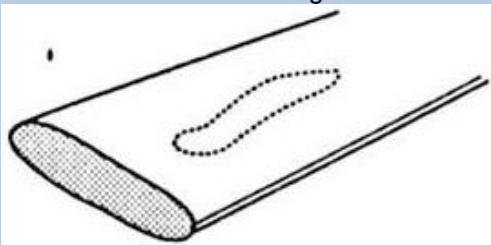

Fold under all the edges of the patch ½-inch. Press the edges to crease them.

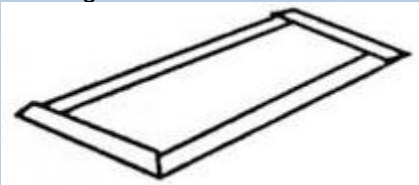

Pin the patch over the hole. Be sure the patch is smooth, flat, and straight on the garment.

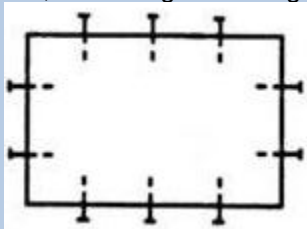

### Sewing on a Knee Patch by Machine

– A machine stitched patch stays on better, but it's hard to do on small pant legs. Be careful when you sew. It's easy to sew the pant leg together by mistake. Start at the bottom of the pant leg and gather it up in your hands to make a nest. The patch will be in the middle of the nest. When you sew, keep pulling the back of the pant leg away from the needle.

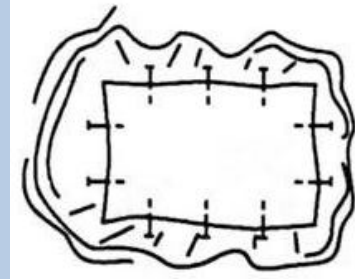

Start sewing at the upper corner of the patch. Use a medium-length stitch. Stitch around the patch close to the edge.

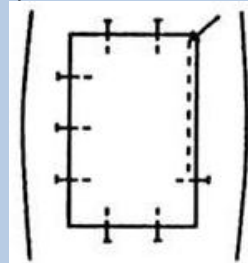

To make a nice corner, stop the machine with the needle down at the corner. Lift the presser foot and turn the pant leg. Lower the presser foot and sew another side. Overlap stitching at the end to keep the stitches from coming out.

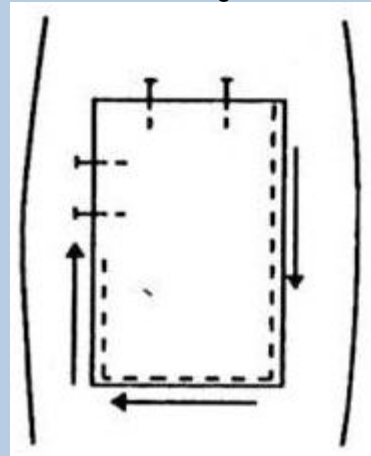

- Fabric patches should be cut on the same grain and design as damaged area to be repaired. Secure with matching thread.
- Decorative patches can actually enhance the appearance of a garment. Add additional decorative patches to balance the garment design, if needed.

Patches can be different shapes. Use pictures in coloring books for patterns.

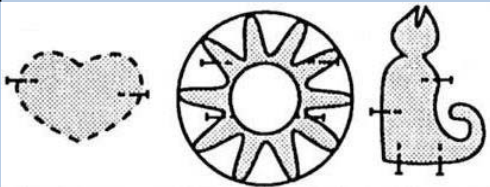

### Sewing on a Knee Patch by Hand –

Use the backstitch for a strong patch. It looks like machine stitches. To backstitch, push the needle from inside the pants through the pant leg and patch. Push the needle down through the material about 1/8 inch back from where you started. Bring the needle out one stitch in front of that stitch. Keep backstitching around the patch.

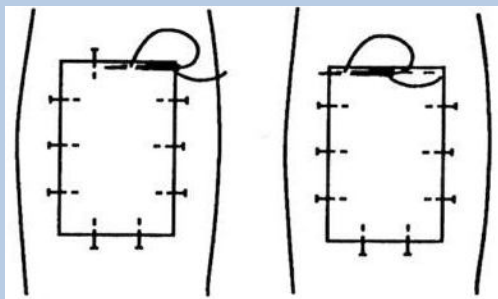

## Replacement

Replacement generally requires the removal of a section or part of the garment so that a new portion or part can be installed. Replacement can require a great deal of skill, or just a little time and creative thought.

## Repairing a Tear, Cut, or Small Hole Without Sewing

Press the torn area to even up threads which may have been pulled off grain. Trim loose threads from edges of the tear.

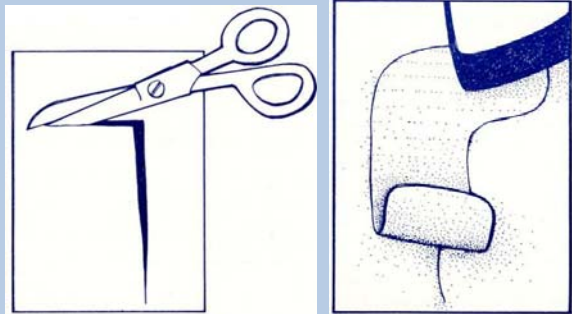

Place tear, face down, on pressing surface, gently bringing edges together. If there is a hole, cut a small patch of matching fabric from the hem or other concealed area of the garment. Place fabric over hole before fusing. Cut patch from fusible interfacing or mending fabric 1 inch larger than tear or hole. Round the corners. Place patch, fusible side down, over tear or hole. Touch tip of hot iron to patch to tack in place.

Turn garment right side up to check placement of patch. Make sure cut edges meet, covering patch. Press to fuse following directions on package. Let cool before handling.

**Garment section** – Almost any section of a garment can be replaced depending on the skill of the individual doing the repair and the necessary fabric (matching, coordinating) to complete the task. Frequent replacements include pockets, knit sleeve cuffs, and linings. Creative and decorative replacement could include such things as collar and sleeves. The belt of a garment may need to be replaced, or a belt may be added to a garment. Belts can be made or purchased. Scarves can also serve as belts.

**Zipper** – Select a replacement zipper similar to the one removed, or the most suitable zipper available. Carefully remove old zipper from garment, taking note as to how it was sewn. Zipper replacement on ready to wear garments differs slightly from directions that may come with the replacement zipper.

**Elastic** - Remove the old elastic carefully from casing or garment area. Purchase or replace casing types with elastic similar to that which was removed. To determine the amount (length) needed, measure comfortably around body part. Allow 1 inch for securing elastic ends. When elastic is to be stitched to garment instead of threaded through casing, fit elastic more snugly by reducing the length by 2-3 inches.

**Belt Carriers** – Remove old thread or fabric carrier. Replace with thread carrier. To make a thread carrier, thread a needle with matching or coordinating thread. Using double thread, secure on back side of garment; bring thread through to right side. Take a tiny stitch in the same location where thread was brought through, leaving a loop in thread. Drop needle and begin finger-crocheting a chain or looping the thread close to the fabric. Continue chaining until carrier is the desired length for belt to pass through comfortably. Pull needle through the loop securing thread and loops. Secure carrier to garment with 2-3 small stitches.

## Other Repairs and General Maintenance

There are other repairs and maintenance activities performed which will prolong garment wear-life and/or improve appearance. Several of these follow on the next page.

**Hems** – Whether a hem has come loose or the hemline length has changed, repairing a hem is one of the most frequently made repairs. Choose a thread color that closely matches the garment fabric and use a small needle with a single thread. Thread from the original hem may be salvaged, especially if the garment is factory made. Hemming machines used for ready-to-wear garments typically use three times the length of thread required for a hand stitched hem. See diagram for removing a chain stitched hem.

### Making a Thread Chain

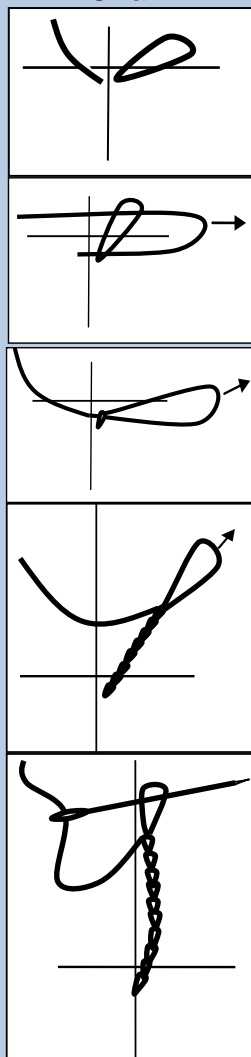

Using matching double thread firmly secure thread. Take a very small stitch, leaving a loop in the thread. Release the needle.

Using your fingers, pull a new loop of thread through first loop.

Pull loop very snug tightening first loop next to the fabric.

Continue the looping process to create the desired length. Make sure loops are very secure and snugly positioned against the previous loops.

Insert the needle through the last loop to lock. Secure to the adjacent fabric segment and hide thread ends.

Machine stitching with a double needle is a good alternative to repairing a factory cover-stitched hem. These hems are common on knit garments and frequently come undone.

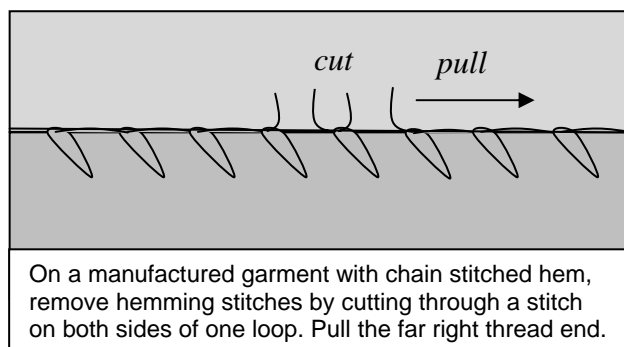

## Making a New Hem

**Take out the hem** – Pull out the old hem stitches. Press out the crease from the old hem. Use a steam iron or a damp clean cloth or paper towel between the hem and the iron.



**Mark the new hem** – Temporarily pin up the hem to see where it looks best. Mark a yardstick or broom handle with the measurement from the floor to desired hemline. Take out the pins.

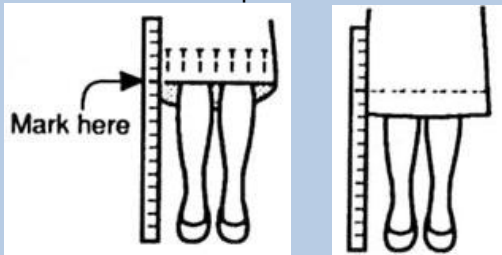

Have someone mark the hem evenly all the way around with pins using the guide on the yardstick.

**Turn up the hem** – Fold up the hem so the marking pins are on the fold, and pin. Try on the garment to see if the hem is even. Press the hem fold. Do not press over the marking pins; remove them as you press.

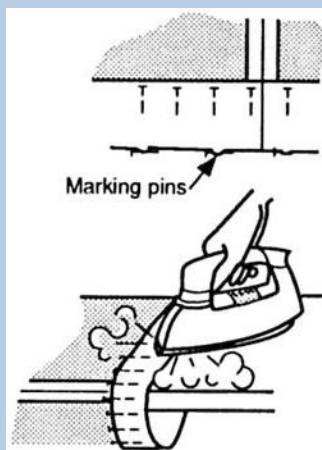

**Trim the hem to an even width** – Decide how wide to make the hem.

- 2 inches for most cloths
- 1 to 1½ inches for pants and flared skirts

Make a marker the size you want your hem. Use a ruler or a piece of light weight cardboard with a notch in the side. Place one end of the marker on the fold of the hem. Trim the hem by cutting to the notch. Continue moving the marker and cutting all the way around the hem. Be careful to cut through only along the hem allowance.

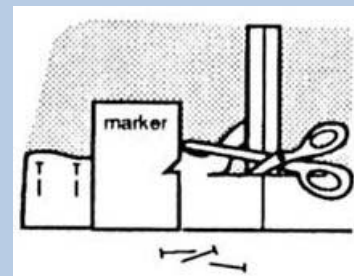

**Finish the edge** – If the fabric ravels, finish the edge.

By machine – Stitch near the edge. A zigzag stitch works better than a straight stitch.

By hand – Turn under the edge ¼-inch and press it flat.

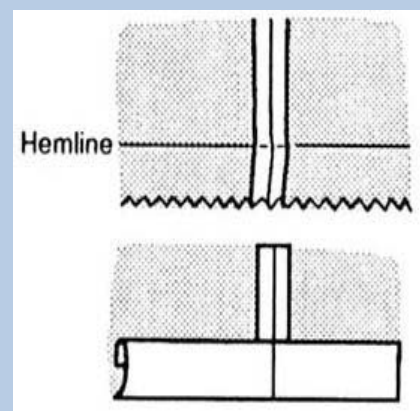



**Make the new hem** – Try one of these ways:  
**Hand Hem** – You can use this for most clothes. Turn it inside out. Fold the hem back so only ¼ inch of the hem shows past this fold.

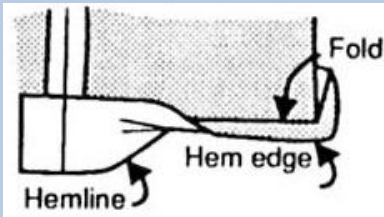

Take a small stitch in the hem about ¼ inch from the edge. If you turned under the hem edge, make this stitch through both layers of fabric.

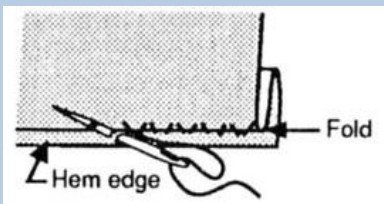

Then ½ inch away, pick up 1 or 2 threads from the fold. Don't pull the thread too tight—the hem will show less if the stitches are loose.

**Fusible Web** – Try this for pants and skirts that are quite straight. You can use fusible web instead of stitching to hold the hem in place. You can buy fusible web in strips or in large pieces.

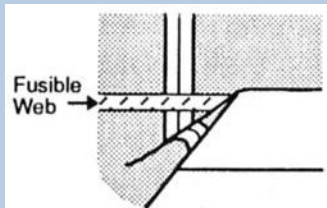

Use a piece of web. Test to see if it holds and looks right on your fabric. Cut the fusible web into strips ¼ inch to ½ inch wide. Put the web inside the hem, just below the top to keep the web from sticking to the iron.

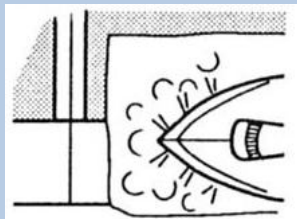

Follow the instructions that come with the fusible web to press it in place.

**Repairs to vinyl or windbreaker-type nylon**– For a washable garment, cut a patch and glue in place using a vinyl adhesive.

**Repairing pulled threads in woven fabric** – Gently work with fabric to ease thread tension and re-position thread. Unless thread is broken, pull thread to wrong side of garment using a needle threader. If thread is broken, thread into a needle and pull through. In some instances, the thread may be close enough to a seam line or other line of stitching that it can be worked into that area.

**Repairing pulled threads in knits** – Repair must be done by hand. Unless the thread is broken, use a needle threader or a knit repair tool to pull the thread to the wrong side of the garment. Gently stretch the knit and attempt to reposition the pulled yarn. If yarn/thread is broken, attempt to thread through a needle and push to wrong side. Thread needle with matching thread and whip the yarns together; secure thread well. Use a liquid seam/fray preventer if appropriate.

**Removing pills** – The most effective means of removing pill balls is by carefully cutting them off. The small battery-operated pill removing devices on the market are generally very effective and safe for clothing when used properly. Look for other products, including sweater brushes, to assist with the removal of pills. Always read and follow product recommendations.

## Buy Carefully, Mend Less

One way to help keep repair of clothing at a minimum is to check garments carefully before you buy them. When you shop, follow these suggestions:

- Pick types of garments best suited to your family's needs and to the kind of care these clothes will get.

- Check sizes and fit. Getting the right fit avoids strains that cause damaging rips and tears later.
- Study style features and trimmings to see if they will hold up in use. Some, although satisfactory in dress clothes, are not practical in garments for work or play.
- Look for flaws. Examine the workmanship of a garment, outside and inside; to make sure it is appropriate and serviceable for the material, style, and cut of the garment, as well as for the use and care it will get.
- Take time to pick the best garment, whether clothes are piled in a stack or hanging from a rack. All clothes of a kind, or even a size, are not equally good quality. While one choice seems as good as another, clothes are made by individuals, some of whom are more skilled and exacting than others.

For more information on hand stitches and hems, see *Hand Stitches (CT-MMB.002)* and *Hems (FCS2-320)*.

## References:

- Heaton, L.M. (1996). *Clothing Repair (CT-LMH.147)*. Unpublished manuscript, University of Kentucky.
- Dedic, B.J. (1987). *Quick Clothing Repair (H.E. 2-305)*. Unpublished manuscript, University of Kentucky.
- Southern Region Agricultural Research Service (1976). *Clothing Repairs*. Home and Garden Bulletin no.107, U.S. Department of Agriculture.

Sections adapted for use in Kentucky from *How to Make a New Hem* and *How to Patch Knees in Pants*, 1978, North Central Region Project by Textiles and Clothing Extension Specialists.

Marjorie M. Baker, M.S.  
Extension Associate for Clothing and Textiles

October 2007

Copyright © 2007 for materials developed by University of Kentucky Cooperative Extension. This publication may be reproduced in portions or its entirety for educational or nonprofit purposes only. Permitted users shall give credit to the author(s) and include this copyright notice.

Educational programs of Kentucky Cooperative Extension serve all people regardless of race, color, age, sex, religion, disability, or national origin.