



VERMONT

DEPARTMENT OF ENVIRONMENTAL CONSERVATION

2023 VERMONT WASTE COMPOSITION STUDY

Final Report

May 23, 2024

Submitted by



DSM ENVIRONMENTAL SERVICES, INC.

This report has been prepared in collaboration with the following team members:



Although the information in this document has been funded wholly or in part by the United States Environmental Protection Agency under assistance agreement 00A01258 to the Vermont DEC, it has not been subjected to the Agency's publications review process and therefore, may not reflect the views of the Agency and no official endorsement should be inferred.

 This report was printed using recycled-content/FSC-certified paper. Please recycle when no longer needed.

TABLE OF CONTENTS

Acknowledgements

E. EXECUTIVE SUMMARY & KEY FINDINGS	E-1
E.1 Vermont Municipal Solid Waste Composition.....	E-1
E.2 Key Findings.....	E-2
1. INTRODUCTION.....	1-1
1.1 Introduction.....	1-1
1.2 Research Overview & Report Organization	1-1
1.3 Waste Generation.....	1-3
1.3.1 Reported Disposal.....	1-3
1.3.2 Gate Survey of MSW Loads	1-3
1.4 Waste Composition Methodology Summary	1-6
2. MUNICIPAL SOLID WASTE COMPOSITION	2-1
2.1 Aggregate MSW Composition	2-1
2.2 Residential Composition	2-9
2.3 ICI Composition	2-13
2.4 Comparisons of Residential & ICI Waste Disposal.....	2-17
3. CONSTRUCTION & DEMOLITION WASTE COMPOSITION	3-1
3.1 C&D/Bulky Waste Composition	3-1
3.2 Comparisons with 2018 Study.....	3-6
4. ANALYSIS OF VERMONT WASTE COMPOSITION	4-1
4.1 Vermont Aggregate Waste Composition.....	4-1
4.2 Recovery Rates	4-5
4.2.1 Recycling Recovery Rate	4-5
4.2.2 Food Scrap Recovery Rate.....	4-6
5. MRF RESIDUE COMPOSITION.....	5-1
5.1 Residue Streams.....	5-1
5.2 Comparison of Residue Composition.....	5-6
5.3 Tubs & Lids Composition	5-10
5.4 Supplemental Observations.....	5-11
6. RESIDENTIAL FOOD SCRAP MANAGEMENT RESEARCH	6-1
6.1 Overview	6-1
6.2 Estimated Diversion of Residential Food Waste from Disposal in Vermont	6-1
6.3 Comparison of 2017 & 2023	6-4

TABLE OF CONTENTS

6.4	Impact of Vermont’s Landfill Ban on Food Waste Disposal.....	6-5
6.5	Limitations	6-5
7.	ORGANICS MANAGEMENT TRANSPORTATION RESEARCH	7-1
7.1	Introduction & Summary.....	7-1
7.2	Methodology.....	7-1
7.3	Response Rates.....	7-2
	7.3.1 Food Scrap Generators	7-2
	7.3.2 Food Scrap Transporters	7-3
7.4	Research Results.....	7-3
	7.4.1 Direct Disposition & Backhaul of Food Scraps by Generators	7-3
	7.4.2 Food Scrap Transporters	7-5
7.5	Limitations	7-7
8.	DIRECT-TO-BROKER RECYCLING RESEARCH.....	8-1
8.1	Introduction.....	8-1
8.2	Methodology.....	8-1
8.3	Response Rates.....	8-2
8.4	Questionnaire Results.....	8-3
8.5	Limitations	8-6

LIST OF APPENDICES

Appendix A – Study Design

Appendix B – Questionnaire Forms

Appendix C – UNH Survey Center – Residential Food Scrap Questionnaire Report

List of Figures

Figure E-1 2023 Aggregate (Res. & ICI) MSW Composition with Expanded Organics & Special/Other Groups E-1

Figure E-2 Comparison of Selected Constituents in Aggregate MSW, 2023 vs. 2018..... E-2

Figure 1-1 Comparison of MSW and C&D Disposal, 2018 vs. 2023..... 1-6

Figure 1-2 Map of Disposal and Recycling Facilities Targeted for Study 1-7

Figure 1-3 MRF Residue Hand Sort 1-14

Figure 1-4 MSW Hand Sort 1-14

Figure 1-5 C&D/Bulky Visual Survey..... 1-14

Figure 2-1 2023 Aggregate MSW Composition by Material Group 2-1

Figure 2-2 2023 Aggregate MSW Composition with Expanded Organics and Special/Other Groups 2-2

Figure 2-3 Comparison of MSW Composition, 2023 vs. 2018..... 2-3

Figure 2-4 Comparison of Selected Constituents in MSW, 2023 vs. 2018 2-4

Figure 2-5 Top 10 Constituents in Aggregate MSW 2-4

Figure 2-6 Divertibility of MSW in 2023..... 2-5

Figure 2-7 Comparison of MSW Divertibility, 2023 vs. 2018..... 2-6

Figure 2-8 Bottle and Can Composition in Aggregate MSW 2-9

Figure 2-9 Comparison of Residential MSW Composition by Material Group, 2023 vs. 2018..... 2-10

Figure 2-10 Comparison of Residential MSW Divertibility, 2023 vs. 2018 2-10

Figure 2-11 Bottle and Can Composition in Residential MSW 2-13

Figure 2-12 ICI Composition by Material Group, 2023 vs. 2018 2-13

Figure 2-13 ICI Composition by Divertibility, 2023 vs. 2018..... 2-14

Figure 2-14 Bottle and Can Composition in ICI MSW 2-17

Figure 2-15 Residential vs. Commercial MSW Composition..... 2-18

Figure 2-16 Residential vs. Commercial Top 10 Constituents..... 2-18

Figure 2-17 Residential vs. Commercial Top 10 Recyclable Constituents 2-19

Figure 3-1 Weight-Based Composition of C&D Waste Based on MSW Material Groups 3-1

Figure 3-2 Weight-Based Composition of C&D Waste Based on C&D Material Groups 3-2

Figure 3-3 Recoverability of C&D Wastes..... 3-3

Figure 3-4 Comparison of Visually Surveyed C&D Composition, 2023 vs. 2018..... 3-6

Figure 3-5 Comparison of C&D Waste Recoverability, 2023 vs. 2018 3-6

Figure 3-6 Top 10 Most Prevalent C&D Wastes, 2023 vs. 2018..... 3-7

Figure 4-1 Vermont Statewide Disposed Waste (MSW + C&D) Composition by Material Group 4-1

Figure 4-2 Vermont Disposed Waste Composition by Divertibility 4-2

Figure 5-1 Generic Weighting of MRF Residue Streams 5-2

Figure 5-2 Estimated Composition of MRF Residue by Material Group..... 5-3

Figure 5-3 Estimated Composition of MRF Residue by Divertibility Class..... 5-4

Figure 5-4 Comparison of MRF Residue Composition by Source 5-6

Figure 5-5 Comparison of MRF Residue Divertibility by Source 5-7

Figure 5-6 Top Ten Most Prevalent Materials 5-7

TABLE OF CONTENTS

Figure 5-7 Plastic Materials Observed in Residue.....	5-8
Figure 5-8 Paper Materials Observed in Residue.....	5-8
Figure 5-9 Metal Materials Observed in Residue.....	5-9
Figure 5-10 Other Materials Observed in Residue.....	5-9
Figure 6-1 Reported Disposition of Residential Food Waste.....	6-2
Figure 7-1 Direct Food Scrap Diversion Pathways Reported by Vermont Generators.....	7-5
Figure 7-2 Food Scrap Disposition Reported by Responsive, Permitted Transporters (2022).....	7-7
Figure 8-1 Direct-to-Broker Material Quantities, 2023 and 2018 Reports.....	8-6

List of Tables

Table 1-1 2022 Reported Vermont Waste Generation.....	1-3
Table 1-2 Summary of Gate Surveys.....	1-4
Table 1-3 MSW Gate Survey Results.....	1-5
Table 1-4 2023 Adjusted Vermont Waste Generation (Tons).....	1-5
Table 1-5 Field Data Collection Schedule (CY23).....	1-8
Table 1-6 Sample Summary for Hand Sorts of MSW.....	1-8
Table 1-7 Sample Summary for Visual Surveys of C&D Loads.....	1-9
Table 1-8 Sample Summary for Hand Sorts of MRF Residue.....	1-9
Table 1-9 Material Categories & Divertibility Classes – MSW Hand Sorts.....	1-11
Table 1-10 Material Categories & Divertibility Classes – MRF Residue Hand Sorts.....	1-12
Table 1-11 Material Categories & Divertibility Classes – C&D/Bulk Visual Survey.....	1-13
Table 2-1 Detailed Composition of Aggregate MSW.....	2-7
Table 2-2 Breakdown of Bottles and Cans in Aggregate Disposed MSW.....	2-8
Table 2-3 Detailed Composition of Residential MSW.....	2-11
Table 2-4 Breakdown of Bottles and Cans in Residential MSW.....	2-12
Table 2-5 Detailed Composition of ICI MSW.....	2-15
Table 2-6 Breakdown of Bottles and Cans in ICI MSW.....	2-16
Table 3-1 C&D Visuals Detailed Composition.....	3-4
Table 3-2 C&D Visuals Detailed Composition (Based on C&D Material Groups).....	3-5
Table 3-3 Containers Found In C&D Samples.....	3-5
Table 4-1 Vermont Statewide Aggregate Waste Composition (MSW & C&D).....	4-4
Table 4-2 Vermont Statewide Recycling Recovery Rate.....	4-6
Table 4-3 Basis for Vermont Statewide Food Scrap Recovery Rate Estimates.....	4-7
Table 4-4 Vermont Statewide Food Scrap Recovery Rate Estimates.....	4-8
Table 5-1 Sample Acquisition from Discrete Residue Sources at Host MRFs.....	5-1
Table 5-2 Recycling & Residue Tons at Host MRFs (2023).....	5-2
Table 5-3 Estimated Composition of MRF Residue in the Aggregate.....	5-5
Table 5-4 Components of MRF Residue.....	5-6
Table 5-5 Residue Composition by Ejection Point.....	5-10
Table 5-6 Detailed Composition of Plastic Tubs and Lids.....	5-11

TABLE OF CONTENTS

Table 6-1	Estimated 2023 Diversion of Residential Food Waste	6-3
Table 6-2	Estimated Residential Food Waste Diversion and Disposal (2023).....	6-4
Table 6-3	Comparison of Per Capita Residential Food Waste Disposal.....	6-5
Table 7-1	Food Scrap Landfill Ban Timeline	7-1
Table 7-2	Food Scrap Generator Questionnaire Response Summary.....	7-3
Table 7-3	Food Scrap Transporter Questionnaire Response Summary.....	7-3
Table 7-4	Direct Food Scrap Diversion Reported by Vermont Generators (2022 Tons).....	7-4
Table 7-5	Estimated Food Scrap Transportation by Food Type and Pathway.....	7-6
Table 7-6	Tons Not Otherwise Reported to the State.....	7-6
Table 8-1	Materials Identified in the Direct-to-Broker Questionnaire.....	8-2
Table 8-2	Direct-to-Broker Questionnaire Summary.....	8-3
Table 8-3	Percentage of Respondents Using Recycling Haulers	8-3
Table 8-4	Verified 2023 Direct-to-Broker Tonnage.....	8-3
Table 8-5	Reported 2018 Direct-to-Broker Tonnage Now Collected by Third-party Haulers	8-4
Table 8-6	2018 Direct to Broker Tonnage from Unresponsive Businesses in 2023	8-5
Table 8-7	Adjusted Direct to Broker Tonnage from Unresponsive Businesses in 2023.....	8-5

TABLE OF CONTENTS

This page is intentionally left blank.

ACKNOWLEDGEMENTS

The MSW Consultants-DSM Team would like to thank the following parties for their assistance during various stages of this project.

- All Cycle Transfer Station, Williston
- Brattleboro Transfer Station, Brattleboro
- Casella NEWSVT Landfill, Coventry
- Central VT Transfer Station, Montpelier
- Chittenden County Solid Waste District MRF, Williston
- Gleason Road Transfer Station, Rutland
- Myers C&D Recycling Facility, Colchester
- Rutland County Solid Waste District MRF, Rutland

This study would not have been successful without the ongoing cooperation of the facility hosts, and the guidance and data provided by the Department of Environmental Conservation staff.

ACKNOWLEDGEMENTS

This page is intentionally left blank.

E. EXECUTIVE SUMMARY & KEY FINDINGS

E.1 VERMONT MUNICIPAL SOLID WASTE COMPOSITION

It has been five years since Vermont performed a statewide waste composition study¹ (2018 Study). This 2023 study update found that current waste stream composition is very similar to the 2018 results, for both municipal solid waste (MSW) – generally considered household and business trash – and construction and demolition (C&D) wastes. Proportions of the waste stream that are residential versus “ICI” (industrial, commercial, and institutional) are also similar: in 2018, the split was 44 percent Residential, 38 percent ICI, and 16 percent C&D vs. 2023 findings of 43.6 percent Residential, 37.7 percent ICI, and 18.7 percent C&D. Figure E-1 shows the breakdown of Vermont MSW by material group. This estimate is based on hand sorting of trash samples (i.e., MSW) at four trash disposal facilities around Vermont.

Figure E-1 2023 Aggregate (Res. & ICI) MSW Composition with Expanded Organics & Special/Other Groups

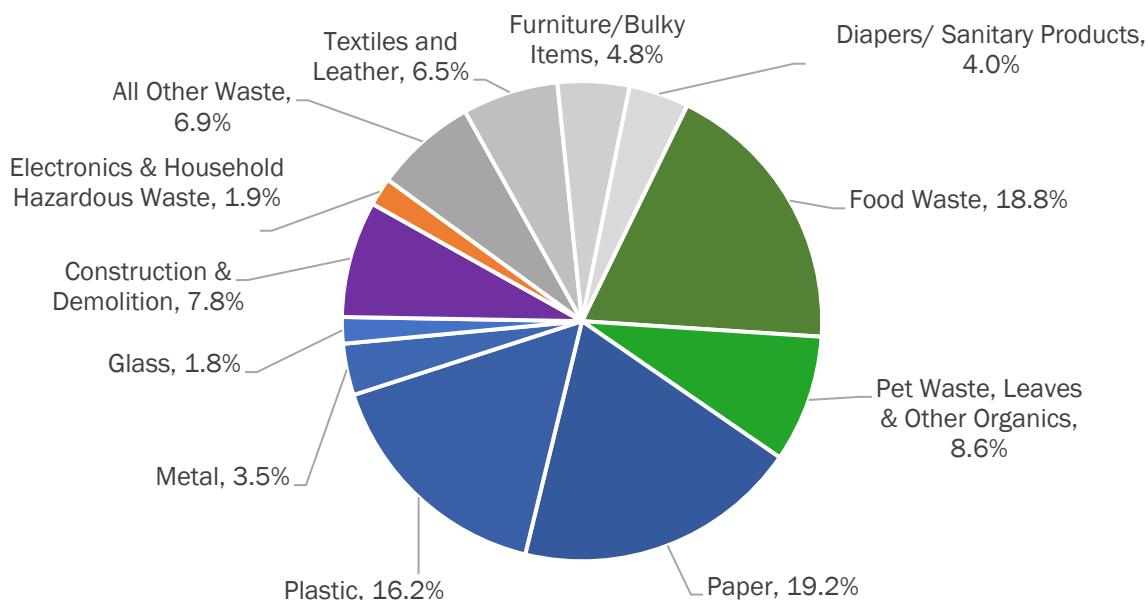

Consistent with the 2018 Study, paper, and plastic (blue pie slices), organics (green pie slices), and special/other wastes (gray pie slices, which includes diapers/sanitary products, furniture/bulky items, textiles and leather, and other wastes) were the most prevalent MSW materials disposed in landfills or incinerators in 2023. DEC and the Project Team estimate that over 43 percent of the MSW waste stream is not currently divertible from the trash in Vermont, while 24 percent is potentially divertible outside of traditional mixed recycling programs. Potentially divertible items include materials like compostable paper, textiles, books, small appliances and electronics, some rigid plastics and clean plastic films, and scrap metal. These materials could potentially be recycled when they are collected separately, like electronics at Special Recycling drop-offs, transfer stations, or scrap metal recyclers (certified salvage yards).

¹ 2018 *Vermont Waste Characterization Final Report*, prepared for Vermont Department of Environmental Conservation, Solid Waste Program, December 14, 2018.

E. EXECUTIVE SUMMARY & KEY FINDINGS

Figure E-2 compares the disposal of selected material categories between the 2023 and 2018 studies. As shown, film plastic, other rigid plastic, pet waste, and textiles and leather have seen the largest increases, while food waste, other organics, and furniture/bulky items experienced the largest decreases measured in percentage terms.

Figure E-2 Comparison of Selected Constituents in Aggregate MSW, 2023 vs. 2018

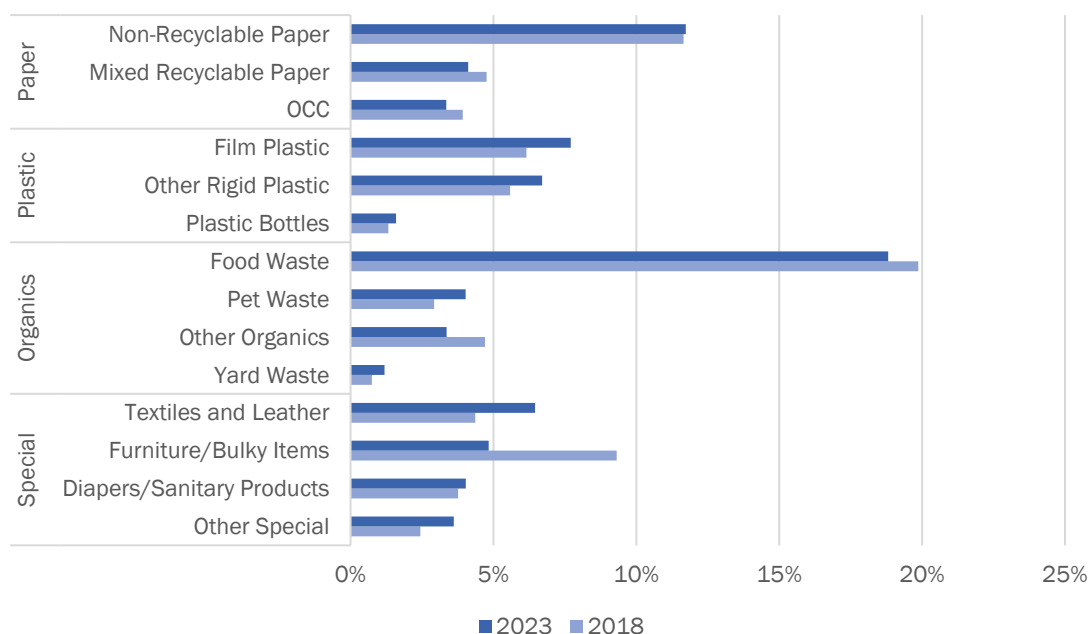

E.2 KEY FINDINGS

1. **Evolving Waste Composition:** Statewide MSW disposal decreased between the two studies (2018 to 2023) by roughly five percent even though the population grew by roughly 3.5 percent. The composition of disposed MSW continues to evolve with macroeconomic changes, including consumer behavior, changes to packaging, and regulatory changes. Several factors likely contribute to the decline in disposal, such as the lightening of materials (using thinner plastic bottles and more bags or film plastic) and the State’s disposal bans on materials like mandated recyclables and food scraps.
2. **Lower Disposal of Food Scraps:** Although the **percentage** of food scraps disposed in MSW waste decreased very little (18.8 percent in 2023 vs. 19.4 percent in 2018), the underlying **tonnage** has decreased by 13 percent. This supports the effectiveness of the mandated food waste disposal ban.
3. **Food Waste Recovery Rate:** The 2023 Waste Composition Study made a first estimate of Vermont’s Food Waste Recovery Rate of 50.7 to 56.8 percent. The Project Team is not aware of other states that have attempted to estimate their food waste recovery rate. While little data is available, the Project Team believes this estimate may be at the high end of food waste recovery rates in the United States.
4. **Mandated Recyclables:** While the percentage of mandated recyclables in MSW decreased only slightly from 12.2% in 2018 to 11.3% in 2023, the state continues to maintain an effective recovery rate for mandated recyclables of approximately 72.1%. This is comparable to the 72% recyclables recovery rate reported in 2018. In the opinion of the Project Team, these rates are well above average for municipal recycling programs.
5. **Reported MRF Residue Rates:** Vermont’s two Material Recycling Facilities (MRFs) reported an average nine percent contamination or “residue” rate in 2023. This is impressive as some U.S. MRF residue rates are as high as 25%. Vermonters generally keep recycling contamination to a minimum.

E. EXECUTIVE SUMMARY & KEY FINDINGS

6. **MRF Residue Composition:** For the first time, this study included hand sorting of MRF residue samples and found that 75 percent of the residue was non-divertible, 17 percent was potentially divertible, and 7 percent was mandated recyclables. However, it is possible that many of the mandated recyclable items were too contaminated to be recycled. Also, the 17 percent of potentially divertible items includes materials that are only divertible if collected separately, not in the mixed recycling the MRF manages. These separate collections are not all available statewide. Of the mandated recyclables in the residue, about 3.5 percent was paper (cardboard, boxboard, office paper, mail, etc.) and 3.5 percent was plastic, metal, and glass containers (bottles, cans, jars, jugs, packaging). “Not recyclable in a MRF” plastic was a large 28.3 percent of residue, mostly film plastic (14.5 percent) and bulky composite items that were predominantly plastic (4.6 percent). This highlights the problems with plastic waste.
7. **Beverage Containers:** Beverage containers (plastic, aluminum, and glass bottles and cans) were observed to be approximately 3.0 percent of the total MSW waste stream as follows: 0.8 percent Bottle Bill (BB), 1.2 percent Expanded Bottle Bill (EBB), and 1.0 percent Non-Bottle Bill (NBB). This suggests that bottle bill containers are being effectively recovered through the Bottle Bill redemption system or the regular “blue bin” mixed recycling system. Expansion of the bottle bill system (EBB)² might increase recycling of additional PET bottles and additional glass bottles, with smaller gains in HDPE bottles. Expansion would produce limited gains with aluminum cans and #3-#7 plastic bottles. Since only about 1.2 percent of the overall MSW was containers that would be part of an Expanded Bottle Bill (EBB), such expansion would have a relatively small impact on Vermont’s total diversion of materials, as measured by weight.³ This conclusion assumes that, after expansion, EBB containers would still be recycled through either the Bottle Bill redemption system or the regular “blue bin” recycling system.
8. **Plastics:** Plastics, including films and rigids, have grown from 12.7 percent in 2018 to 16.2 percent in 2023 of Vermont’s aggregated MSW. This increase would seem even larger if this comparison was made by volume. As noted above in the MRF Residue Composition bullet, plastics also make up 28.3 percent of MRF residue and only a small portion of these (less than five percent) are rigid and recyclable at MRFs.
9. **Textiles:** Textiles also grew as a portion of Vermont’s aggregated MSW, from 4.2 percent in 2018 to 6.5 percent in 2023. At 24,413 tons, there were more textiles in the MSW waste stream than electronics and furniture/bulky items combined. With a high potential for reuse and recycling, existing systems for textiles could be improved or expanded.
10. **Construction and Demolition (C&D) Waste:** Vermont’s C&D waste is measured separately from MSW and is also found in MSW. When this is all added together, C&D waste makes up 23.7% of Vermont’s total waste. C&D waste is challenging to separate, reuse, or recycle. Asphalt shingles in C&D waste grew from 18 percent in 2018 to 25 percent in 2023. Shingles have been found to contain PFAS chemicals, which makes them difficult to recycle. Alternatives like metal roofing can increase the longevity of roofs and are recyclable at end-of-life. Additionally, bulky materials in C&D waste, like mattresses, boxsprings, and soft furniture, have remained a sizable portion of Vermont’s C&D waste at 6.5 percent in 2018 and 6.6 percent in 2023. Reuse opportunities could potentially be improved for bulky goods like mattresses and couches. Diversion could also be expanded, like mattress recycling, which has begun in Chittenden County.

² Expanded Bottle Bill would include non-carbonated water, wine, alcoholic hard cider, and juice bottles as well as non-carbonated energy drinks. Excludes rice milk, soy milk, milk, and dairy.

³ While volume of lightweight but high-volume containers and material type are important considerations, it was beyond the scope of this project to measure and analyze by volume.

E. EXECUTIVE SUMMARY & KEY FINDINGS

This page is intentionally left blank.

1. INTRODUCTION

1.1 INTRODUCTION

10 V.S.A. § 6604(a)(2)(A)¹ calls for an “analysis of the volume and nature of wastes disposed of in Vermont” every five years. This analysis is used to assess progress toward the many goals incorporated into the Vermont Materials Management Plan, which was last updated in 2019.² Gaining a better understanding of the solid waste generated and currently disposed in Vermont will provide information that can be used to improve material-specific waste diversion programs and to assess the efficacy of current laws, actions, and programs.

It has been five years since Vermont last performed a statewide waste composition study³ (2018 Study). Since then, Vermont’s Universal Recycling law fully banned food scraps from disposal in the trash and the Single-Use Products law banned the use and sale of expanded polystyrene food and beverage containers and regulated the use of plastic carry-out bags, straws, and stirrers. The Universal Recycling law also previously banned disposal of mandated recyclables which defined in statute “...means the following source separated materials: aluminum and steel cans; aluminum foil and aluminum pie plates; glass bottles and jars from foods and beverages; polyethylene terephthalate (PET) plastic bottles or jugs; high density polyethylene (HDPE) plastic bottles and jugs; corrugated cardboard; white and colored paper; newspaper; magazines; catalogues; paper mail and envelopes; boxboard; and paper bags.” Additionally, since the last study, the State and local governments have increased outreach and education efforts and several product stewardship initiatives have matured. These efforts are shifting the landscape of materials management in Vermont. New data are required to assess the size and extent of these changes and the continued evolution of the waste stream.

The Vermont Department of Environmental Conservation (DEC) therefore commissioned an update to its statewide waste characterization study. The 2023 Waste Characterization Study incorporates extensive field data collection with results applied to 2022 statewide tonnage data. The primary objective of this update, as well as prior studies, is to use statistically reliable methods at the 90 percent confidence level to characterize the composition (types and amount) of materials that are generated by Vermonters and destined for disposal in landfills or waste to energy facilities, and to generate estimates of hard-to-track diversion of recycling and food scraps from the waste stream. The 2023 Study is intended to be comparable to the 2018 Study to maintain comparability in the State’s waste composition time series and integrates several new research objectives.

1.2 RESEARCH OVERVIEW & REPORT ORGANIZATION

The Project Team of MSW Consultants and DSM Environmental Services was hired to perform the 2023 Study. The 2023 Study incorporated six major research tasks, four of which were reperformed from the 2018 Study plus two new tasks. The remainder of this report is organized into sections corresponding to these primary research tasks and offers conclusions that can be inferred from the project. Specific report sections include:

¹ “(A) An analysis of the volume and nature of wastes generated in the State, the source of the waste, and the current fate or disposition of the waste. Such an analysis shall include a waste composition study conducted in accordance with generally accepted practices for such a study.”

² 2019 *Vermont Materials Management Plan: Reducing Solid Waste & Increasing Recycling and Composting*, November 19, 2019.

³ 2018 *Vermont Waste Characterization Final Report*, prepared for Vermont Department of Environmental Conservation, Solid Waste Program, December 14, 2018. Vermont is among a relatively small number of states that have invested in routine measurement of its statewide waste composition, having initiated this time series research dating back to 2012. The state has effectively established an ability to monitor trends and use the data in policy analysis and system planning.

1. INTRODUCTION

- **Section 1 – Introduction:** The remainder of this section provides reported Vermont waste generation and the results of the gate surveys, which were used to allocate waste generation by generator sector. This section also summarizes the waste characterization methodology (i.e., for MSW, C&D, and MRF residue composition).
- **Section 2 – MSW Composition:** The composition of residential and Industrial/Commercial/Institutional (ICI) waste, as well as the Vermont statewide MSW Composition profile, is presented in this section. These results are based on two seasons of field data collection and are highly comparable to the 2018 Study methodology and results.
- **Section 3 – C&D/Bulky Composition:** The results of the visual volumetric composition analysis of C&D and bulky wastes are presented here. New to the 2023 C&D/Bulky characterization methodology, the 2023 Study incorporated a tablet-based computer app that provides real-time density-to-weight conversion. The Project Team believes that this advancement in visual surveying increases the accuracy of visual surveying of this material.
- **Section 4 – Analysis of Vermont Waste Composition:** This chapter synthesizes the results of the preceding two chapters by aggregating the MSW and C&D waste composition results into a Vermont statewide aggregate solid waste composition. Further, this section draws from the MSW composition results to estimate recycling recovery rates (sometimes called capture rates) for mandatory recyclables and for food scraps.
- **Section 5 – MRF Residue Composition:** Given that the primary function of a MRF is to recover recyclable materials, the residues ejected from MRFs should be predominantly non-targeted, non-recyclable materials. However, process inefficiencies and the degradation of recyclables during collection and processing can result in loss of yield for targeted recyclables. This new (i.e., not performed in 2018) research task evaluated the composition of MRF residues from two Vermont single-stream MRFs.
- **Section 6 – Residential Food Scrap Management Questionnaire:** This task was designed to update a similar questionnaire performed in 2018. The 2018 WCS relied on a conventional random selection of Vermont residential households to answer questions about their food scrap management. However, due to changes in communication norms since 2018, the 2023 Study relied on a statistically representative panel of Vermont households to serve as a proxy for the state. The updated methodology and results of the questionnaire are described in this section.
- **Section 7 – Organics (Food Scrap) Management Transportation Questionnaire:** Vermont requires all transporters who transport food scraps for compensation to be permitted as a condition of providing organics transportation services in the state. DEC was interested in better understanding the condition of food scraps (i.e., loose/source separated, or contained in packaging) and capturing the universe of outlets for food scraps, including animal feed, compost, depackaging machine, anaerobic digester, and possibly even food rescue. Although most of these transporters deliver organics to reporting solid waste processing facilities, it is known that some organics may be transported to either out of state or to non-reporting entities like farms or food rescue organizations. This section describes the methodology and findings of this new (i.e., not performed in 2018) questionnaire of food scrap transporters and generators.
- **Section 8 – Direct-to-Broker Recycling:** While the majority of recyclables are collected by haulers and delivered to processors and end users, a subset of recyclables is backhauled or sold directly to a broker or end market by the generating entity. This section describes the methods and findings of an updated attempt to identify and quantify this so-called “economic” recycling activity for materials like cardboard, other paper fibers, plastic/glass/metal containers, plastic film (e.g., pallet wrap, overwrap, bags), and other materials that do not go to a registered processor and are therefore not captured in state tonnage reports.

The report includes the following Appendices that contain supplemental information:

- **Appendix A – Study Design:** Prior to deploying crews for sampling and sorting in the field, a Study Design was developed with input from DEC. The final study design, which includes detailed material definitions as well as the MSW Consultants Safety and Health Plan, is contained here.
- **Appendix B – Questionnaires:** The Project Team collaborated with DEC to update the research questionnaires used to guide data collection in the various questionnaire tasks. The final questionnaire instruments are included here.
- **Appendix C – Detailed Results of Residential Food Scrap Management Questionnaire:** The detailed questionnaire report, which was performed by the University of New Hampshire’s Survey Center under the management of Project Team member DSM, is included in this Appendix. There is a wealth of additional data contained in this report.

1.3 WASTE GENERATION

1.3.1 REPORTED DISPOSAL

DEC maintains an annual reporting system to track the amount and types of solid waste generated and disposed in Vermont. This state-level data is a critical building block of the 2023 Study research and is used as a basis for reporting the composition of all waste streams.

Table 1-1 lists the most recently reported tonnage sent for disposal by Vermonters, specifically for calendar year 2022, including exported wastes. Most wastes are reported as being MSW; however, this sum is known to include C&D debris that gets mixed together during the transfer and transportation process.

Table 1-1 2022 Reported Vermont Waste Generation

Type of Waste	Tons	Percent
Municipal Solid Waste (MSW)	465,054 ^[1]	95.8%
Construction and Demolition (C&D) Debris	20,469 ^[2]	4.2%
Total	485,523	100.0%

^[1] Includes 63,858 tons MSW disposed out of state.

^[2] Includes 12,128 tons C&D disposed out of state.

As shown in this table, there is currently no means of discerning residential MSW from ICI MSW; nor can C&D mixed in with the MSW be segregated. Consequently, this study, like the 2018 Study, relied on selected gate surveying of the reported MSW at Vermont disposal facilities to gain insight into the split of these generator sectors and material streams within MSW.

1.3.2 GATE SURVEY OF MSW LOADS

The gate survey for the 2023 Study was like the 2018 Study surveying insofar as it provided an updated basis for allocating inbound MSW by generator sector. The gate survey tracked key data including truck type, hauler, generator sector and other data needed to develop waste disposal estimates by generator sector. The Project Team reviewed disposal tonnage by facility throughout Vermont, and ultimately selected and recruited facilities (in conjunction with DEC staff) to host the gate survey effort. The specific objective of the gate survey was to differentiate between:

- **Residential** – defined as waste brought to DEC permitted facilities by commercially or municipally operated vehicles, in which 80% or more of the waste is from single-family and/or multifamily residential sources.

1. INTRODUCTION

- **Institutional/Commercial/Industrial (ICI)** – defined as waste brought to DEC permitted facilities by commercially operated vehicles, in which 80% or more of the waste is from institutional, commercial, or industrial sources.
- **Unacceptable Loads** – Loads that contain less than 80% of either residential or ICI waste, and loads originating from outside of Vermont, were omitted from sample selection. Note that in some cases where the majority of loads entering a facility were mixed residential and commercial and it was impossible to obtain a sufficient number of samples of residential or ICI loads from trucks with over 80 percent of the designated material, a decision could be made by the Field Supervisor, after discussions with the truck driver, to sample from the portion of the load which the driver indicates is primarily residential or ICI waste.
- **C&D/Bulky Loads** – Loads that contain 80 percent or more of material generated from construction and demolition activities. It may also include “dry waste loads” which are primarily bulky waste loads managed as C&D loads.

All gate surveying was performed in advance of field work, so that the results could be used to inform the final sampling plan. It should be noted that the extent of gate surveying in the 2023 Study was meaningfully lower compared to the 2018 Study. This is reflected in Table 1-2, which identifies the duration of gate surveying in both studies, as well as the facilities surveyed. The lower level of gate surveying in 2023 was predicated on a consensus between DEC and the Project Team that waste generation and waste flows do not change extensively over time, and that the results of the 2018 gate survey were likely to still be reasonably accurate for purposes of this research. Although not shown in the table, the facilities selected for the 2023 Study were included primarily because they receive the highest tonnages of inbound, Vermont-generated wastes; and, to obtain geographic representation from the different regions of Vermont.

Table 1-2 Summary of Gate Surveys

Region	Facilities	2018 Survey Days	2023 Survey Days
CSWD	All Cycle Transfer Station	4	1
Central	Central VT Transfer Station	3	1
CSWD	Burlington Transfer Station	2	
NEK	NEWSVT Direct Landfill	2	1
Rutland	Gleason Road Transfer Station	2	1
Addison	Addison Transfer Station	2	
Windham	Brattleboro Transfer Station	1	
NW	Highgate Transfer Station	1	
SW	TAM Transfer Station	1	
Lamoille	Hyde Park Transfer Station	1	
SW	Manchester Transfer Station	1	
Total		20	4

Table 1-3 provides the results of the MSW gate surveys from the 2023 Study. As shown, MSW is almost evenly split between the residential and ICI generator sectors. Note that the gate survey also identified the bulky waste (such as waste couches, carpets, mattresses, home goods, etc.) fraction of each generator type.

Table 1-3 MSW Gate Survey Results

Material Stream	Gate Survey Results	2022 Tons
Residential MSW	43.6%	202,719
Bulky	2.3%	10,472
All Other	41.3%	192,247
ICI MSW	37.7%	175,323
Bulky	0.5%	2,106
All Other	37.2%	173,217
C&D	18.7%	87,012
Total	100.0%	465,054

The MSW gate survey results were used to adjust reported generated MSW and C&D tons as shown in Table 1-4. This table also shows the material quantities from the 2018 Study for reference. The percent C&D that was found to be coming in (18.7 percent) is applied to the total MSW generation to adjust tons from MSW to C&D. The tonnage allocation of each waste type is reasonably similar between the two studies. Given the general consistency of results, this report uses the 2023 adjusted tons as the basis for applying composition results in subsequent sections.

Table 1-4 2023 Adjusted Vermont Waste Generation (Tons)

Type of Waste	2023				2018	
	Reported Tons	Gate Survey Adjustments	Adjusted Tons	Percent	Adjusted Tons	Percent
Municipal Solid Waste (MSW)	465,054	-87,012	378,042	77.9%	411,285	80.2%
Construction and Demolition (C&D) Debris	20,469	87,012	107,481	22.1%	101,760	19.8%
Total	485,523	0	485,523	100.0%	513,045	100.0%

Figure 1-1 provides a visual comparison of the statewide proportion of MSW and C&D waste disposal in 2018 and 2022. This table highlights the consistency of disposal allocation between these two waste streams.

1. INTRODUCTION

Figure 1-1 Comparison of MSW and C&D Disposal, 2018 vs. 2023

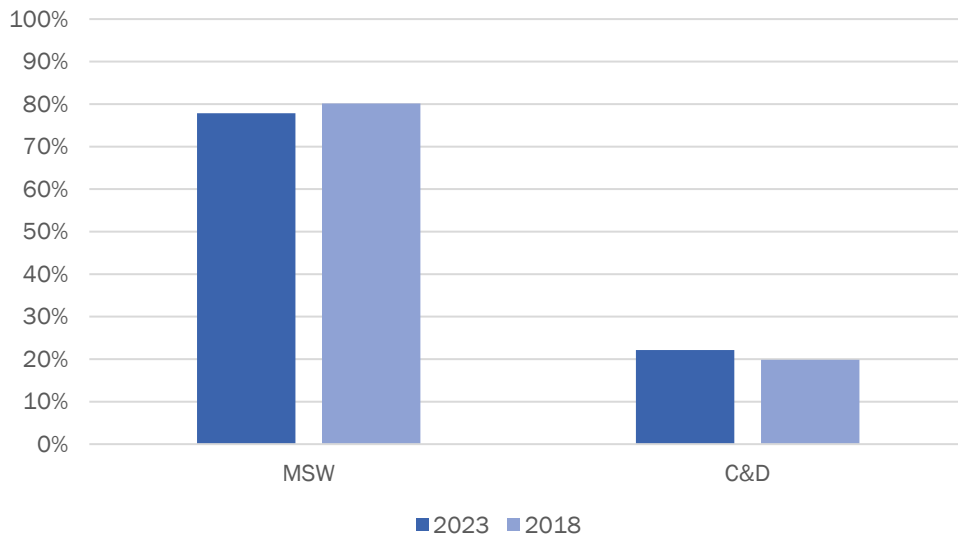

1.4 WASTE COMPOSITION METHODOLOGY SUMMARY

Key components of the waste composition methodology are summarized here. The full study design is attached as Appendix A.

- **Host Facilities** – Figure 1-2 displays the landfill, MRFs, transfer stations, and C&D recycling facilities from which data was gathered for the study. As shown, the host facilities were geographically distributed around the state.

Figure 1-2 Map of Disposal and Recycling Facilities Targeted for Study

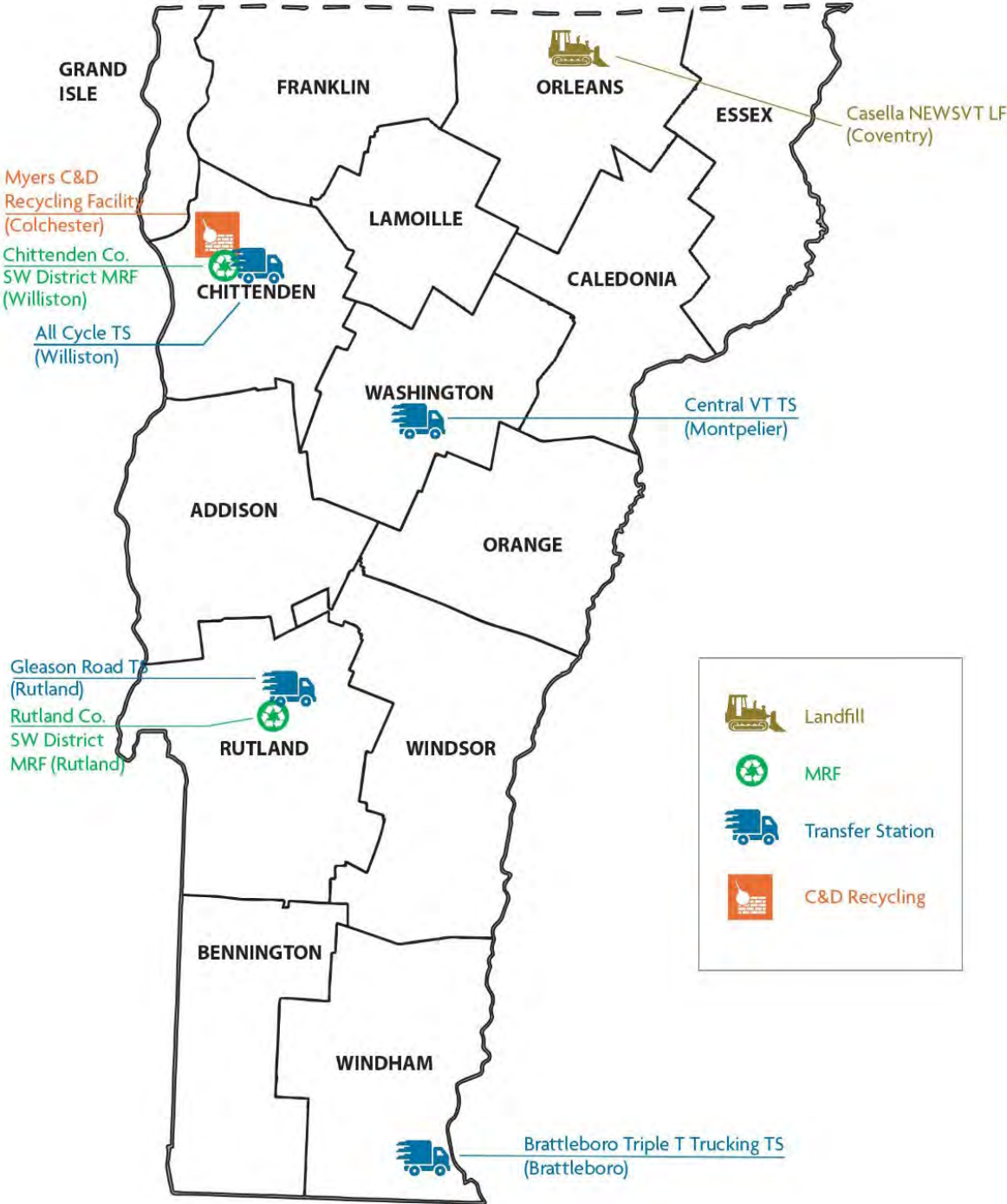

- **Field Data Collection Schedule** – Table 1-5 summarizes the field data collection schedule from the 2023 Study. As shown, data were collected over two seasons, representative of late spring (June) and late summer (September).

1. INTRODUCTION

Table 1-5 Field Data Collection Schedule (CY23)

Project Phase	Facility	Season 1	Season 2
Hand Sorts – MSW Refuse	All-Cycle Transfer Station, Williston	June	
	Brattleboro Transfer Station, Brattleboro		September
	Casella NEWSVT Landfill, Coventry	June	
	Gleason Road Transfer Station, Rutland		September
Hand Sorts - MRF Residues	Rutland County SWD MRF, Rutland		September
	Chittenden County SWD MRF, Williston		September
C&D Visuals	Myers C&D Recycling Facility, Colchester	June	September
	All-Cycle Transfer Station, Williston		September
	Casella NEWSVT Landfill, Coventry	June	

- **MSW Sample Weights:** Consistent with the 2018 Study and with industry standards (ASTM D 5231-92 (2016)), MSW samples were targeted to fall between 200 to 250 pounds. The combined weight of material sorted was 37,554 pounds, for an average of 209 pounds of refuse per sample.
- **C&D Visual Load Surveying:** For loads of C&D debris, a volumetric survey was performed on the entire load. Visual survey methods are described in Appendix A.
- **MSW Sample Targets:** Table 1-6 shows the planned MSW sampling targets as well as the actual MSW samples taken for each facility and generating sector. As shown, sampling targets were met (albeit with a one-sample discrepancy, which does not impact the accuracy of the estimated composition).

Table 1-6 Sample Summary for Hand Sorts of MSW

Season	Facility	Residential Samples		ICI Samples		Total MSW Samples	
		Planned	Actual	Planned	Actual	Planned	Actual
1	All-Cycle Transfer Station, Williston	22	24	23	21	45	45
	Casella NEWSVT Landfill, Coventry	23	28	22	17	45	45
2	Gleason Road Transfer Station, Rutland	23	19	22	26	45	45
	Brattleboro Transfer Station, Brattleboro	22	18	23	27	45	45
Total		90	89	90	91	180	180

- **C&D and Bulky Visual Survey Targets:** Table 1-7 shows the planned C&D sampling targets as well as the actual C&D samples taken for each facility and generating sector. It was decided after the first season that most C&D/Bulky materials received at the landfill were already mixed loads arriving in transfer trailers. Therefore, it was decided to conduct season 2 samples at the All-Cycle Transfer Station. As shown, total sampling targets were met.

1. INTRODUCTION

Table 1-7 Sample Summary for Visual Surveys of C&D Loads

Facility	Season 1 Surveys		Season 2 Surveys		Total	
	Planned	Actual	Planned	Actual	Planned	Actual
Casella NEWSVT Landfill, Coventry	15-25	15			15-25	15
All-Cycle Transfer Station, Williston			15-25	26	15-25	26
Myers C&D Recycling Facility, Colchester	15-25	33	15-25	25	30-50	58
Total	30-50	48	30-50	51	60-100	99

- MRF Residue Sample Targets and Sample Weights:** MRFs generate residue (i.e., non-recovered) wastes at multiple points during processing, with each MRF having their own customized setup to manage residue. For example, some points may drop directly into a bunker to be moved while others may go directly into a compactor. Table 1-8 provides the sampling guidance established for the MRF residue sorts. As shown, a total of 97 samples of MRF residue from various ejection points at the two host MRFs were ultimately obtained, exceeding the targeted number.

Table 1-8 Sample Summary for Hand Sorts of MRF Residue

Residue Type	Notes on Material Origin	Sample Size/Weight	No. of Samples per Facility	Total Samples
Pre-sort Line	Positive sort of oversize reject materials	100-200 lbs.	12-15	24-30
End-of-line Residues	Negative sort	50-100 lbs.	12-15	24-30
Glass Residue	Negative sort	2-gal to 5-gal bucket	5-8	10-16
Other Residues	Misc locations	Varies, probably <50 lbs.	0-8	0-16
Total Planned			29-46	58-92
Actual Samples Obtained				97

- MSW Material Categories and Divertibility Classes:** The final list of MSW materials that were analyzed in the study are shown in Table 1-9. Detailed definitions are contained in Appendix A.⁴ This table also highlights the potential divertibility of each material category. It is important to note that "divertibility" pertains to the material disposition by the generator at discard, and not from the perspective of the receiving facility (landfill, MRF, etc.) For each material, the table indicates whether that material was:
 - Mandated Recyclable:** items banned from the trash and acceptable for placement in the area's "blue bin" recycling collection program. (Note: this excludes #5 polypropylene (PP) plastic containers which are not banned from trash but are widely recycled in Vermont).
 - Mandated Organic:** items that are banned from trash like food waste, leaf and yard debris, and clean wood and generally accepted in composting programs throughout the state.

⁴ The Project Team is aware that some of this project was funded through a SWIFR grant from the U.S. Environmental Protection Agency (EPA). We are also aware that the EPA is funding other, similar research in other states. In the opinion of the Project Team, there is value in standardizing some aspects of the state-level waste composition measurement that is being funded. Vermont may wish to proactively engage EPA and encourage the standardization of the material categories, minimum sampling targets, and material streams to be targeted by similar grant funded projects. EPA would be wise to guide its grant awardees towards parallel data collection, which would result in greater standardization, and therefore higher value of the data being captured from the distributed funding.

1. INTRODUCTION

- **Potentially Divertible:** items that are not mandated, although may be accepted in the local “blue bin” recycling or organics collection programs or may be taken to specific outlets for recycling or reuse. Diversion options may only exist in specific regions in Vermont.
- **Non-Divertible:** all remaining materials that are not currently collected in the recycling and organics programs in Vermont and do not otherwise have a local diversion outlet.
- **Bottle Bill Coverage:** Beverage containers observed in the MSW hand sorts were further subdivided into three groups according to the applicability of the current and potential future bottle bills.
 - **Bottle Bill (BB):** Beverage bottles and cans currently covered by the Vermont bottle bill. Includes carbonated non-alcoholic beverages including sodas, sparkling waters and juices, and carbonated sports and energy drinks; beer, wine coolers, other malt beverages, and pre-mixed spirit cocktails; as well as liquor and spirits. Excludes rice milk, soy milk, milk and dairy. These include categories 11a, 12a, 13a, 25a, and 30a listed in Table 1-9.
 - **Expanded Bottle Bill (EBB):** Beverage bottles and cans not currently covered by the Vermont bottle bill but would be included in an expansion of the bottle bill which would include non-carbonated water, wine, alcoholic hard cider, and juice bottles as well as non-carbonated energy drinks. Excludes rice milk, soy milk, milk and dairy. These include categories 11b, 12b, 13b, 25b, and 30b listed in Table 1-9.
 - **Non-Bottle Bill (NBB):** Beverage bottles and cans not currently covered by the Vermont bottle bill or any expansion of the bottle bill (such as milk containers). This category also includes many containers that are not beverages like shampoo bottles, soy sauce bottles, condiment bottles, that may be glass, plastic or even metal (e.g. sesame oil metal “bottle”). These include categories 11c, 12c, 13c, 25c, and 30c listed in Table 1-9.
- **MRF Residue Material Categories:** A smaller, more targeted subset of material categories was used for the MRF residue sorts. These categories are shown in Table 1-10, with detailed definitions contained in Appendix A. MRF residues were evaluated for divertibility classes as shown in Table 1-10.
- **C&D/Bulky Material Categories:** Material categories for C&D/Bulky wastes are shown in Table 1-11. Detailed definitions are contained in Appendix A. C&D/Bulky material was also evaluated for the divertibility classes as shown in Table 1-11.

Table 1-9 Material Categories & Divertibility Classes – MSW Hand Sorts





Material Category	Material Category
Paper	Organics
1 OCC & Kraft Paper	32 Food Waste - Contained in Packaging
2 Boxboard (Chipboard)	33 Food Waste - Unpackaged
3 Newsprint	34 Branches & Stumps >1"
4 Mixed Recyclable Paper	35 Leaves, Grass, & Brush <1"
5 Magazines/Catalogs	36 Wood - Clean
6 High Grade Office Paper	37 Pet Waste
7 Polycoated/Aseptic Containers	38 Other Organics
8 Books	Electronics
9 Compostable Paper	39 Banned - Non-CED Electronics
10 Remainder/Composite Paper	40 CEDs - CRTs
Plastic	41 CEDs - Computer Peripherals
11 #1 PET Bottles	42 CEDs - Desktop Computers
a #1 PET Bottles - BB	43 CEDs - Laptops/Tablets
b #1 PET Bottles - EBB	44 CEDs - Printers
c #1 PET Bottles & Jars - NBB	45 CEDs - Television/Monitors (Non-CRT)
12 #2 HDPE Bottles	46 Products with Embedded Batteries
a #2 HDPE Bottles - BB	47 Small Appliances
b #2 HDPE Bottles - EBB	48 White Goods
c #2 HDPE Bottles & Jars - NBB	Household Hazardous Waste
13 #3 - #7 Bottles	49 Batteries - Lead Acid
a #3 - #7 Bottles - BB	50 Batteries - Primary
b #3 - #7 Bottles - EBB	51 Batteries (Rechargeable)
c #3 - #7 Bottles & Jars- NBB	52 Mercury Containing Products - Lamps
14 #5 PP Food Containers	53 Mercury Containing Products - Thermostats
15 #6 PS Rigid Food/Beverage Containers	54 Mercury Containing Products- Other
16 #6 EPS Food/Beverage Containers	55 Paint
17 Bulky Rigid Plastics > 1 Gallon	56 Other HHW
18 Plastic Thermoforms	Construction & Demolition
19 Film - Agriculture & Marine Shrink Wrap	57 Asphalt, Brick and Concrete (ABC)
20 Film - Retail Bags	58 Asphalt Shingles
21 Film - Garbage Bags	59 C&D Metal
22 Film - Other Bags	60 Drywall/Gypsum Board
23 Film - Other - Non-Bag	61 Oriented Strand Board
24 Remainder/Composite Plastic	62 Other/Residual C&D
Metal	63 Wood - Painted and Treated
25 Aluminum Beverage Cans	64 Plywood
a Aluminum Beverage Cans - BB	65 Carpet & Carpet Padding
b Aluminum Beverage Cans - EBB	Special/Other
26 Aluminum Foil, Pans, and Non-Bottles	66 Diapers/Sanitary Products
27 Ferrous Containers	67 Fines/Dirt/Mixed Residue
28 Other Ferrous	68 Furniture/Bulky Items
29 Other Non-Ferrous	69 Rubber
Glass	70 Textiles and Leather
30 Glass Beverage Bottles	71 Tires
a Glass Beverage Bottles - BB	All Other Waste
b Glass Beverage Bottles - EBB	72 All Other Wastes Not Elsewhere Categorized
c Glass Bottles & Jars - NBB	
31 Other Glass	
Mandated Recyclable	
Mandated Organic	
Non-Divertible	
Potentially Divertible through Special Statewide or Regional Recycling Collections	

1. INTRODUCTION

Table 1-10 Material Categories & Divertibility Classes – MRF Residue Hand Sorts

Material Category	
Paper	Glass
1 OCC	19 Glass Bottles & Jars
2 Boxboard (chipboard)	Metal
3 Mixed Recyclable Paper	20 Aluminum Cans
4 Polycoated/Aseptic Containers	21 Aluminum Foil, Pans, and Containers
5 Compostable Paper	22 Ferrous Containers
6 Remainder/Composite Paper	23 Other Ferrous
Plastic	24 Other Non-Ferrous
7 #1 PET Bottles & Jars	Organics
8 #1 PET Other Containers	25 Food Waste
9 #2 HDPE Bottles & Jars	Household Hazardous Waste
10 #2 HDPE Other Containers	26 Batteries
11 #3 PVC	27 Other HHW
12 #5 PP Bottles & Jars	Other Waste
13 #5 PP Other Containers	28 All Other Wastes Not Elsewhere Categorized
14 #6 PS Rigid Food/Beverage Containers	29 2-Inch Minus Materials
15 #6 Expanded Polystyrene (EPS)	30 Bagged Materials
16 Bulky Plastic	
17 Film Plastic	
18 Other Rigid Plastic	
 Mandated Recyclable	 Non-Divertible at MRF
 Mandated Organic (Non-Divertible at MRF)	 Potentially Divertible at MRF

Table 1-11 Material Categories & Divertibility Classes – C&D/Bulk Visual Survey

Material Category	Material Category
Paper	Glass
1 OCC (Old Corrugated Cardboard) & Kraft	23 Glass
2 Remainder & Composite Other Paper	Organics
Plastic	24 Yard Waste
3 #1 PET Bottles	25 Food Waste
4 Clean Recoverable Film	26 Remainder & Composite Other Organics
5 HDPE Buckets	Construction & Demolition
6 Remainder & Composite Other Plastic	27 Asphalt Paving
Metal	28 Asphalt Shingles
7 Aluminum Beverage Cans	29 Carpet/Padding
8 HVAC Ducting	30 Ceiling Tiles
9 Non-Ferrous	31 Clean Dimensional Lumber
10 Other Ferrous	32 Clean Gypsum Board
Special Waste	33 Clean OSB
11 Appliances/White Goods	34 Concrete/Brick/Rock
12 Batteries - Lead Acid	35 Dirt/Sand/Gravel
13 Bulky Items	36 Insulation
14 Products with Embedded Batteries	37 Other Clean Engineered Wood
15 Electronics	38 Painted/Stained Wood
16 Items with CRTs	39 Treated Wood
17 Tires	40 Pallets/Crates
18 Mercury Containing Products	41 Plywood
19 Other HHW	42 Wood Furniture
20 Paint	43 Remainder & Composite Other C&D
21 Vehicle and Equipment Fluids	
All Other Waste	
22 All Other Wastes not Elsewhere Categorized	
 Mandated Recyclable	 Non-Divertible
 Mandated Organic	 Potentially Divertible

- Field Data Collection:** The selection of inbound vehicles for sampling, as well as the grab sampling, visual surveying, and sorting methods, followed industry standards and were consistent with the prior study. Details about load selection, sampling and sorting are contained in the Study Design in Appendix A and are not repeated here. However, pictures of MRF residue and manual sorting are featured in Figure 1-3 and Figure 1-4. Pictures from C&D/Bulky visual surveying activity are included in Figure 1-5.

1. INTRODUCTION

Figure 1-3 MRF Residue Hand Sort



		
<p>Retrieval of Residue sample from End-of-Line Compactor</p>	<p>Tipping Floor for Incoming Materials</p>	<p>Retrieval of Sample from Container Line Residue Ejection Point</p>

Figure 1-4 MSW Hand Sort



		
<p>Station for Taking MSW Sample from Wheel Loader Bucket</p>	<p>Crew Handsorting MSW Sample</p>	<p>MSW Sample Staged for Sorting</p>

Figure 1-5 C&D/Bulky Visual Survey

		
<p>Tipped Load of Construction Debris</p>	<p>Roll-off Tipping Load of Bulky</p>	<p>Trailer Dumping Renovation Materials</p>

- Data Recording:** MSW Consultants uses the industry’s only tablet-based app for all field data collection. The data logging app records attributes for inbound loads selected for sampling and manages the pre-weigh and sorted weigh-out process for each sample. By providing real-time sample tallying (including conversion of visual volumetric C&D/Bulky loads to weights based on real-time density conversion), field team members can immediately identify and rectify errors associated with

out-of-spec sample weights. The tablet synchronizes with the cloud via cellular signal or Wifi, providing excellent data security.

- **Statistical Analysis:** Consistent with the 2018 Study, the following statistical measures were calculated to convey the overall composition of MSW hand sorts, MRF residue hand sorts, and C&D/Bulky waste visual surveys.
 - **Sample Mean:** The sample mean, or average, composition is considered the “most likely” fraction for each material category in the waste stream.
 - **Standard Deviation:** The standard deviation measures how widely the values within the data set are dispersed from the sample mean. A higher standard deviation denotes higher variation in the underlying samples for each material, while a lower standard deviation reflects lower variation among the individual samples. (Standard deviations are not presented in the results but are needed in the calculation of the margin of error.)
 - **Margin of Error:** The margin of error (MOE) is a measure of the accuracy of the sample mean and is reported as a single value and measured at a 90 percent level of confidence. (The MOE can be used to determine confidence intervals, which is a statistical concept that indicates the likely range within which the true value lies. Although not reported directly in this report, confidence intervals can be calculated by subtracting (lower interval) and adding (upper interval) the MOE to the sample mean. Confidence intervals reflect the upper and lower range within which the population mean can be expected to fall.)
- **Consideration for Future Studies:** It should be noted that Vermont has consistently evolved and improved its research protocols for characterizing the state’s waste stream. Given the pace of change to packaging and other waste generating influences, the state’s statutory requirement to perform waste characterization studies every five years is well founded and future studies should maintain the methodology that has been successfully applied for this and the prior research cycle.

1. INTRODUCTION

This page is intentionally left blank.

2. MUNICIPAL SOLID WASTE COMPOSITION

2.1 AGGREGATE MSW COMPOSITION

This section presents the results of the composition analysis of MSW conducted in the 2023 Study and compares selected results with the 2018 Study. Results are presented predominantly in percentage terms, although the same graphics can be readily converted to present results measured by tonnage. The aggregate MSW (i.e., residential and ICI combined) results are presented first, followed by results by generator sectors.

Figure 2-1 shows the breakdown of aggregate MSW by material group. Consistent with the 2018 Study, and with other recently performed statewide studies, organics, paper, and special/other are the most prevalent materials being disposed in landfills or incinerators. Note that C&D represents the percent of C&D type materials identified within the loads of MSW, excluding loads that are primarily C&D.

Figure 2-1 2023 Aggregate MSW Composition by Material Group

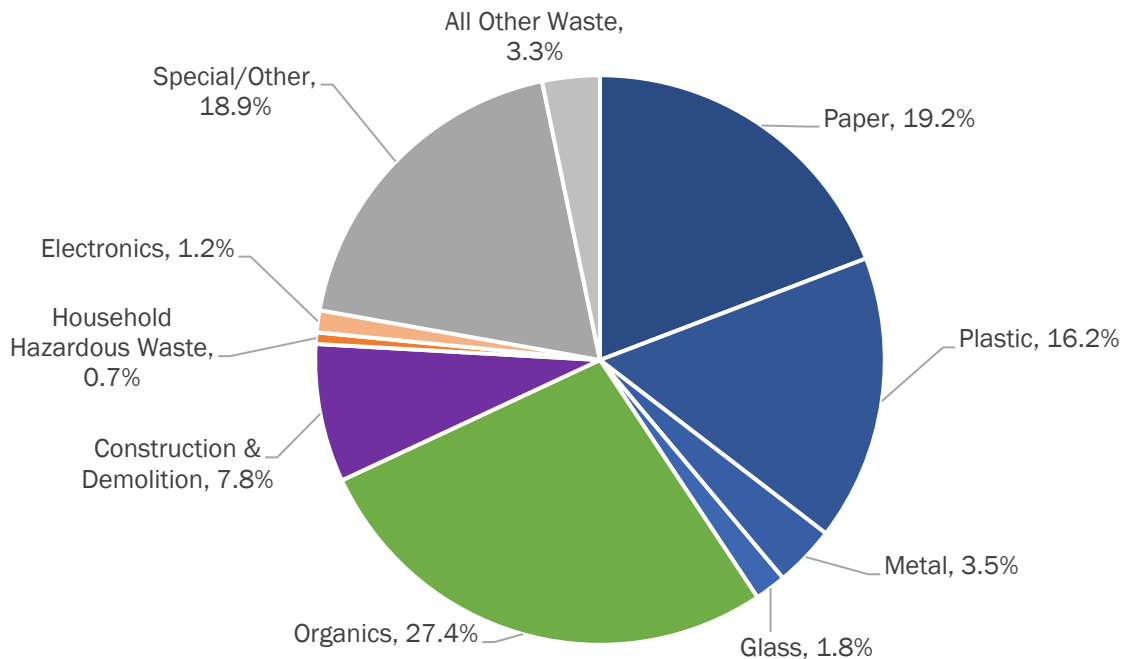

Figure 2-2 recasts the results of the previous figure with greater detail into the composition of the special/other and organics waste material groups. In particular, Figure 2-2 calls out some noteworthy individual material categories like food waste, textiles & leather, non-food organics like leaves and pet waste, diapers/sanitary products, and furniture/bulky items.

2. MUNICIPAL SOLID WASTE COMPOSITION

Figure 2-2 2023 Aggregate MSW Composition with Expanded Organics and Special/Other Groups

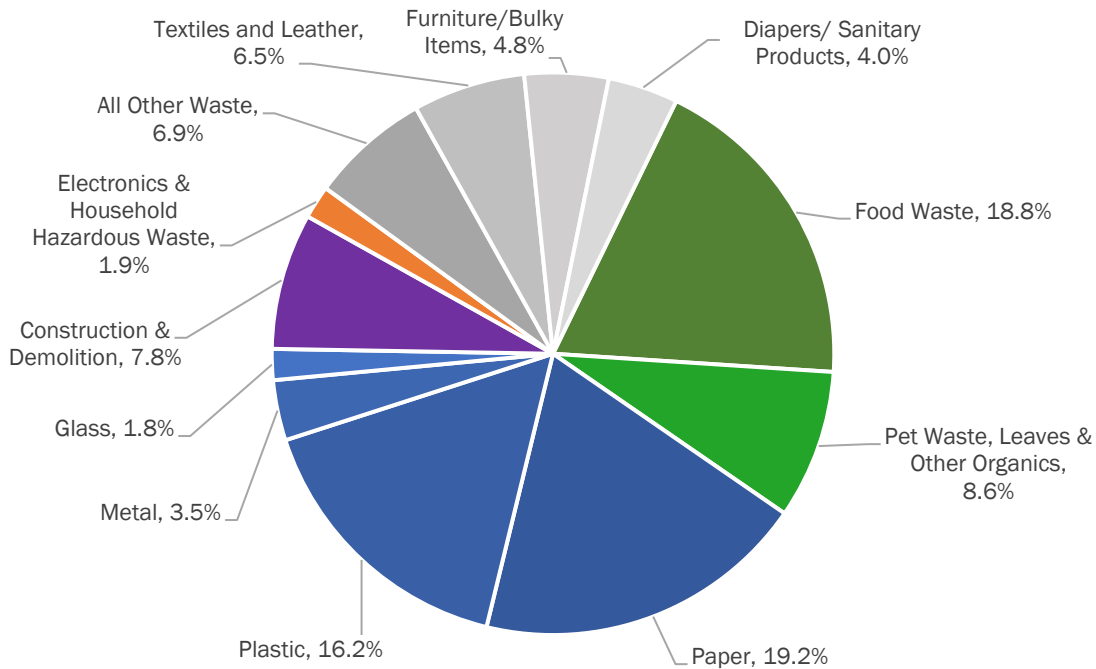

Figure 2-3 compares the aggregate MSW composition by material group for the 2023 and 2018 studies. At a glance, this figure suggests that paper, organics, C&D and special other have decreased, while plastic and metal have increased. However, confidence intervals have been added to this figure—and similar ones that follow—at a 90 percent level of confidence for the 2023 data¹. Confidence intervals have also been added for selected 2018 data points where it was possible to construct the confidence intervals from information contained in the 2018 Study report (i.e., no attempt was made to revisit the 2018 Study data to fill in data gaps in this figure). These indicate instances where the apparent change may not be statistically significant, meaning that the apparent difference between the two samples is likely to be due to random chance. Generally, if confidence intervals do not overlap, the difference between two samples is likely to be significant (i.e. actually different). For example, “special/other” waste (which includes bulky waste like furniture, mattresses, and carpet along with textiles/leather, diapers and sanitary products, and miscellaneous wastes not elsewhere classified) was found to have relatively wide confidence intervals in both 2018 and 2023. Although the estimated mean composition has decreased slightly in 2023 compared to 2018, from a statistical standpoint it is likely that there is no meaningful decrease in the amount of special waste disposed by Vermonters. In contrast, there appears to be significantly more plastic, metal, and other waste in the MSW stream, and less C&D waste than in 2018.

It is important to note that the categorization in this table is focused only on the material group and is silent on the recyclability of any materials. For example, “Paper” in this table includes both unrecyclable and uncompostable paper along with recyclable (cardboard) and compostable paper (paper towels). “Organics - other” includes organic materials including leaves, yard waste, and pet waste. Plastics as a group of materials (including recyclable and non-recyclable) has grown as other groups such as paper,

¹ The organics material group is provided in two material categories to highlight food waste; no confidence interval is provided on these subgroupings.

2. MUNICIPAL SOLID WASTE COMPOSITION

organics - food waste, and C&D have decreased. For more details on defined material groups and specific material categories see Appendix A.

Figure 2-3 Comparison of MSW Composition, 2023 vs. 2018

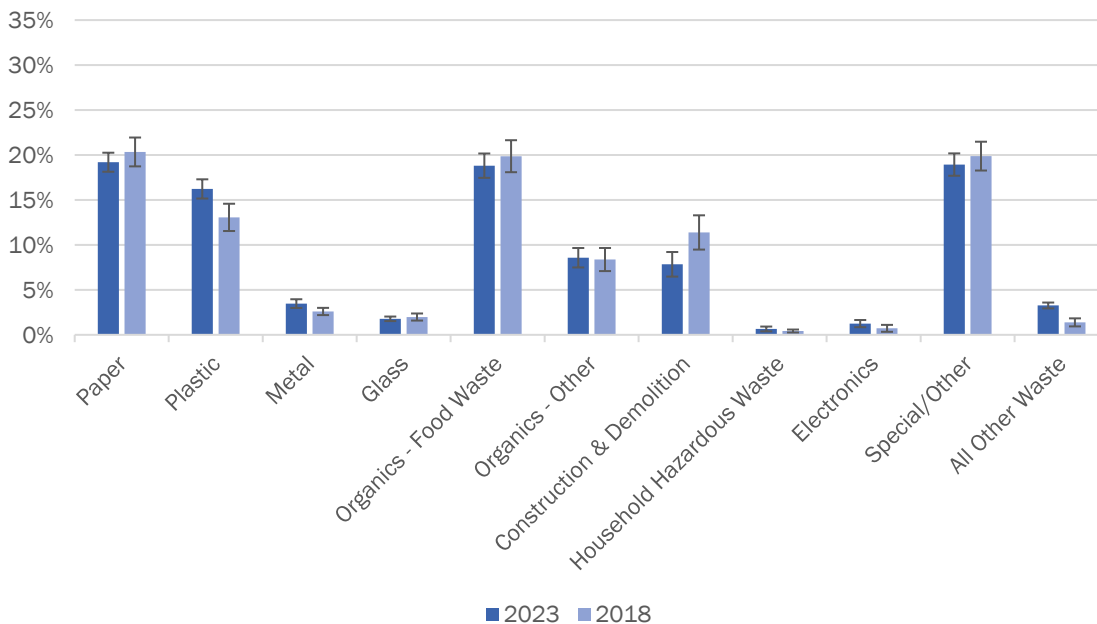

Figure 2-4 compares the incidence of selected material categories between the two studies. As shown, film plastic, other rigid plastic, pet waste, and textiles and leather have seen the largest increases while food waste, other organics, and furniture/bulky items experienced the largest decreases.

2. MUNICIPAL SOLID WASTE COMPOSITION

Figure 2-4 Comparison of Selected Constituents in MSW, 2023 vs. 2018

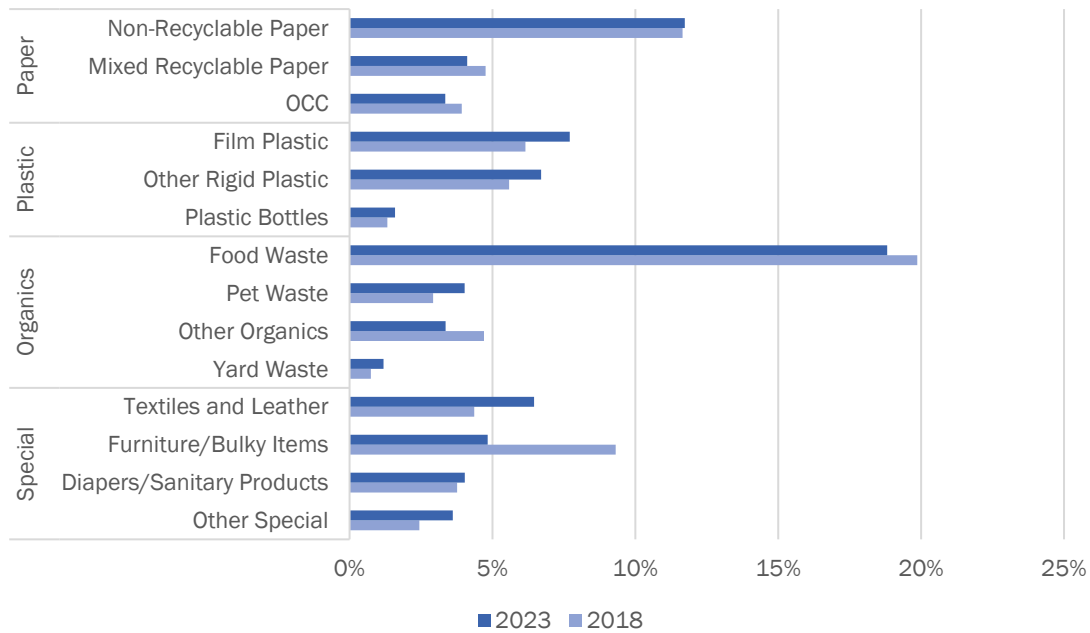

Figure 2-5 presents the 10 most prevalent individual constituents in the aggregate MSW stream. As shown, the two food waste categories are the most prevalent materials, by weight, found in the aggregate MSW stream.

Figure 2-5 Top 10 Constituents in Aggregate MSW

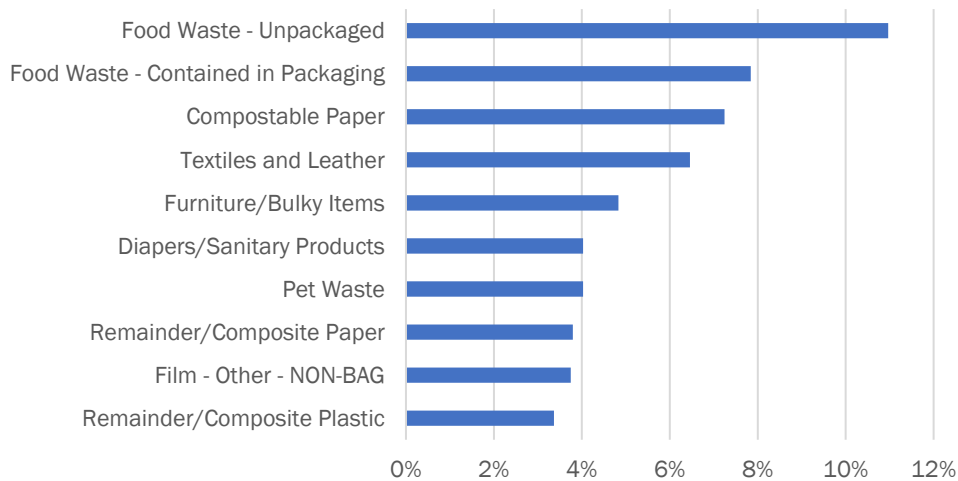
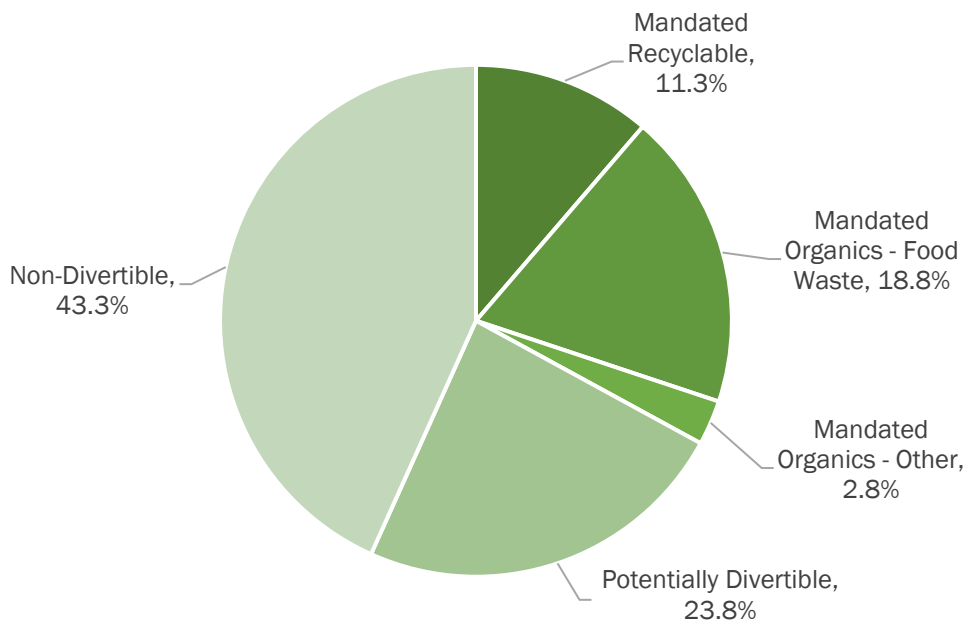

Figure 2-6 recasts the composition results to illustrate the divertibility of disposed MSW (see Table 1-9 for details). As shown, a meaningful fraction of disposed MSW is comprised of mandated organics and mandated recyclables (33 percent combined). Another 24 percent of disposed MSW is potentially divertible. Potentially divertible items include things like scrap metal to scrap recyclers, retail plastic bags returned to store drop-off programs, electronic waste recycling programs, and certain household hazardous materials which should optimally flow to special waste collection.

2. MUNICIPAL SOLID WASTE COMPOSITION

Figure 2-6 Divertibility of MSW in 2023



These fractions represent opportunities for future reduction of waste to landfill. However, it is noteworthy that over 43 percent of MSW is not currently divertible in Vermont. It should further be noted that this graphic omits the impact of contamination (soiled or compromised recyclable material), and as a practical matter it is not possible for all the divertible materials to actually be diverted. For example, newspaper used as bedding for a small pet is too soiled for recycling but would have been classified as newspaper in this study. Unemptied food jars, bottles and cans would be recyclable if they had been emptied and rinsed and would have been emptied to the greatest extent possible and sorted as mandated recyclables in this study. These and other instances of degradation and contamination that occur to otherwise recyclable materials illustrate the various challenges inherent in materials recovery processing and achieving any sort of “perfect” recycling.

Figure 2-7 compares the divertibility of the 2023 aggregate disposed refuse MSW stream with the 2018 Study. As shown, the incidence of mandated recyclables (categories #1-#6, #11-#12, and #25-#27) and mandated organics (categories #34-#36 in Table 2-1) found in the waste stream has declined on a statistically significant basis.

2. MUNICIPAL SOLID WASTE COMPOSITION

Figure 2-7 Comparison of MSW Divertibility, 2023 vs. 2018

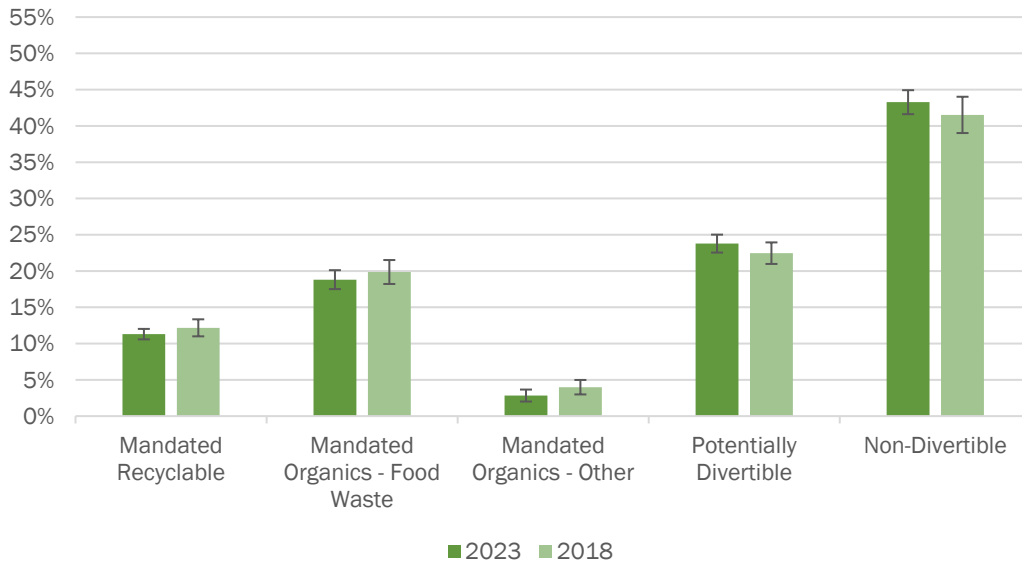

Table 2-1 presents a detailed statistical summary of the composition of disposed MSW in Vermont, calculated at a 90 percent level of confidence. This table shows the sample mean composition percentage, as well as the margin of error (MOE) around the sample mean. The composition percentages were first applied to the non-bulky MSW obtained from the gate survey. Bulky waste tonnages from the gate survey (see Table 1-3) were then manually added to the furniture/bulky items line in this table, and the composition percentages were recalculated to reflect the composition of all 378,042 tons of MSW. The derivation of total tons of MSW is shown in Table 1-4.

2. MUNICIPAL SOLID WASTE COMPOSITION

Table 2-1 Detailed Composition of Aggregate MSW

Material Category	Est.			Tons	Est.			
	Percent	MOE			Percent	MOE	Tons	
Paper	19.2%	1.1%		72,563	Electronics	1.2%	0.4%	4,719
1 OCC & Kraft Paper	3.3%	0.5%		12,658	39 Banned - Non-CED Electronics	0.2%	0.1%	575
2 Boxboard (Chipboard)	1.1%	0.1%		4,311	40 CEDs - CRTs	0.0%	0.0%	0
3 Newsprint	0.3%	0.1%		1,182	41 CEDs - Computer Peripherals	0.0%	0.0%	26
4 Mixed Recyclable Paper	2.3%	0.3%		8,755	42 CEDs - Desktop Computers	0.0%	0.0%	0
5 Magazines/Catalogs	0.2%	0.1%		728	43 CEDs - Laptops/Tablets	0.0%	0.0%	80
6 High Grade Office Paper	0.2%	0.1%		590	44 CEDs - Printers	0.0%	0.0%	0
7 Polycoated/Aseptic Containers	0.3%	0.0%		1,081	45 CEDs - Television/Monitors (Non-CRT)	0.0%	0.0%	105
8 Books	0.4%	0.2%		1,523	46 Products with Embedded Batteries	0.0%	0.0%	100
9 Compostable Paper	7.2%	0.5%		27,385	47 Small Appliances	0.8%	0.3%	2,926
10 Remainder/Composite Paper	3.8%	0.6%		14,349	48 White Goods	0.2%	0.2%	907
Plastic	16.2%	1.1%		61,338	Household Hazardous Waste	0.7%	0.3%	2,469
11 #1 PET Bottles	0.9%	0.0%		3,556	49 Batteries - Lead Acid	0.0%	0.0%	0
12 #2 HDPE Bottles	0.6%	0.1%		2,139	50 Batteries - Primary	0.1%	0.0%	251
13 #3 - #7 Bottles	0.1%	0.0%		329	51 Batteries (Rechargeable)	0.0%	0.0%	1
14 #5 PP Food Containers	0.8%	0.3%		3,130	52 Mercury Cont. Products - Lamps	0.0%	0.0%	7
15 #6 PS Rigid Food/Beverage Containers	0.1%	0.0%		219	53 Mercury Cont. Products - Thermostats	0.0%	0.0%	0
16 #6 EPS Food/Beverage Containers	0.2%	0.1%		839	54 Mercury Cont. Products- Other	0.0%	0.0%	2
17 Bulky Rigid Plastics > 1 Gallon	1.6%	0.4%		6,030	55 Paint	0.2%	0.1%	644
18 Plastic Thermoforms	0.9%	0.1%		3,240	56 Other HHW	0.4%	0.2%	1,563
19 Film - Agriculture/Marine Shrink Wrap	0.3%	0.2%		1,285	Construction & Demolition	7.8%	1.4%	29,646
20 Film - Retail Bags	0.1%	0.0%		299	57 Asphalt, Brick and Concrete (ABC)	0.0%	0.0%	115
21 Film - Garbage Bags	2.6%	0.2%		9,826	58 Asphalt Shingles	0.4%	0.3%	1,627
22 Film - Other Bags	0.9%	0.2%		3,557	59 C&D Metal	0.1%	0.1%	286
23 Film - Other - Non-Bag	3.7%	0.3%		14,166	60 Drywall/Gypsum Board	0.3%	0.2%	1,119
24 Remainder/Composite Plastic	3.4%	0.6%		12,724	61 Oriented Strand Board	0.1%	0.1%	275
Metal	3.5%	0.5%		13,125	62 Other/Residual C&D	2.4%	0.7%	8,915
25 Aluminum Cans	0.4%	0.0%		1,545	63 Wood - Painted and Treated	1.6%	0.5%	6,169
26 Aluminum Foil, Pans, and Containers	0.5%	0.0%		1,710	64 Plywood	0.8%	0.3%	2,889
27 Ferrous Containers	0.5%	0.1%		1,771	65 Carpet & Carpet Padding	2.2%	0.7%	8,251
28 Other Ferrous	1.4%	0.3%		5,467	Special/Other	18.9%	1.3%	71,578
29 Other Non-Ferrous	0.7%	0.2%		2,633	66 Diapers/Sanitary Products	4.0%	0.6%	15,233
Glass	1.8%	0.3%		6,734	67 Fines/Dirt/Mixed Residue	2.8%	0.3%	10,517
30 Glass Bottles	1.0%	0.0%		3,777	68 Furniture/Bulky Items	4.8%	1.8%	18,271
31 Other Glass	0.8%	0.2%		2,957	69 Rubber	0.5%	0.2%	1,974
Organics	27.4%	1.5%		103,524	70 Textiles and Leather	6.5%	0.8%	24,413
32 Food Waste - Contained in Packaging	7.8%	0.8%		29,650	71 Tires	0.3%	0.3%	1,171
33 Food Waste - Unpackaged	11.0%	0.9%		41,462	All Other Waste	3.3%	0.3%	12,346
34 Branches & Stumps >1"	0.0%	0.0%		113	72 All Other Waste Not Elsewhere Classified	3.3%	0.3%	12,346
35 Leaves, Grass, & Brush <1"	1.2%	0.5%		4,376				
36 Wood - Clean	1.6%	0.7%		6,235				
37 Pet Waste	4.0%	0.7%		15,226	Total	100.0%		378,042
38 Other Organics	1.7%	0.4%		6,463	Samples	180		
Mandated Recyclable	11.3%			42,721	Non-Divertible	43.3%		163,588
Mandated Organic	21.6%			81,836	Potentially Divertible	23.8%		89,897

Table 2-2 provides the absolute and relative composition of aluminum, glass and plastic bottles and cans according to their classification within Vermont's bottle bill (see Table 1-9). The "Absolute Percent" column shows the percentage of each material in the Aggregate MSW, and the "Relative Percent" column shows the percentages that a bottle or can makes up out of only that material type (e.g. #1 PET Bottles – BB is 11.3% of all #1 PET Bottles). The final four rows show the absolute and relative percents for all

2. MUNICIPAL SOLID WASTE COMPOSITION

Bottle Bill, Extended Bottle Bill, and Non-Bottle Bill bottles and cans combined. The breakout of materials shown and also in Figure 2-8 represents a subsort completed for material categories #11, #12, #13, #25, and #30 in Table 2-1. Full definitions of the subsort materials are included in Appendix A.

Table 2-2 Breakdown of Bottles and Cans in Aggregate Disposed MSW

Material Subsorts	Absolute Pct	Relative Pct	Tons
#1 PET Bottles	0.9%	100.0%	3,556
#1 PET Bottles - BB	0.1%	11.3%	402
#1 PET Bottles - EBB	0.6%	62.7%	2,229
#1 PET Bottles (and Jars) - NBB	0.2%	26.0%	925
#2 HDPE Bottles	0.6%	100.0%	2,139
#2 HDPE Bottles - BB	0.0%	0.4%	9
#2 HDPE Bottles - EBB	0.1%	25.4%	542
#2 HDPE Bottles (and Jars) - NBB	0.4%	74.2%	1,587
#3-7 Bottles	0.1%	100.0%	329
#3 - #7 Bottles - BB	0.0%	3.4%	11
#3 - #7 Bottles - EBB	0.0%	2.4%	8
#3 - #7 Bottles (and Jars) - NBB	0.1%	94.2%	309
Glass Bottles	1.0%	100.0%	3,777
Glass Bottles - BB	0.4%	35.6%	1,345
Glass Bottles - EBB	0.4%	42.0%	1,588
Glass Bottles (and Jars) - NBB	0.2%	22.3%	844
Aluminum Cans	0.4%	100.0%	1,545
Aluminum Cans - BB	0.3%	83.5%	1,291
Aluminum Cans - EBB	0.1%	16.5%	254
Total	3.0%	100.0%	11,345
<i>Total BB</i>	<i>0.8%</i>	<i>27.0%</i>	<i>3,058</i>
<i>Total EBB</i>	<i>1.2%</i>	<i>40.7%</i>	<i>4,621</i>
<i>Total NBB</i>	<i>1.0%</i>	<i>32.3%</i>	<i>3,665</i>

Figure 2-8 visualizes the results in Table 2-2. This figure highlights two important details about the disposal of bottle bill materials²:

- Bottles and cans observed in the disposed MSW stream are largely non-bottle bill containers. This suggests that bottle bill containers are being effectively recovered through the bottle return system.
- Expansion of the bottle bill system³ would potentially have the largest impact on increasing diversion of additional PET bottles and additional glass bottles, with smaller gains in HDPE bottles. Limited gains would be achieved with aluminum cans and #3-#7 bottles. In all cases, the expanded bottle bill

² Includes carbonated non-alcoholic beverages such as sodas, sparkling waters and juices, and carbonated sports and energy drinks; beer, wine coolers, other malt beverages, and pre-mixed spirit cocktails; as well as liquor and spirits. Excludes rice milk, soy milk, milk, and dairy.

³ Expanded Bottle Bill would include non-carbonated water, wine, alcoholic hard cider, and juice bottles as well as non-carbonated energy drinks. Would still exclude rice milk, soy milk, milk, and dairy.

2. MUNICIPAL SOLID WASTE COMPOSITION

would have a relatively small impact on total diversion of materials if measured by weight.⁴ Also, some expanded bottle bill material would likely still be disposed, as seen with the existing bottle bill.

Figure 2-8 Bottle and Can Composition in Aggregate MSW

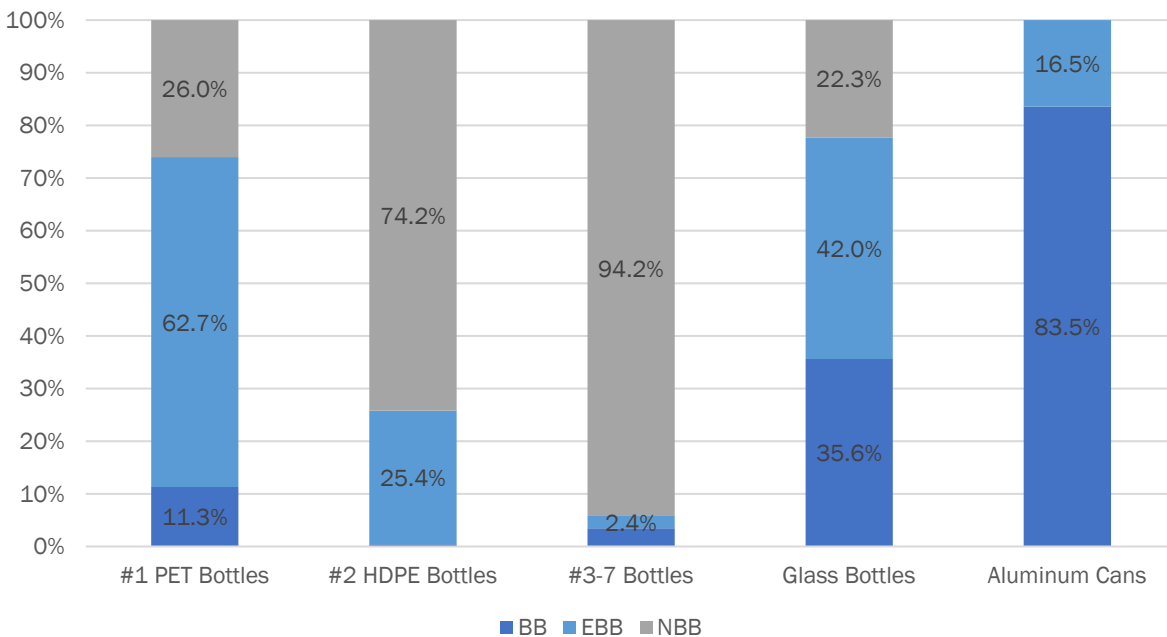

2.2 RESIDENTIAL COMPOSITION

This section focuses on the results of the residential composition analysis. The figures and tables follow the presentation of the aggregate MSW composition in the previous section. Further, comparative data are presented for the 2023 and 2018 Studies.

Figure 2-9 presents the residential MSW composition in 2023 and compares these results with the 2018 Study. If the two organics categories are added together, they continue to comprise the largest fraction of the disposed residential waste stream, by weight, followed by special/other, paper, and plastics.

⁴ While the volume of lightweight but high-volume containers and material type are important considerations, it was beyond the scope of this project to measure and analyze by volume.

2. MUNICIPAL SOLID WASTE COMPOSITION

Figure 2-9 Comparison of Residential MSW Composition by Material Group, 2023 vs. 2018

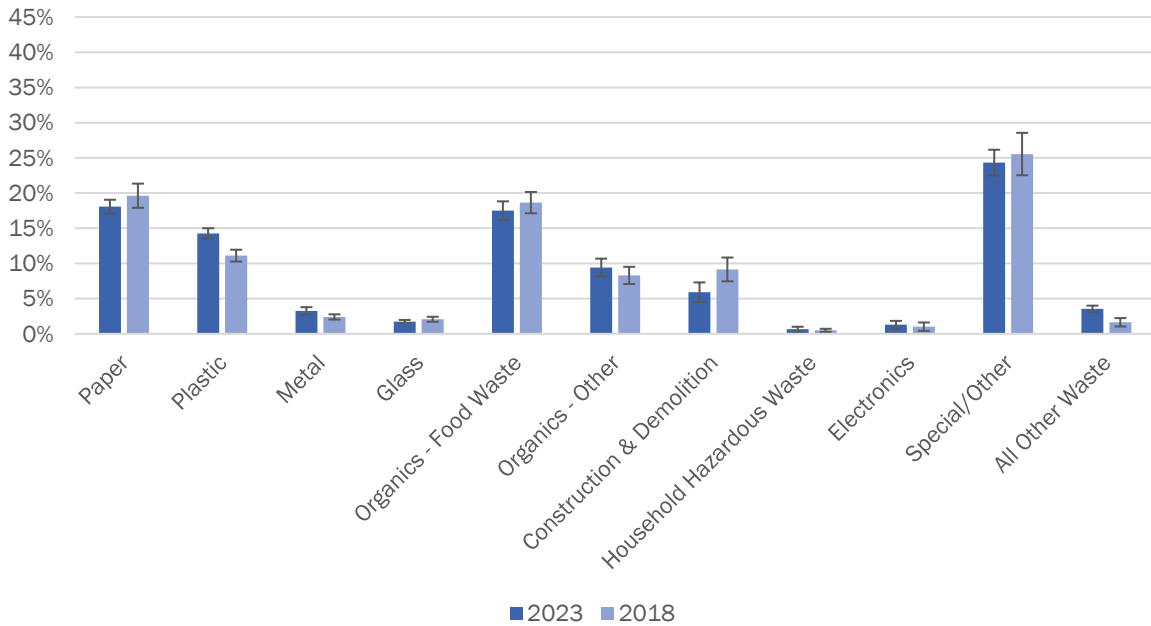

Figure 2-10 compares the divertibility of the residential disposed refuse stream with the 2018 Study. The graphic shows slight decreases in both mandated recyclables and mandated organics found in the waste stream, which is consistent with the aggregate MSW stream.

Figure 2-10 Comparison of Residential MSW Divertibility, 2023 vs. 2018

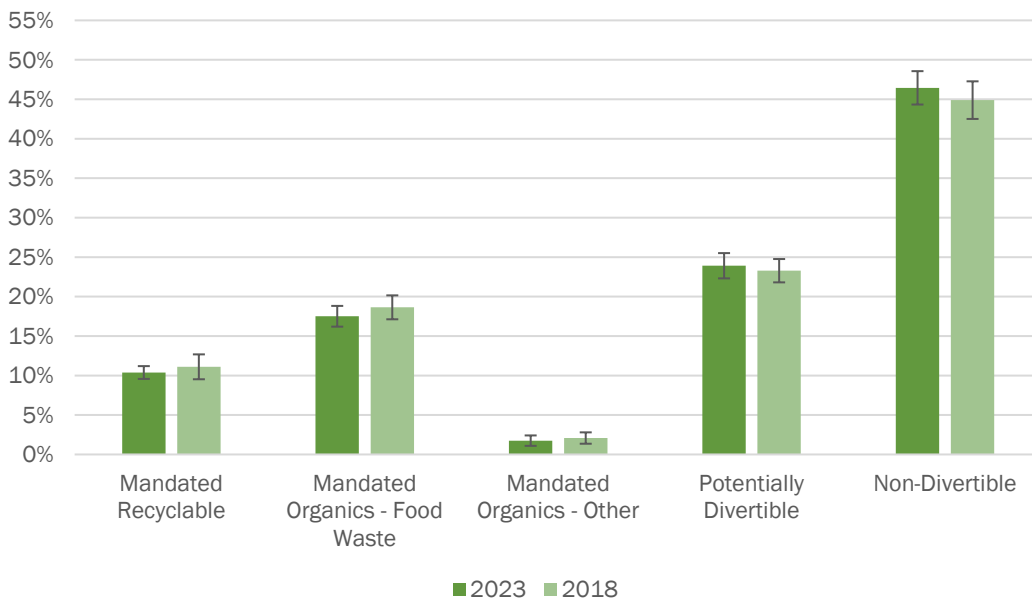

Table 2-3 presents a detailed statistical summary of the composition of disposed MSW in the residential sector in Vermont. The resulting composition includes 10,472 tons of bulky waste from the gate survey

2. MUNICIPAL SOLID WASTE COMPOSITION

added to the furniture/bulky items line in order to characterize all 202,719 tons of residential MSW that were disposed in Vermont. (The derivation of residential tons of MSW is shown in Table 1-3.)

Table 2-3 Detailed Composition of Residential MSW

Material Category	Est.				Est.		
	Percent	MOE	Tons		Percent	MOE	Tons
Paper	18.1%	1.0%	36,627	Electronics	1.3%	0.6%	2,634
1 OCC & Kraft Paper	2.3%	0.6%	4,561	39 Banned - Non-CED Electronics	0.2%	0.1%	434
2 Boxboard (Chipboard)	1.2%	0.2%	2,334	40 CEDs - CRTs	0.0%	0.0%	0
3 Newsprint	0.4%	0.2%	790	41 CEDs - Computer Peripherals	0.0%	0.0%	19
4 Mixed Recyclable Paper	2.4%	0.3%	4,813	42 CEDs - Desktop Computers	0.0%	0.0%	0
5 Magazines/Catalogs	0.2%	0.1%	487	43 CEDs - Laptops/Tablets	0.0%	0.0%	80
6 High Grade Office Paper	0.1%	0.1%	163	44 CEDs - Printers	0.0%	0.0%	0
7 Polycoated/Aseptic Containers	0.3%	0.0%	593	45 CEDs - Television/Monitors (Non-CRT)	0.0%	0.0%	0
8 Books	0.6%	0.4%	1,146	46 Products with Embedded Batteries	0.0%	0.0%	66
9 Compostable Paper	7.3%	0.5%	14,852	47 Small Appliances	0.8%	0.5%	1,664
10 Remainder/Composite Paper	3.4%	0.4%	6,887	48 White Goods	0.2%	0.3%	371
Plastic	14.3%	0.8%	28,912	Household Hazardous Waste	0.7%	0.4%	1,355
11 #1 PET Bottles	0.9%	0.0%	1,919	49 Batteries - Lead Acid	0.0%	0.0%	0
12 #2 HDPE Bottles	0.6%	0.0%	1,236	50 Batteries - Primary	0.1%	0.0%	210
13 #3 - #7 Bottles	0.1%	0.0%	231	51 Batteries (Rechargeable)	0.0%	0.0%	1
14 #5 PP Food Containers	0.6%	0.1%	1,172	52 Mercury Cont. Products - Lamps	0.0%	0.0%	0
15 #6 PS Rigid Food/Beverage Containers	0.1%	0.0%	134	53 Mercury Cont. Products - Thermostats	0.0%	0.0%	0
16 #6 EPS Food/Beverage Containers	0.2%	0.0%	495	54 Mercury Cont. Products- Other	0.0%	0.0%	2
17 Bulky Rigid Plastics > 1 Gallon	1.0%	0.4%	2,059	55 Paint	0.1%	0.2%	266
18 Plastic Thermoforms	0.9%	0.1%	1,755	56 Other HHW	0.4%	0.3%	877
19 Film - Agriculture/Marine Shrink Wrap	0.2%	0.3%	455	Construction & Demolition	5.9%	1.5%	11,984
20 Film - Retail Bags	0.1%	0.0%	218	57 Asphalt, Brick and Concrete (ABC)	0.0%	0.0%	51
21 Film - Garbage Bags	2.5%	0.2%	5,100	58 Asphalt Shingles	0.4%	0.5%	776
22 Film - Other Bags	0.9%	0.1%	1,897	59 C&D Metal	0.1%	0.1%	185
23 Film - Other - Non-Bag	3.5%	0.3%	7,117	60 Drywall/Gypsum Board	0.2%	0.2%	376
24 Remainder/Composite Plastic	2.5%	0.3%	5,125	61 Oriented Strand Board	0.1%	0.0%	107
Metal	3.3%	0.6%	6,592	62 Other/Residual C&D	1.7%	0.6%	3,508
25 Aluminum Cans	0.4%	0.0%	794	63 Wood - Painted and Treated	1.3%	0.6%	2,564
26 Aluminum Foil, Pans, and Containers	0.5%	0.1%	1,099	64 Plywood	0.3%	0.3%	517
27 Ferrous Containers	0.4%	0.1%	899	65 Carpet & Carpet Padding	1.9%	0.9%	3,899
28 Other Ferrous	1.2%	0.4%	2,427	Special/Other	24.3%	1.6%	49,307
29 Other Non-Ferrous	0.7%	0.3%	1,373	66 Diapers/Sanitary Products	5.2%	0.9%	10,488
Glass	1.7%	0.3%	3,532	67 Fines/Dirt/Mixed Residue	3.4%	0.5%	6,815
30 Glass Bottles	1.0%	0.1%	1,951	68 Furniture/Bulky Items	7.0%	1.0%	14,285
31 Other Glass	0.8%	0.1%	1,581	69 Rubber	0.3%	0.2%	690
Organics	26.9%	1.8%	54,595	70 Textiles and Leather	7.9%	1.1%	16,072
32 Food Waste - Contained in Packaging	7.5%	0.8%	15,257	71 Tires	0.5%	0.5%	957
33 Food Waste - Unpackaged	10.0%	0.9%	20,234	All Other Waste	3.5%	0.5%	7,180
34 Branches & Stumps >1"	0.0%	0.1%	85	72 All Other Waste Not Elsewhere Classified	3.5%	0.5%	7,180
35 Leaves, Grass, & Brush <1"	1.3%	0.7%	2,716				
36 Wood - Clean	0.4%	0.2%	744				
37 Pet Waste	5.9%	1.2%	11,986	Total	100.0%		202,719
38 Other Organics	1.8%	0.5%	3,573	Samples			89
■ Mandated Recyclable	10.4%		21,047	■ Non-Divertible	46.5%		94,164
■ Mandated Organic	19.3%		39,036	■ Potentially Divertible	23.9%		48,471

Table 2-4 provides the absolute and relative composition percentages of the bottles and cans found in the residential waste stream with respect to bottle bill legislation as described with Table 2-2. The breakout of materials shown represents a subsort completed for material categories #11, #12, #13, #25, and #30 in Table 2-3. Full definitions of the subsort materials are included in Appendix A. Figure 2-11 provides the

2. MUNICIPAL SOLID WASTE COMPOSITION

same data visually. The mix of bottle bill containers in the residential stream is consistent with the mix in the aggregate waste stream.

Table 2-4 Breakdown of Bottles and Cans in Residential MSW

Material Subsorts	Absolute Pct	Relative Pct	Tons
#1 PET Bottles	0.9%	100.0%	1,919
#1 PET Bottles - BB	0.1%	10.7%	206
#1 PET Bottles - EBB	0.5%	56.8%	1,090
#1 PET Bottles (and Jars) - NBB	0.3%	32.5%	623
#2 HDPE Bottles	0.6%	100.0%	1,236
#2 HDPE Bottles - BB	0.0%	0.5%	6
#2 HDPE Bottles - EBB	0.1%	21.1%	260
#2 HDPE Bottles (and Jars) - NBB	0.5%	78.4%	970
#3-7 Bottles	0.1%	100.0%	231
#3 - #7 Bottles - BB	0.0%	4.5%	10
#3 - #7 Bottles - EBB	0.0%	2.1%	5
#3 - #7 Bottles (and Jars) - NBB	0.1%	93.4%	216
Glass Bottles	1.0%	100.0%	1,951
Glass Bottles - BB	0.3%	26.5%	517
Glass Bottles - EBB	0.4%	40.5%	790
Glass Bottles (and Jars) - NBB	0.3%	33.0%	645
Aluminum Cans	0.4%	100.0%	794
Aluminum Cans - BB	0.3%	85.7%	680
Aluminum Cans - EBB	0.1%	14.3%	114
Total	3.0%	100.0%	6,131
<i>Total BB</i>	<i>0.7%</i>	<i>23.1%</i>	<i>1,419</i>
<i>Total EBB</i>	<i>1.1%</i>	<i>36.8%</i>	<i>2,259</i>
<i>Total NBB</i>	<i>1.2%</i>	<i>40.0%</i>	<i>2,453</i>

2. MUNICIPAL SOLID WASTE COMPOSITION

Figure 2-11 Bottle and Can Composition in Residential MSW

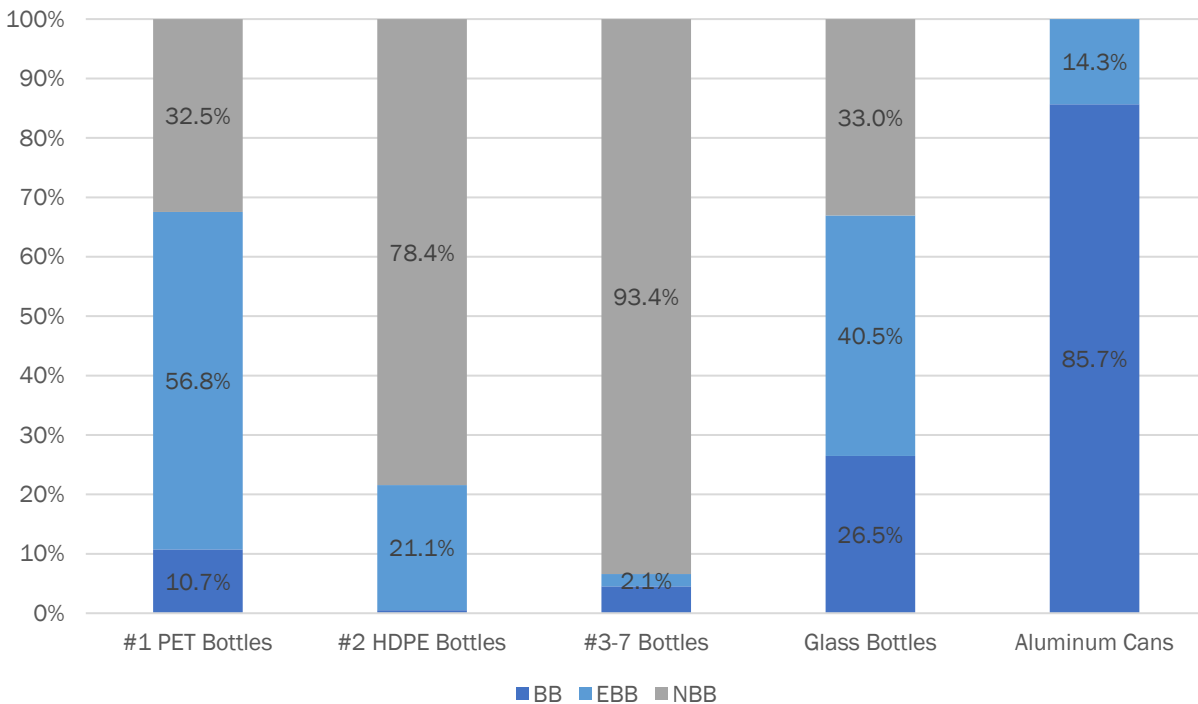

2.3 ICI COMPOSITION

Figure 2-12 shows the composition of ICI MSW by material group, as well as the comparative results from the 2018 Study with confidence levels added. The trend in ICI waste is largely consistent with residential waste.

Figure 2-12 ICI Composition by Material Group, 2023 vs. 2018

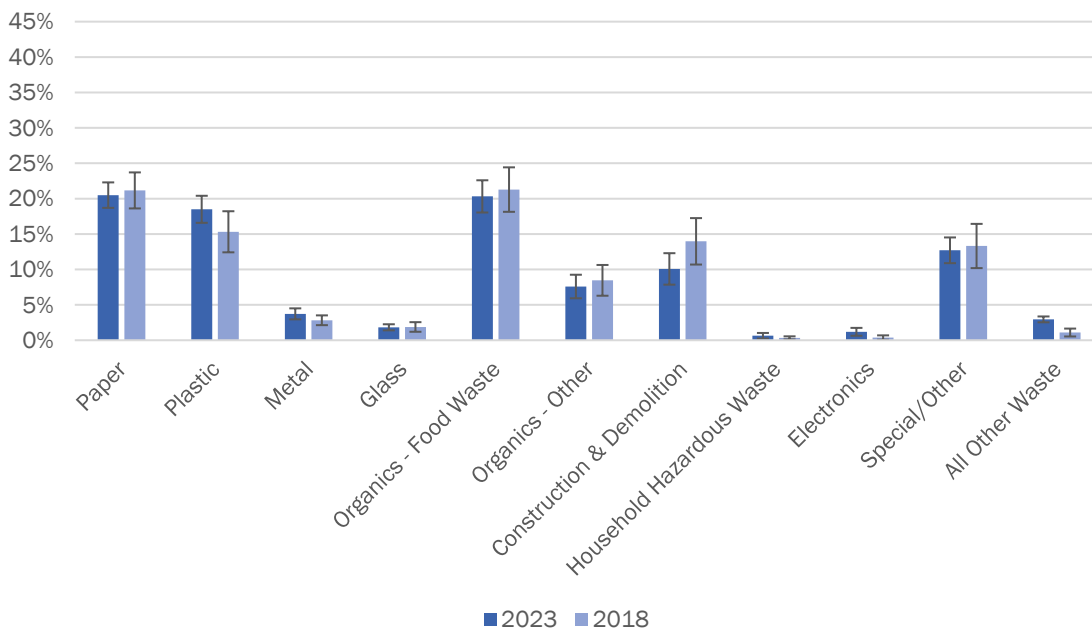

2. MUNICIPAL SOLID WASTE COMPOSITION

Figure 2-13 compares the divertibility of the ICI waste stream with the 2018 study. Trends in the ICI waste stream are consistent with the residential stream, in that all mandated recyclable and organic materials have decreased since 2018.

Figure 2-13 ICI Composition by Divertibility, 2023 vs. 2018

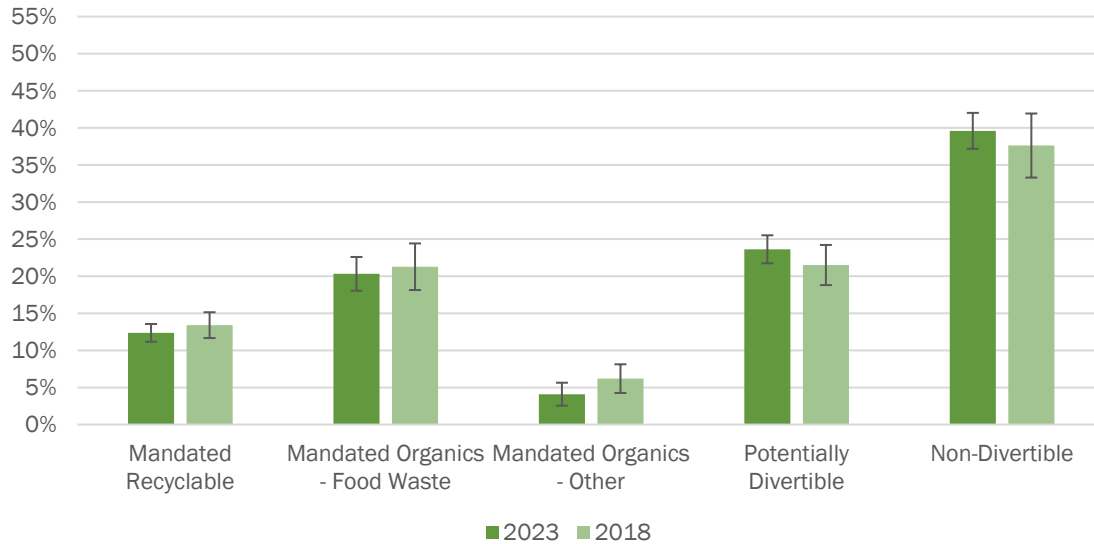

Table 2-5 presents a detailed statistical summary of the composition of disposed MSW in Vermont, calculated at a 90 percent level of confidence. The resulting composition includes 2,106 tons of bulky waste from the gate survey added to the furniture/bulky waste line to account for all 175,323 tons of ICI MSW that were disposed in Vermont.

2. MUNICIPAL SOLID WASTE COMPOSITION

Table 2-5 Detailed Composition of ICI MSW

Material Category	Est.				Est.		
	Percent	MOE	Tons		Percent	MOE	Tons
Paper	20.5%	1.0%	35,936	Electronics	1.2%	0.6%	2,085
1 OCC & Kraft Paper	4.6%	0.9%	8,097	39 Banned - Non-CED Electronics	0.1%	0.0%	141
2 Boxboard (Chipboard)	1.1%	0.2%	1,976	40 CEDs - CRTs	0.0%	0.0%	0
3 Newsprint	0.2%	0.1%	392	41 CEDs - Computer Peripherals	0.0%	0.0%	7
4 Mixed Recyclable Paper	2.2%	0.5%	3,942	42 CEDs - Desktop Computers	0.0%	0.0%	0
5 Magazines/Catalogs	0.1%	0.1%	241	43 CEDs - Laptops/Tablets	0.0%	0.0%	0
6 High Grade Office Paper	0.2%	0.1%	427	44 CEDs - Printers	0.0%	0.0%	0
7 Polycoated/Aseptic Containers	0.3%	0.1%	488	45 CEDs - Television/Monitors (Non-CRT)	0.1%	0.1%	105
8 Books	0.2%	0.2%	377	46 Products with Embedded Batteries	0.0%	0.0%	34
9 Compostable Paper	7.1%	0.9%	12,533	47 Small Appliances	0.7%	0.4%	1,262
10 Remainder/Composite Paper	4.3%	1.2%	7,462	48 White Goods	0.3%	0.4%	536
Plastic	18.5%	0.8%	32,425	Household Hazardous Waste	0.6%	0.4%	1,113
11 #1 PET Bottles	0.9%	0.0%	1,637	49 Batteries - Lead Acid	0.0%	0.0%	0
12 #2 HDPE Bottles	0.5%	0.0%	902	50 Batteries - Primary	0.0%	0.0%	41
13 #3 - #7 Bottles	0.1%	0.0%	98	51 Batteries (Rechargeable)	0.0%	0.0%	1
14 #5 PP Food Containers	1.1%	0.7%	1,958	52 Mercury Cont. Products - Lamps	0.0%	0.0%	7
15 #6 PS Rigid Food/Beverage Containers	0.0%	0.0%	85	53 Mercury Cont. Products - Thermostats	0.0%	0.0%	0
16 #6 EPS Food/Beverage Containers	0.2%	0.1%	343	54 Mercury Cont. Products- Other	0.0%	0.0%	0
17 Bulky Rigid Plastics > 1 Gallon	2.3%	0.8%	3,971	55 Paint	0.2%	0.2%	378
18 Plastic Thermoforms	0.8%	0.2%	1,485	56 Other HHW	0.4%	0.4%	686
19 Film - Agriculture/Marine Shrink Wrap	0.5%	0.4%	830	Construction & Demolition	10.1%	1.5%	17,662
20 Film - Retail Bags	0.0%	0.0%	81	57 Asphalt, Brick and Concrete (ABC)	0.0%	0.0%	64
21 Film - Garbage Bags	2.7%	0.3%	4,725	58 Asphalt Shingles	0.5%	0.5%	851
22 Film - Other Bags	0.9%	0.4%	1,661	59 C&D Metal	0.1%	0.1%	101
23 Film - Other - Non-Bag	4.0%	0.6%	7,049	60 Drywall/Gypsum Board	0.4%	0.4%	743
24 Remainder/Composite Plastic	4.3%	1.1%	7,599	61 Oriented Strand Board	0.1%	0.1%	168
Metal	3.7%	0.6%	6,533	62 Other/Residual C&D	3.1%	1.4%	5,407
25 Aluminum Cans	0.4%	0.0%	751	63 Wood - Painted and Treated	2.1%	0.7%	3,605
26 Aluminum Foil, Pans, and Containers	0.3%	0.1%	610	64 Plywood	1.4%	0.7%	2,372
27 Ferrous Containers	0.5%	0.1%	872	65 Carpet & Carpet Padding	2.5%	1.3%	4,352
28 Other Ferrous	1.7%	0.6%	3,040	Special/Other	12.7%	1.6%	22,271
29 Other Non-Ferrous	0.7%	0.3%	1,259	66 Diapers/Sanitary Products	2.7%	0.8%	4,745
Glass	1.8%	0.3%	3,202	67 Fines/Dirt/Mixed Residue	2.1%	0.4%	3,702
30 Glass Bottles	1.0%	0.1%	1,825	68 Furniture/Bulky Items	2.3%	0.7%	3,986
31 Other Glass	0.8%	0.3%	1,377	69 Rubber	0.7%	0.3%	1,284
Organics	27.9%	1.8%	48,929	70 Textiles and Leather	4.8%	1.1%	8,341
32 Food Waste - Contained in Packaging	8.2%	1.4%	14,394	71 Tires	0.1%	0.2%	213
33 Food Waste - Unpackaged	12.1%	1.8%	21,229	All Other Waste	2.9%	0.5%	5,166
34 Branches & Stumps >1"	0.0%	0.0%	28	72 All Other Waste Not Elsewhere Classified	2.9%	0.4%	5,166
35 Leaves, Grass, & Brush <1"	0.9%	0.9%	1,659				
36 Wood - Clean	3.1%	1.4%	5,490				
37 Pet Waste	1.8%	0.5%	3,240	Total	100.0%		175,323
38 Other Organics	1.6%	0.7%	2,889	Samples			91
Mandated Recyclable	12.4%		21,674	Non-Divertible	39.6%		69,424
Mandated Organic	24.4%		42,800	Potentially Divertible	23.6%		41,426

Table 2-6 provides the absolute and relative composition percentages of the bottles and cans that were found in the ICI waste stream with respect to bottle bill legislation as described with Table 2-2. The breakout of materials shown represents a subsort completed for material categories #11, #12, #13, #25, and #30 in Table 2-5. Figure 2-14 shows the same data visually. The mix of bottle bill containers in the ICI stream is consistent with the mix in the aggregate waste stream.

2. MUNICIPAL SOLID WASTE COMPOSITION

Table 2-6 Breakdown of Bottles and Cans in ICI MSW

Material Subsorts	Absolute Pct	Relative Pct	Tons
#1 PET Bottles	0.9%	100.0%	1,637
#1 PET Bottles - BB	0.1%	11.9%	196
#1 PET Bottles - EBB	0.6%	69.6%	1,139
#1 PET Bottles (and Jars) - NBB	0.2%	18.5%	302
#2 HDPE Bottles	0.5%	100.0%	902
#2 HDPE Bottles - BB	0.0%	0.3%	3
#2 HDPE Bottles - EBB	0.2%	31.2%	282
#2 HDPE Bottles (and Jars) - NBB	0.4%	68.4%	617
#3-7 Bottles	0.1%	100.0%	98
#3 - #7 Bottles - BB	0.0%	0.9%	1
#3 - #7 Bottles - EBB	0.0%	3.0%	3
#3 - #7 Bottles (and Jars) - NBB	0.1%	96.1%	94
Glass Bottles	1.0%	100.0%	1,825
Glass Bottles - BB	0.5%	45.4%	829
Glass Bottles - EBB	0.5%	43.7%	798
Glass Bottles (and Jars) - NBB	0.1%	10.9%	199
Aluminum Cans	0.4%	100.0%	751
Aluminum Cans - BB	0.3%	81.3%	611
Aluminum Cans - EBB	0.1%	18.7%	140
Total	3.0%	100.0%	5,214
<i>Total BB</i>	<i>0.9%</i>	<i>31.4%</i>	<i>1,639</i>
<i>Total EBB</i>	<i>1.3%</i>	<i>45.3%</i>	<i>2,362</i>
<i>Total NBB</i>	<i>0.7%</i>	<i>23.3%</i>	<i>1,212</i>

2. MUNICIPAL SOLID WASTE COMPOSITION

Figure 2-14 Bottle and Can Composition in ICI MSW

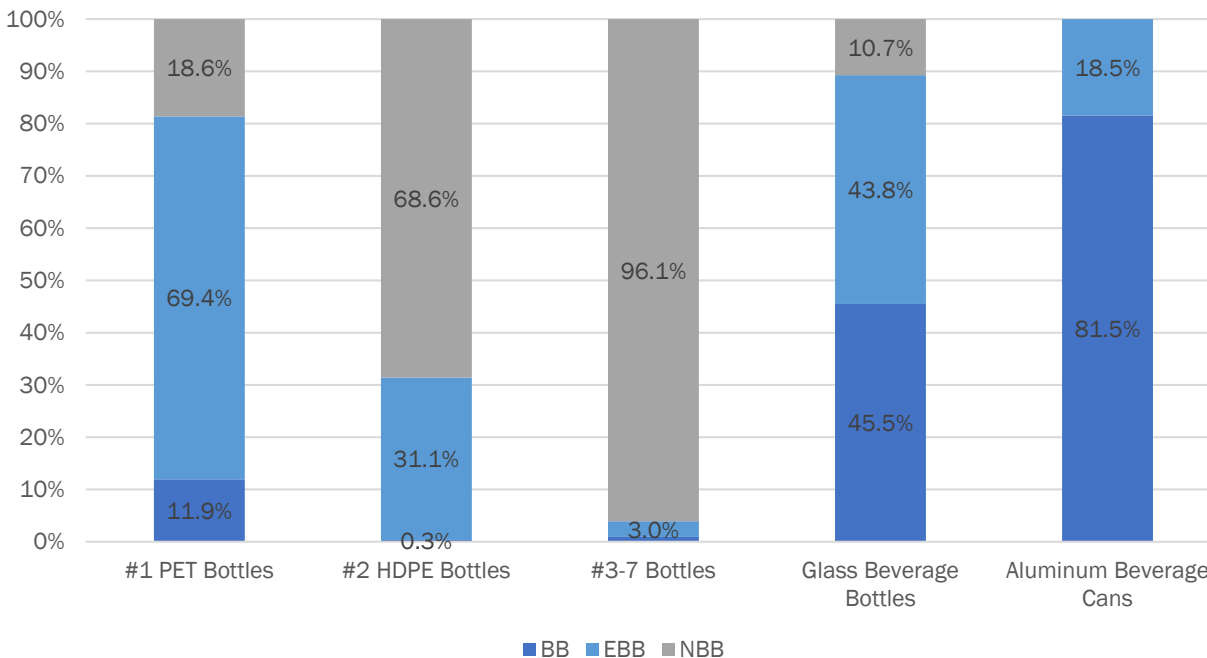

2.4 COMPARISONS OF RESIDENTIAL & ICI WASTE DISPOSAL

This section provides some basic comparisons of residential and ICI wastes in 2023. Figure 2-15 compares the composition by material group in terms of percentage. Although disposed waste composition from the two generating sectors is relatively comparable, some differences are statistically significant, meaning that there are likely some actual differences between the two waste streams. The residential stream contributes less paper, plastics, and C&D, but a significantly higher amount of special/other waste from materials such as diapers/sanitary products, carpet, textiles, and bulky items compared to the ICI stream.

2. MUNICIPAL SOLID WASTE COMPOSITION

Figure 2-15 Residential vs. Commercial MSW Composition

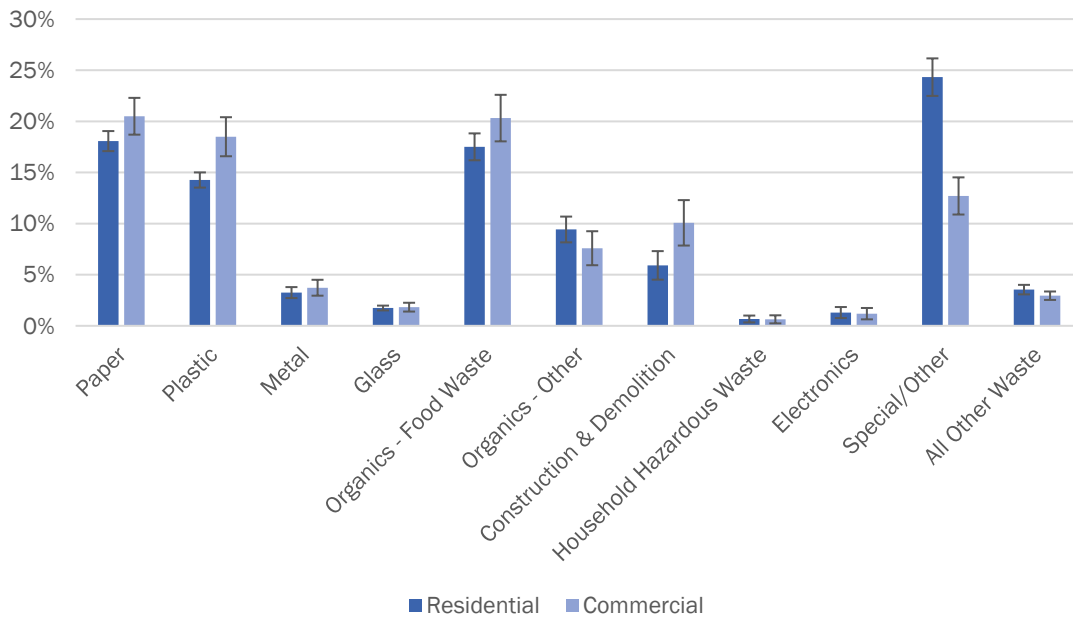
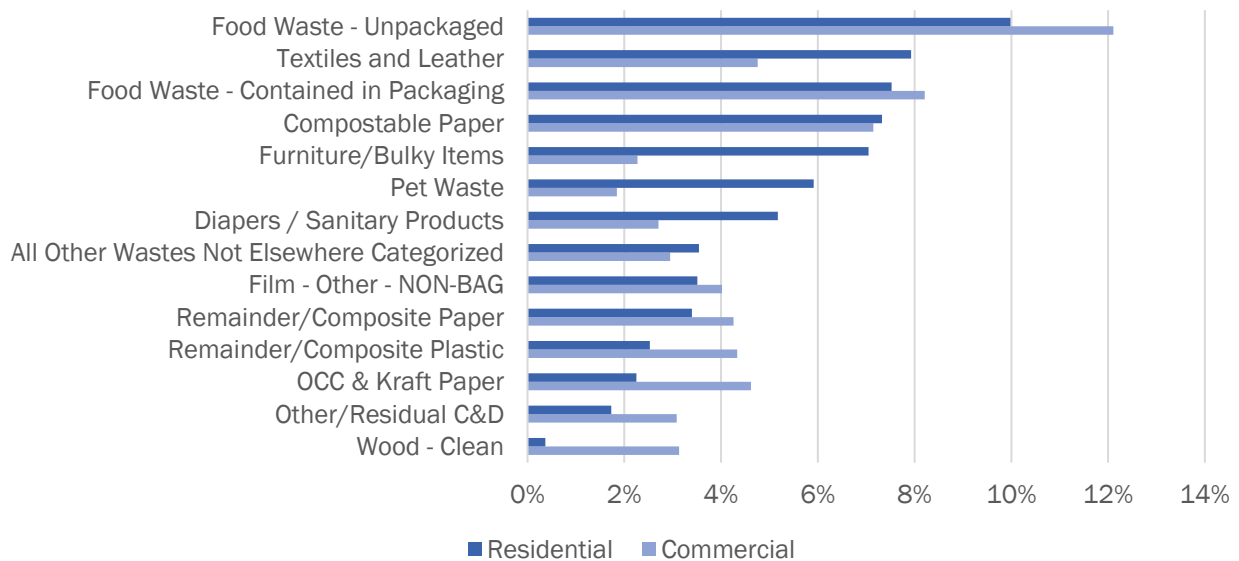

Figure 2-16 compares the top ten material constituents in the residential sector to their respective constituents in the ICI sector. The data in this figure are ordered from largest to smallest in the residential stream. Further, there are more than 10 materials listed because the residential and ICI top 10 materials are not the same. This chart highlights the significantly higher proportion of textiles, furniture/bulky items, pet waste, and diapers in the residential stream compared to the ICI stream. Food waste-unpackaged, remainder/composite plastic, OCC & kraft paper, other/residual C&D, and wood-clean are significantly more present in the ICI stream compared to residential.

Figure 2-16 Residential vs. Commercial Top 10 Constituents



Similarly, Figure 2-17 compares the top ten recyclable materials in the residential sector to the same constituents in the ICI sector. Similar to the preceding figure, the data in this figure are ordered by the

2. MUNICIPAL SOLID WASTE COMPOSITION

residential values, and there are more than 10 materials listed because the residential and ICI top 10 materials are not the same. Consistent with other large-scale waste composition studies performed across the U.S., a significantly higher fraction of recyclable OCC was found in the ICI MSW stream compared to the residential stream. This figure highlights opportunities for improved capture of these materials in recycling programs targeting the residential and ICI sectors.

Figure 2-17 Residential vs. Commercial Top 10 Recyclable Constituents

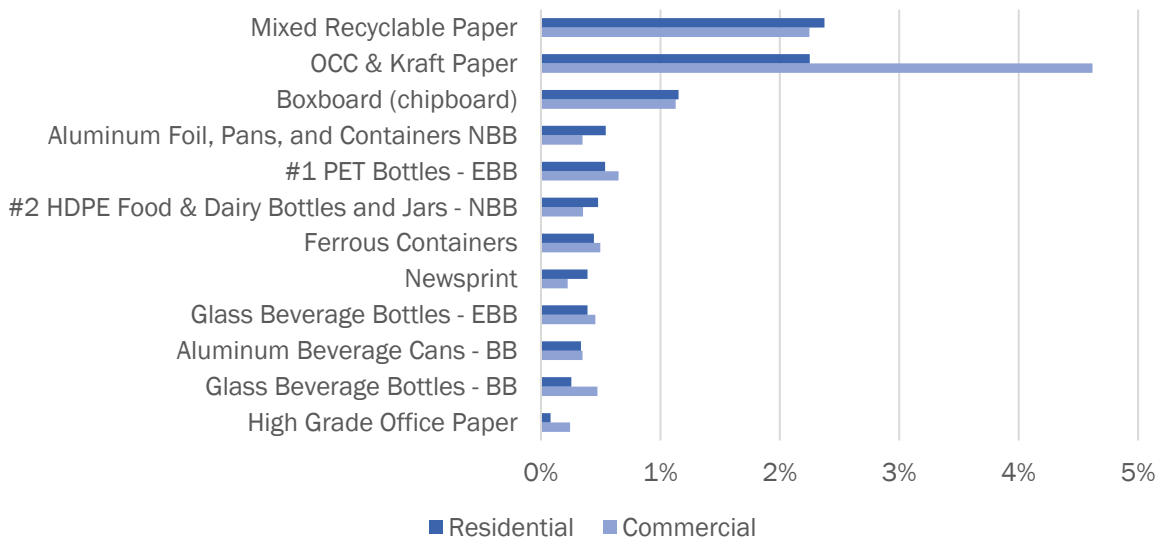

The graphs and tables in this section are intended to highlight noteworthy results of the MSW composition found in this 2023 Study. These results are not intended to comprehensively analyze the MSW stream, but rather serve as a foundation for the state’s solid waste and recycling planners, haulers, facility owners, and other stakeholders to evaluate in the interest of optimizing materials management more fully in Vermont.

2. MUNICIPAL SOLID WASTE COMPOSITION

This page is intentionally left blank.

3. CONSTRUCTION & DEMOLITION WASTE COMPOSITION

3.1 C&D/BULKY WASTE COMPOSITION

This section presents the results of the visual composition analysis of C&D debris in the 2023 Study and compares selected results with the 2018 Study. Results are presented predominantly in percentage terms, although the same graphics can be readily converted to present results measured by tonnage.

It should be noted that Vermont experienced record flooding (historic July 2023 flooding) in the months between season 1 and season 2 of the C&D visual surveys. The state experienced a burst of flood-related debris, much of which would likely be considered bulky or C&D related under normal circumstances. The Project Team’s enumerators proactively interviewed supervisory and tip floor staff as well as drivers at both C&D sites to omit flood-related debris from the study. While it is possible that some flood-related debris slipped through the screening, it is the opinion of the Project Team that the majority of flood cleanup had occurred before season 2, based on facility and driver feedback, and these results are indicative of C&D waste during normal periods of generation. The application of our composition estimates should be appropriate for applying to 2022 tonnage, which would not include any flood debris.

Figure 3-1 summarizes the composition of C&D wastes, using the same material groups as shown in the MSW hand sort composition results. Not surprisingly, over 83 percent of the 107,481 tons of adjusted C&D (Table 1-4) were classified under the C&D group if using MSW material groups.

Figure 3-1 Weight-Based Composition of C&D Waste Based on MSW Material Groups

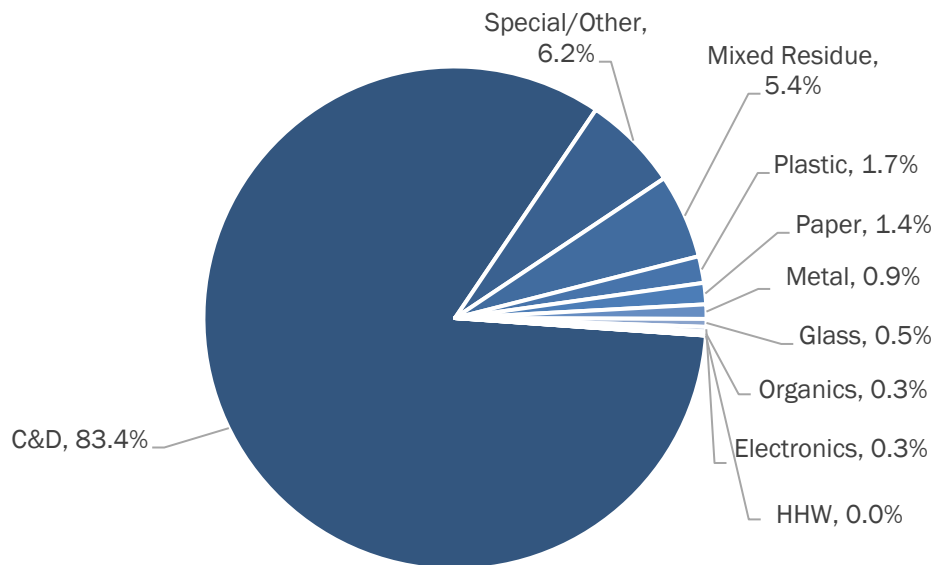

Figure 3-2 recasts the materials into groups that are more reflective of common material types occurring within C&D debris. This figure combines paper, plastic, glass, organics, electronics and HHW into “MSW,” and subdivides the 83.4 percent pie piece in the previous pie chart so that the underlying components of C&D are visible, with the following material category re-groupings:

- **Other C&D:** Includes asphalt paving, carpet/padding, ceiling tiles, clean gypsum board, clean OSB, insulation, and remainder/composite other C&D which includes items such as fixtures, fiberboard, clay pipe, buckets/film/caulking tubes, and electrical wire.

3. CONSTRUCTION & DEMOLITION WASTE COMPOSITION

- **MSW:** Includes various plastics, glass, organics, various HHW materials, and mixed MSW (typically bagged).
- **Bulky:** Includes wood furniture, appliances/white goods, tires, and bulky categories which includes non-wood furniture, mattresses, box springs and other hard to handle items that are not separately classified.
- **Inerts:** Includes concrete/brick/rock and dirt/sand/gravel.

Figure 3-2 Weight-Based Composition of C&D Waste Based on C&D Material Groups

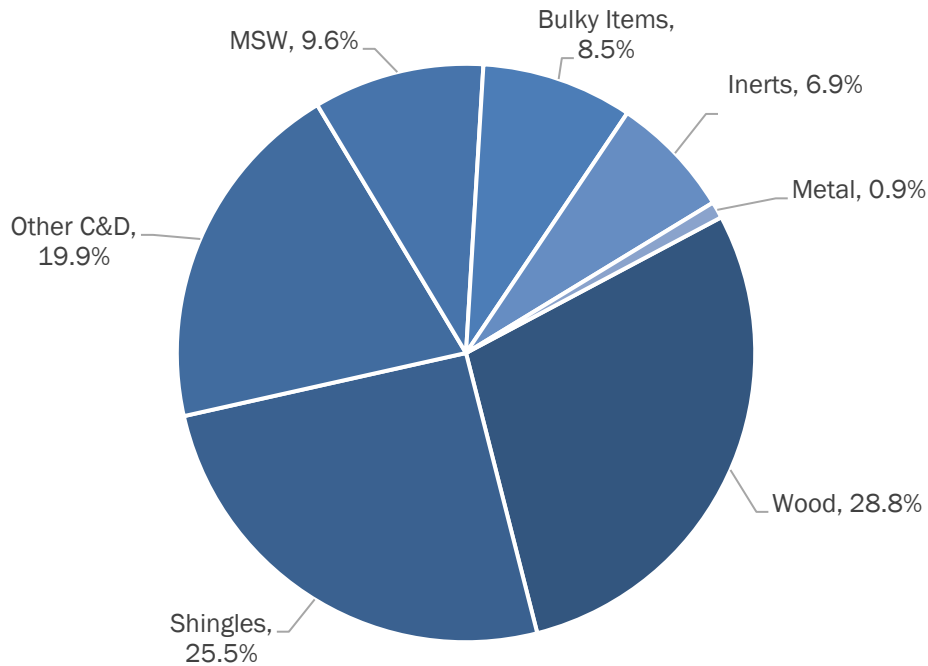

Figure 3-3 identifies the proportion of C&D that could potentially be diverted from disposal. As shown, almost 60 percent of C&D debris is potentially divertible, although almost none of this material consists of mandated recyclables or mandated organics. Similar to the MSW section, the reader is cautioned in assuming everything identified as potentially divertible was in a condition to be diverted by the time it was discarded. OCC may be used for foot paths on construction sites and be muddied, for instance, but would have been counted as OCC when observed in a load.

3. CONSTRUCTION & DEMOLITION WASTE COMPOSITION

Figure 3-3 Recoverability of C&D Wastes

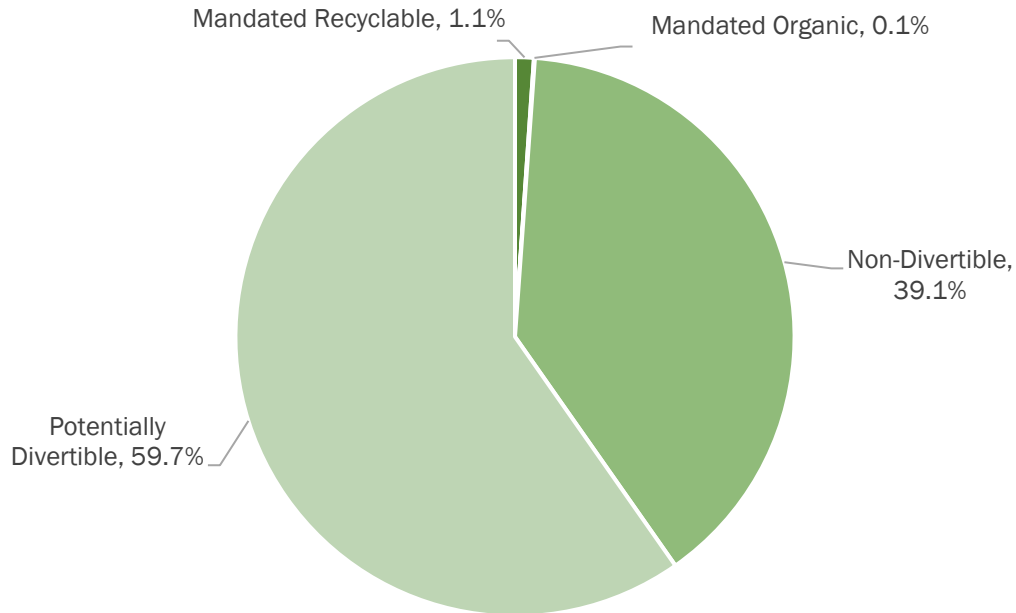

Table 3-1 presents a detailed statistical summary of the composition of C&D wastes and includes color coding to identify the recoverability of each category (as shown in Figure 3-3). The estimated composition percentages were applied to the total estimated 107,481 tons of C&D found to be generated in Vermont. Consistent with the MSW composition results, C&D results are calculated at a 90 percent level of confidence.

3. CONSTRUCTION & DEMOLITION WASTE COMPOSITION

Table 3-1 C&D Visuals Detailed Composition

Material Category	Est.				Est.		
	Percent	MOE	Tons		Percent	MOE	Tons
Paper	1.4%	0.8%	1,472	Glass	0.5%	0.2%	543
1 OCC (Old Corrugated Cardboard) & Kraft	1.1%	0.8%	1,151	23 Glass	0.5%	0.2%	543
2 Remainder & Composite Other Paper	0.3%	0.2%	321	Organics	0.3%	0.2%	270
Plastic	1.7%	0.7%	1,842	24 Yard Waste	0.0%	0.0%	49
3 #1 PET Bottles	0.0%	0.0%	11	25 Food Waste	0.0%	0.0%	11
4 Clean Recoverable Film	0.1%	0.2%	156	26 Remainder & Composite Other Organics	0.2%	0.2%	210
5 HDPE Buckets	0.1%	0.1%	91	C&D	83.4%	4.4%	89,592
6 Remainder & Composite Other Plastic	1.5%	0.5%	1,584	27 Asphalt Paving	0.0%	0.0%	0
Metal	0.9%	0.5%	996	28 Asphalt Shingles	25.5%	9.7%	27,365
7 Aluminum Beverage Cans	0.0%	0.0%	0	29 Carpet/Padding	2.6%	1.4%	2,744
8 HVAC Ducting	0.0%	0.0%	0	30 Ceiling Tiles	0.0%	0.0%	33
9 Non-Ferrous	0.2%	0.1%	229	31 Clean Dimensional Lumber	4.5%	2.0%	4,791
10 Other Ferrous	0.7%	0.5%	766	32 Clean Gypsum Board	6.1%	3.4%	6,511
Special Waste	6.5%	2.5%	6,940	33 Clean OSB	0.4%	0.3%	430
11 Appliances/White Goods	0.2%	0.2%	193	34 Concrete/Brick/Rock	5.0%	5.1%	5,391
12 Batteries - Lead Acid	0.0%	0.0%	0	35 Dirt/Sand/Gravel	1.9%	1.7%	1,998
13 Bulky Items	6.0%	2.4%	6,404	36 Insulation	1.0%	0.6%	1,085
14 Products with Embedded Batteries	0.0%	0.0%	0	37 Other Clean Engineered Wood	2.0%	1.1%	2,143
15 Electronics	0.3%	0.3%	312	38 Painted/Stained Wood	12.0%	3.5%	12,902
16 Items with CRTs	0.0%	0.0%	0	39 Treated Wood	3.9%	2.1%	4,214
17 Tires	0.0%	0.0%	23	40 Pallets/Crates	2.6%	1.3%	2,746
18 Mercury Containing Products	0.0%	0.0%	1	41 Plywood	3.9%	1.6%	4,172
19 Other HHW	0.0%	0.0%	4	42 Wood Furniture	2.3%	1.2%	2,470
20 Paint	0.0%	0.0%	2	43 Remainder & Composite Other C&D	9.9%	2.8%	10,595
21 Vehicle and Equipment Fluids	0.0%	0.0%	0				
MSW	5.4%	2.3%	5,828	Total	100.0%		107,481
22 Mixed MSW	5.4%	2.3%	5,828	Samples	99		
Mandated Recyclable	1.8%		1,928	Non-Divertible	38.6%		41,517
Mandated Organic	0.1%		60	Potentially Divertible	59.5%		63,976

Table 3-2 shows C&D composition recast into C&D-specific material groups, consistent with Figure 3-2. This table is provided so that readers have the underlying details of all results presented in this section.

3. CONSTRUCTION & DEMOLITION WASTE COMPOSITION

Table 3-2 C&D Visuals Detailed Composition (Based on C&D Material Groups)

Material Category	Est.		Material Category	Est.	
	Percent	Tons		Percent	Tons
MSW	9.6%	10,274	Wood	28.8%	30,968
1 OCC (Old Corrugated Cardboard) & Kraft	1.1%	1,151	24 Clean Dimensional Lumber	4.5%	4,791
2 Remainder & Composite Other Paper	0.3%	321	25 Other Clean Engineered Wood	2.0%	2,143
3 #1 PET Bottles	0.0%	11	26 Painted/Stained Wood	12.0%	12,902
4 Clean Recoverable Film	0.1%	156	27 Treated Wood	3.9%	4,214
5 HDPE Buckets	0.1%	91	28 Pallets/Crates	2.6%	2,746
6 Remainder & Composite Other Plastic	1.5%	1,584	29 Plywood	3.9%	4,172
7 Glass	0.5%	543	Bulky	8.5%	9,090
8 Yard Waste	0.0%	49	30 Appliances/White Goods	0.2%	193
9 Food Waste	0.0%	11	31 Bulky Items	6.0%	6,404
10 Remainder & Composite Other Organics	0.2%	210	32 Tires	0.0%	23
11 Batteries - Lead Acid	0.0%	0	33 Wood Furniture	2.3%	2,470
12 Products with Embedded Batteries	0.0%	0	Shingles	25.5%	27,365
13 Electronics	0.3%	312	34 Asphalt Shingles	25.5%	27,365
14 Items with CRTs	0.0%	0	Inerts	6.9%	7,390
15 Mercury Containing Products	0.0%	1	35 Concrete/Brick/Rock	5.0%	5,391
16 Other HHW	0.0%	4	36 Dirt/Sand/Gravel	1.9%	1,998
17 Paint	0.0%	2	Other C&D	19.9%	21,398
18 Vehicle and Equipment Fluids	0.0%	0	37 Asphalt Paving	0.0%	0
19 Mixed MSW	5.4%	5,828	38 Carpet/Padding	2.6%	2,744
Metal	0.9%	996	39 Ceiling Tiles	0.0%	33
20 Aluminum Beverage Cans	0.0%	0	40 Clean Gypsum Board	6.1%	6,511
21 HVAC Ducting	0.0%	0	41 Clean OSB	0.4%	430
22 Non-Ferrous	0.2%	229	42 Insulation	1.0%	1,085
23 Other Ferrous	0.7%	766	43 Remainder & Composite Other C&D	9.9%	10,595
			Total	100.0%	107,481
			Samples		99
Mandated Recyclable	1.1%	1,162	Non-Divertible	38.6%	41,517
Mandated Organic	0.1%	60	Potentially Divertible	60.2%	64,742

Finally, Table 3-3 shows the number of samples in which individual beverage containers were identified and includes a count of visible containers. Although the weight of beverage containers in the C&D loads was insignificant compared to the larger categories of C&D wastes, one-third of C&D samples were observed to include some beverage containers – primarily PET bottles and aluminum cans – which are mandated recyclables and not legally disposable in the C&D waste stream.

Table 3-3 Containers Found In C&D Samples

Container Type	Number of Samples		Total Item Counts	
	Count	Percentage of Samples	Count	Percentage of Total Items
#1 PET Bottles	28	28.3%	347	64.9%
#2 HDPE Bottles	4	4.0%	4	0.7%
Aluminum Cans	24	24.2%	172	32.1%
Glass Bottles	3	3.0%	12	2.2%
Total	34	34.3%	535	100.0%

3. CONSTRUCTION & DEMOLITION WASTE COMPOSITION

3.2 COMPARISONS WITH 2018 STUDY

This section provides multiple comparisons of the 2023 Study and the 2018 Study of C&D waste composition. Figure 3-4 compares the composition by conventional material groups. As shown, the composition remained quite consistent, although slight differences were observed in certain groups. In particular, the 2023 Study observed less Metal and Paper, and a higher percentage of municipal solid waste (MSW). Confidence intervals are shown to better inform the comparisons; where confidence intervals overlap, there is likely little to no actual difference between the two groups.

Figure 3-4 Comparison of Visually Surveyed C&D Composition, 2023 vs. 2018

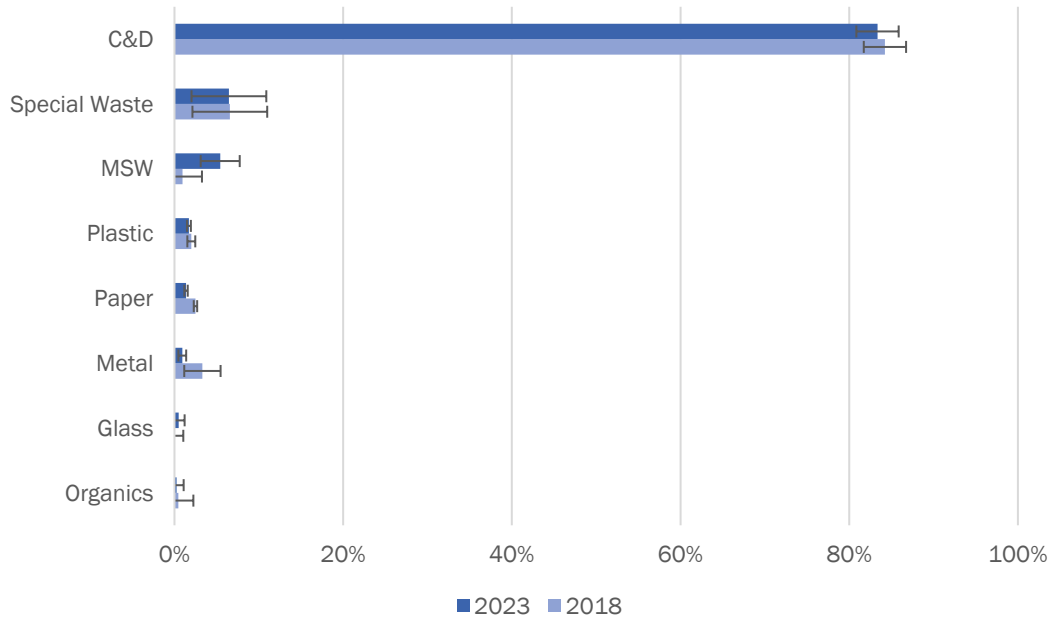
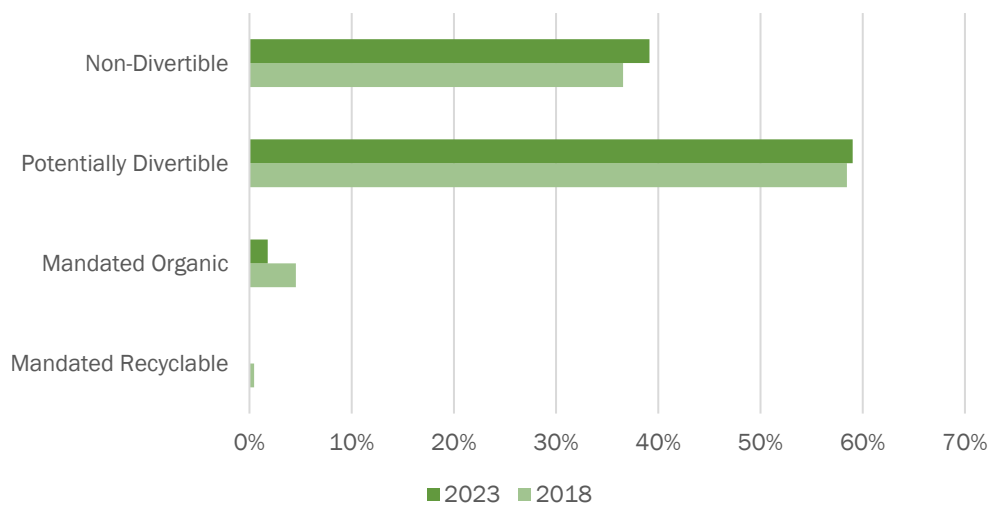

Figure 3-5 compares the recoverability of the C&D debris from the 2023 Study with the 2018 Study. This figure suggests that the incidence of both potentially divertible and non-divertible materials has increased, while mandated organic material decreased.

Figure 3-5 Comparison of C&D Waste Recoverability, 2023 vs. 2018



3. CONSTRUCTION & DEMOLITION WASTE COMPOSITION

Figure 3-6 compares the top ten most prevalent materials found in the 2023 Study with the 2018 Study results. Note that the 2023 Study expanded the number of categories of wood found in C&D debris. For comparison, the 2023 Study results have been recombined as closely as possible for purposes of this comparison of the top 10 most prevalent materials. However, it is possible that differences in the underlying wood category definitions contribute to the differences between the studies.

Figure 3-6 Top 10 Most Prevalent C&D Wastes, 2023 vs. 2018

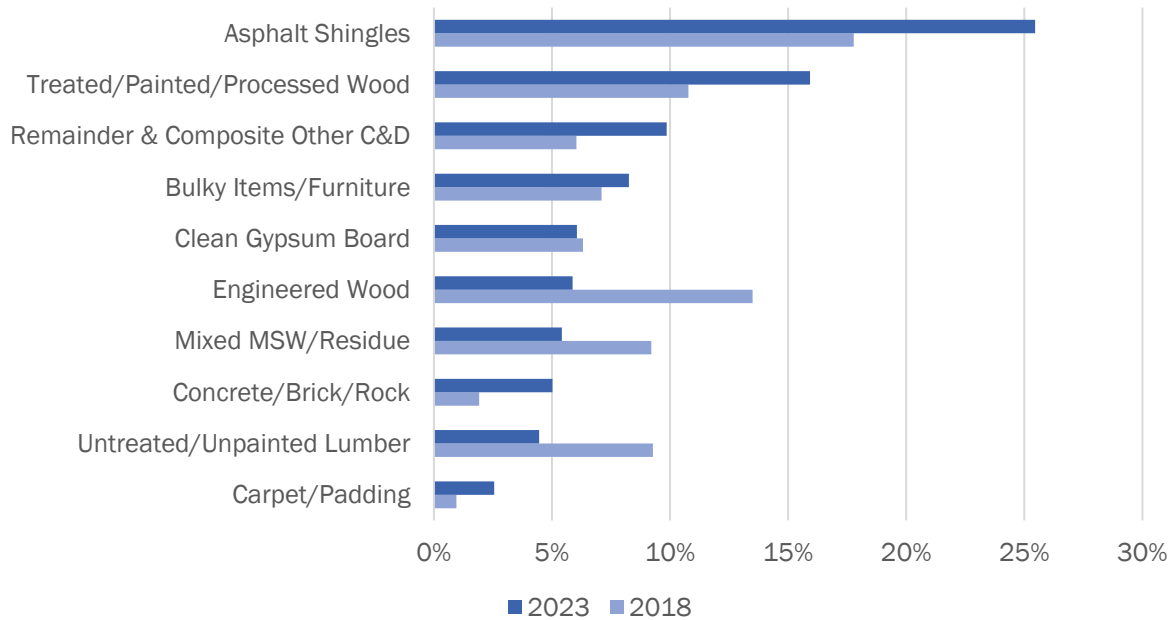

Additional analysis may reveal further findings of note for the C&D composition data set developed from this research. Developers, builders, haulers, C&D processors, demolition and deconstruction organizations, and reuse industry stakeholders may further parse this data in efforts to improve their businesses and increase diversion from the sector.

3. CONSTRUCTION & DEMOLITION WASTE COMPOSITION

This page is intentionally left blank.

4. ANALYSIS OF VERMONT WASTE COMPOSITION

4.1 VERMONT AGGREGATE WASTE COMPOSITION

Although both MSW and C&D debris composition has been calculated separately in both this and the prior study, this 2023 update takes a final step to combine these streams to calculate a combined Vermont solid waste composition. Combining the MSW and C&D waste streams requires that the material categories and groups be mapped, and then combines the composition of each stream in proportion to the tonnage contribution of each.¹

Figure 4-1 presents the composition of disposed solid waste in Vermont. As shown, the aggregate waste stream contains numerous varieties of material, with the largest group – C&D debris – at almost 24 percent. While most of the material groups are self-explanatory, the Special/Other category includes several significant materials including furniture/bulky items (5.7 percent), textiles/leather (5.1 percent), diapers/sanitary products (3.2 percent), fines/mixed residue (2.6 percent), rubber (0.4 percent) and tires (0.2 percent).

Figure 4-1 Vermont Statewide Disposed Waste (MSW + C&D) Composition by Material Group

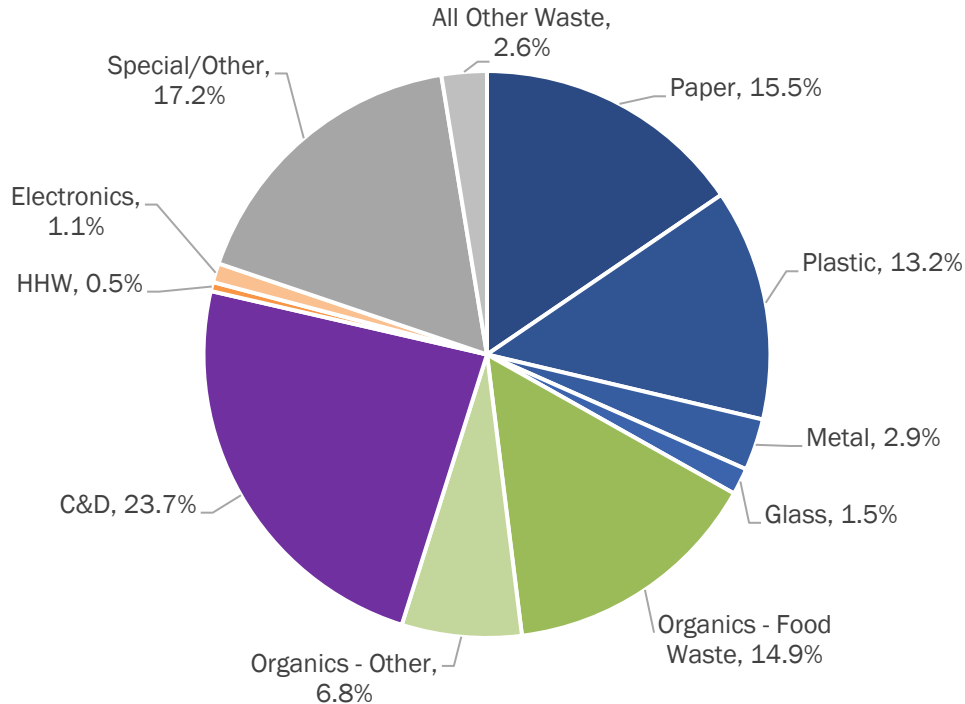

Figure 4-2 presents the divertibility of disposed solid waste in Vermont. Less than 10 percent of all disposed waste consists of mandated recyclables (cardboard, mixed paper, metal cans, plastics, and glass bottles, etc.), with another 17 percent being mandated organics (food waste, leaf and yard debris, etc.). Potentially divertible materials, such as textiles, certain plastics like 5-gallon buckets or retail film bags, clean drywall, electronics, scrap metal, and asphalt shingles, sums to just under 30 percent. Some portion

¹ Materials from the MSW hand sorts that were mapped into C&D include: asphalt/brick/concrete, asphalt shingles, C&D metal, drywall/gypsum board, oriented strand board, other residual C&D, painted & treated wood, plywood, and carpet & carpet padding.

4. ANALYSIS OF VERMONT WASTE COMPOSITION

of this material may be divertible if the material can be economically separated, and markets become available for this material. However, the largest component of solid waste, at 44 percent, is not currently divertible on a widespread basis.

Figure 4-2 Vermont Disposed Waste Composition by Divertibility

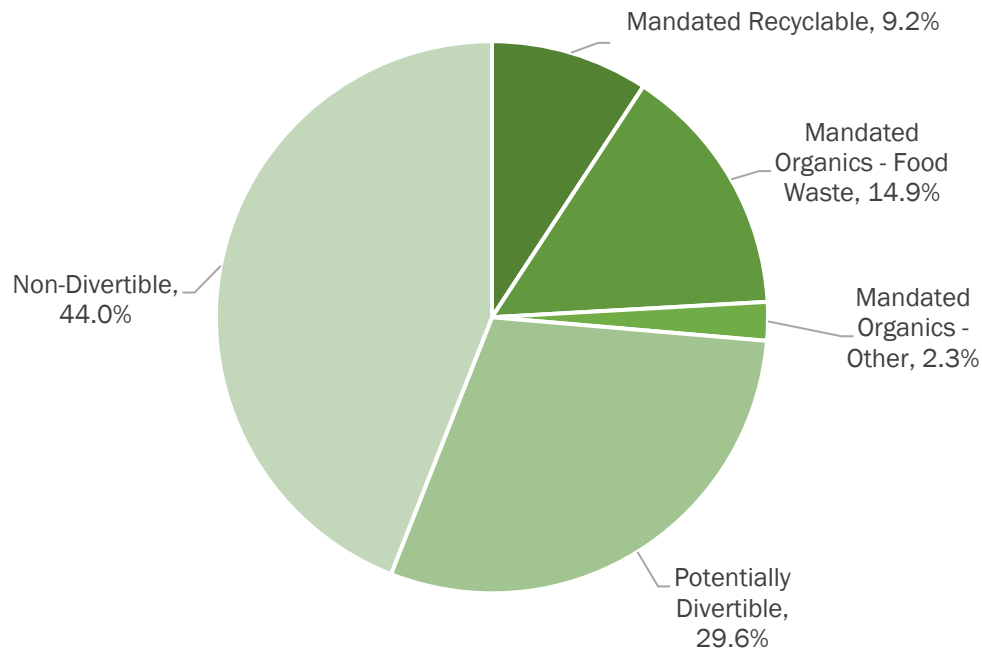

A close review of the data suggests that there are opportunities for increasing diversion in some of the potentially divertible and non-divertible materials, which measure 74 percent of the waste stream. For example, the textile industry has recently ramped up efforts to increase circularity of their products, and innovative textile recovery programs (including curbside collection) have begun to emerge in some parts of the country. Similarly, there are increasing efforts to develop recovery technologies for traditionally hard-to-recycle plastics. While most of these processes are seeking to recover the plastic for some form of energy recovery rather than recycling, this would reduce the loss of such items to landfill. Perhaps more furniture and bulky items (at 5.6 percent) could be reused if better repair options existed.

However, it is equally important to note that while nearly 30 percent of the waste stream is *potentially divertible*, history tells us that actually diverting a significant portion of this material would be very difficult and costly. For example, asphalt shingles make up six percentage points and there have been numerous attempts over the years throughout New England, including in Vermont, to divert this material – primarily to road construction. Currently, Vermont use of recycled asphalt shingles in hot mix asphalt is not viable on a large scale due to concerns over cracking performance, particularly in Vermont’s cold climate. Additionally, asphalt shingles have been found to contain PFAS, which is also a concern. Another 1.6 percentage points are represented by drywall, which, like asphalt shingles, has been attempted to be recycled, but is hindered due to coatings and paint contamination, the friable nature of the material, low value/limited markets for this recycled material, and the relatively inexpensive access to low-cost air emission control inputs into virgin drywall, all of which combines to make virgin drywall much less costly. Further, oriented strand board and plywood both contain glues which significantly reduce potential uses of these materials. And finally, compostable paper has, in most cases, been prohibited from food waste

4. ANALYSIS OF VERMONT WASTE COMPOSITION

composting systems due to worries about contamination and does not add energy value to anaerobic digestion facilities.

In conclusion, continued emphasis on recovering more recyclables, further diverting food waste, and investigating options to divert textiles and rigid plastics is likely to have the greatest impact on landfill tonnage disposal.

Table 4-1 shows a detailed summary of the composition of solid waste in Vermont. Note that this table does not include an estimate of the margin of error, because the calculation was not performed with the propagation of the statistical analysis. Rather, this table features the weighted composition based on the tonnage of MSW and C&D.

4. ANALYSIS OF VERMONT WASTE COMPOSITION

Table 4-1 Vermont Statewide Aggregate Waste Composition (MSW & C&D)

Material Category	Est.			Est.	
	Percent	Tons		Percent	Tons
Paper	15.5%	75,153	Electronics	1.1%	5,297
1 OCC & Kraft Paper	2.9%	14,005	39 Banned - Non-CED Electronics	0.1%	584
2 Boxboard (Chipboard)	0.9%	4,377	40 CEDs - CRTs	0.0%	0
3 Newsprint	0.2%	1,201	41 CEDs - Computer Peripherals	0.0%	27
4 Mixed Recyclable Paper	1.8%	8,890	42 CEDs - Desktop Computers	0.0%	0
5 Magazines/Catalogs	0.2%	739	43 CEDs - Laptops/Tablets	0.0%	81
6 High Grade Office Paper	0.1%	599	44 CEDs - Printers	0.1%	312
7 Polycoated/Aseptic Containers	0.2%	1,098	45 CEDs - Television/Monitors (Non-CRT)	0.0%	106
8 Books	0.3%	1,547	46 Products with Embedded Batteries	0.0%	102
9 Compostable Paper	5.7%	27,807	47 Small Appliances	0.6%	2,971
10 Remainder/Composite Paper	3.1%	14,891	48 White Goods	0.2%	1,114
Plastic	13.2%	64,126	Household Hazardous Waste	0.5%	2,514
11 #1 PET Bottles	0.7%	3,622	49 Batteries - Lead Acid	0.0%	0
12 #2 HDPE Bottles	0.4%	2,172	50 Batteries - Primary	0.1%	255
13 #3 - #7 Bottles	0.1%	334	51 Batteries (Rechargeable)	0.0%	2
14 #5 PP Food Containers	0.7%	3,178	52 Mercury Cont. Products - Lamps	0.0%	8
15 #6 PS Rigid Food/Beverage Containers	0.0%	222	53 Mercury Cont. Products - Thermostats	0.0%	0
16 #6 EPS Food/Beverage Containers	0.2%	852	54 Mercury Cont. Products- Other	0.0%	3
17 Bulky Rigid Plastics > 1 Gallon	1.3%	6,214	55 Paint	0.1%	656
18 Plastic Thermoforms	0.7%	3,290	56 Other HHW	0.3%	1,591
19 Film - Agriculture/Marine Shrink Wrap	0.3%	1,312	Construction & Demolition	23.7%	115,232
20 Film - Retail Bags	0.1%	305	57 Asphalt, Brick and Concrete (ABC)	1.1%	5,508
21 Film - Garbage Bags	2.1%	10,030	58 Asphalt Shingles	6.0%	29,023
22 Film - Other Bags	0.7%	3,631	59 C&D Metal	0.1%	290
23 Film - Other - Non-Bag	3.0%	14,460	60 Drywall/Gypsum Board	1.6%	7,647
24 Remainder/Composite Plastic	3.0%	14,504	61 Oriented Strand Board	0.1%	710
Metal	2.9%	14,323	62 Other/Residual C&D	4.8%	23,510
25 Aluminum Cans	0.3%	1,569	63 Wood - Painted and Treated	4.8%	23,380
26 Aluminum Foil, Pans, and Containers	0.4%	1,736	64 Plywood	2.9%	14,039
27 Ferrous Containers	0.4%	1,798	65 Carpet & Carpet Padding	2.3%	11,122
28 Other Ferrous	1.3%	6,317	Special/Other	17.2%	83,577
29 Other Non-Ferrous	0.6%	2,902	66 Diapers/Sanitary Products	3.2%	15,467
Glass	1.5%	7,381	67 Fines/Dirt/Mixed Residue	2.6%	12,677
30 Glass Bottles & Jars	0.9%	4,140	68 Furniture/Bulky Items	5.6%	27,426
31 Other Glass	0.7%	3,241	69 Rubber	0.4%	2,004
Organics	21.7%	105,384	70 Textiles and Leather	5.1%	24,790
32 Food Waste - Contained in Packaging	6.2%	30,112	71 Tires	0.2%	1,212
33 Food Waste - Unpackaged	8.7%	42,102	All Other Waste	2.6%	12,537
34 Branches & Stumps >1"	0.0%	116	72 All Other Waste Not Elsewhere Classifi	2.6%	12,537
35 Leaves, Grass, & Brush <1"	0.9%	4,491			
36 Wood - Clean	1.3%	6,331			
37 Pet Waste	3.2%	15,460	Total	100.0%	485,523
38 Other Organics	1.4%	6,773	Samples	289	
Mandated Recyclable	9.2%		Non-Divertible	44.0%	
Mandated Organic	17.1%		Potentially Divertible	29.6%	

4. ANALYSIS OF VERMONT WASTE COMPOSITION

4.2 RECOVERY RATES

A second application for the results of the waste composition and supplemental research performed for this project is that it is possible to estimate recovery rates, sometimes called capture rates, for mandated recyclables and food scraps, which are both disposal-banned and required by state law to be separated from trash. These estimates are shown in the following subsections.

When reviewing this section, and when making comparisons with the 2018 Study, it is important to note that the “recycling” portion of both recovery rate calculations include estimates in addition to reported data; and that the sources for such estimates differed in each study. In 2018, the Bottle Bill estimate was from a 2013 Systems Analysis (17,480 tons), whereas in 2023, the Bottle Bill tonnage is a 5-year average of redeemed containers collected by TOMRA (10,066 tons). For both recovery rates, the economic recycling estimates are from the “direct to broker” surveys conducted by the project team. However, the result of the two surveys were quite different (2,686 tons containers and 20,707 tons fibers in 2018 vs. 13 tons containers and 9,447 tons fibers in 2023), which may be due to both actual changes in recycling tonnage and changes in survey methodology and response rates.

4.2.1 RECYCLING RECOVERY RATE

Table 4-2 compiles the data needed to estimate the State’s recovery rate for mandated recyclables, defined in state law as aluminum and steel cans, aluminum foil and aluminum pie plates, glass bottles and jars from foods and beverages, polyethylene terephthalate (PET) plastic bottles or jugs, high density polyethylene (HDPE) plastic bottles and jugs, corrugated cardboard, white and colored paper, newspaper, magazines, catalogues, paper mail and envelopes, boxboard, and paper bags. Refuse tons are estimated by applying the waste composition average percentages to the total disposed tons of MSW. Recycling tons are a combination of those reported to DEC, plus the reported direct-to-broker recycling of cardboard, other paper, and metal/glass/plastic containers uncovered in this research, albeit in summary categories that roll-up different individual recyclables, not all of which are mandated recyclables. (For example, due to the way recycled plastic containers are reported to DEC, the Containers-Reported category includes some #5 plastic in addition to #1 and #2. While not a mandated recyclable, #5 plastic is widely accepted for recycling in Vermont, including at both MRFs.) No attempt has been made to map the refuse and recycling data; rather, the recovery rate is calculated for the sum of all mandated “blue bin” recyclables disposed in refuse, recyclables reported to the state by certified facilities, and materials identified through the Direct-to-Broker research (see report section 7). As shown, over 72 percent of targeted recycling materials are estimated to be captured in the State’s recycling programs. In the opinion of the Project Team, this is well above average for these materials.

4. ANALYSIS OF VERMONT WASTE COMPOSITION

Table 4-2 Vermont Statewide Recycling Recovery Rate

Material	Refuse	Recycling ¹	Total
OCC & Kraft Paper	12,658.4		12,658.4
Boxboard (Chipboard)	4,310.8		4,310.8
Newsprint	1,182.5		1,182.5
Mixed Recyclable Paper	8,755.1		8,755.1
Magazines/Catalogs	727.9		727.9
High Grade Office Paper	589.7		589.7
#1 PET Bottles - BB	401.6		401.6
#1 PET Bottles - EBB	2,228.9		2,228.9
#1 PET Food and Dairy Bottles and Jars - NBB	925.4		925.4
#2 HDPE Bottles - BB	9.2		9.2
#2 HDPE Bottles - EBB	542.4		542.4
#2 HDPE Food & Dairy Bottles and Jars - NBB	1,587.0		1,587.0
Aluminum Beverage Cans - BB	1,290.8		1,290.8
Aluminum Beverage Cans - EBB	254.2		254.2
Aluminum Foil, Pans, and Containers NBB	1,709.5		1,709.5
Ferrous Containers	1,770.8		1,770.8
Glass Beverage Bottles - BB	1,345.4		1,345.4
Glass Beverage Bottles - EBB	1,587.8		1,587.8
Glass Beverage Bottles - NBB	843.6		843.6
Fibers - Reported		68,757.0	68,757.0
Containers - Reported		16,352.0	16,352.0
Single Stream - Reported		605.0	605.0
Bottle Bill Returns		10,066.0	10,066.0
Containers - Economic Recycling Estimate ²		126.9	126.9
Fibers - Economic Recycling Estimate ³		14,608.2	14,608.2
Total	42,721.2	110,515.1	153,236.3
<i>Recovery Rate</i>			<i>72.1%</i>

⁽¹⁾ As reported by DEC for 2022.

⁽²⁾ Value includes the sum of cardboard and other paper from tables 8-4 and 8-7.

⁽³⁾ Value includes the sum of metal, glass, plastic from tables 8-4 and 8-7.

4.2.2 FOOD SCRAP RECOVERY RATE

Similarly, the data compiled in this study, as shown in Table 4-3, enables the estimate of a recovery rate for food scraps. There are multiple data sets that play into this calculation, including:

- MSW hand sorts, which estimate the food scraps still being disposed in landfill.
- Reported processing, which was provided by DEC and includes reported tonnage for AD and compost facilities, repackaging facilities, food rescue (through food banks), and an estimate of the food contained in food processing residuals.
- Unreported tons are those identified through the Organics Management Transportation research (see Section 6). As the universe of potential food scrap generation is immense, it cannot be confirmed that the generator questionnaire tons provided were representative of the universe as a whole. With 51 percent of permitted transporters responding, however, the 4,756 tons identified as delivered to out-of-state facilities, animal feeding operations, and farms is a stronger data set.

4. ANALYSIS OF VERMONT WASTE COMPOSITION

- Estimated residential food waste diversion, which was derived through the Residential Food Waste Management questionnaire (see Section 5). While some of this estimated diversion (“Collection by Hauler” and “Drop-off/Collection Site”) might go through a reporting compost facility or transfer station, and thus be double counted, it was included in this estimate since the amount passing through a reporting facility is unknown. Additionally, some diversion is likely missing from this food scrap recovery rate, such as some on-farm composting and animal feed, so it made sense to err on the side of including this diversion in the estimate.

While reported tonnages are firm, there is measurable statistical uncertainty associated with the (non-residential) food scrap generator estimate. Further, the residential food waste diversion tonnage is also an estimate, with no attempt at calculating the associated statistical uncertainty.

Table 4-3 Basis for Vermont Statewide Food Scrap Recovery Rate Estimates

	Source	Low	Avg	High
Reported	AD/Compost/Transfer Station	18,681	18,681	18,681
	Depackaging Facility	6,088	6,088	6,088
	Food Bank (rescue)	3,430	3,430	3,430
	Food Processing Residuals (Depack)	3,304	3,304	3,304
	Food Processing Residuals	2,556	5,112	7,669
Unreported	Transporters	4,756	4,756	4,756
	Generators	2,037	2,037	2,037
Estimated	Residential Compost ^[4]	38,987	38,987	38,987
Total Diverted		79,840	82,396	84,952
Disposed	Food Waste Contained in Packaging	26,643	29,650	32,658
	Food Waste Unpackaged	37,882	41,462	45,043
Total Disposed		64,525	71,113	77,701
Total Generated		144,365	153,509	162,653

^[4] This diversion estimate, derived in Section 6, contains multiple assumptions is subject to meaningful uncertainty as a result. However, it is not possible to statistically calculate the degree of uncertainty, and as a consequence no attempt has been made to estimate the low and high bounds.

The Project Team notes that DEC provided a figure of 51,125 tons of food processing residuals that are reported to DEC as being recovered mainly via anaerobic digestion with some composting. Food processing residuals can cover a broad array of food wastes from off-spec food manufacturing products that can be solids like powdered milk and coffee grounds to liquids like fats/oils, beverages, wash waters, and other liquid byproducts. To attempt to adjust the significant volumes of food processing residuals to establish an amount that was food waste (food or beverage) the Project Team used the following discounting system: low, average, and high estimates of 5 percent, 10 percent, and 15 percent, respectively, of the total (51,125 tons) as food processing residuals recovered in diversion activity.

For Disposed low and high estimates, the Project Team applied the margin of error to the average disposed food waste identified in the MSW hand sort results (see Section 2).

Table 4-4 shows the low, average, and high range for Vermont’s estimated food scrap recovery rate. The low estimate is calculated adding the high value for disposed food waste and low number for the total diverted, then dividing the low total diverted into that sum. The high estimate is the reverse (add low value for disposed food waste and high total diverted, then divide the high total diverted into that sum.) As shown, food scraps appear to be diverted at a 51-57 percent rate. The Project Team is not aware of other states that have attempted to estimate their food scrap recovery rate, but this estimate would appear to be

4. ANALYSIS OF VERMONT WASTE COMPOSITION

at the high end of the range of food recovery as observed by the Project Team under limited availability of data.

Table 4-4 Vermont Statewide Food Scrap Recovery Rate Estimates

Estimate Level	Rate
Low	50.7%
Average	53.7%
High	56.8%

5. MRF RESIDUE COMPOSITION

5.1 RESIDUE STREAMS

While all MRFs generate residue, in practice every MRF has a unique processing configuration that ejects residue materials in at least one, but often more, points along the processing line. To meet the objective of characterizing MRF residue, it is first necessary to identify the various sources of residue within a MRF, and to estimate the contribution of each residue source towards the entirety of the residue generated at the MRF.

Two MRFs hosted field data collection to enable sampling and sorting of their residues: Rutland and Chittenden. Both MRFs underwent a processing line walk-through prior to sampling and sorting, so that the Project Team could identify the residue generation points within the MRF. The findings on MRF residues presented in this section combine the data from both MRFs weighted by their contribution to total Vermont residue (as reported to DEC), to represent a composite of MRF residue data from single-stream processing in Vermont.

Pictures of material sampled from various ejection points and categorical examples are included in the Photo Journal at the end of this report section to better illustrate the nature of materials contained in the residue.

Table 5-1 shows that seven discrete sources of residue – often called ejection points – were identified within the two MRFs. This table also shows the number of samples of material that were obtained and sorted from each residue source. As shown, the split between facilities was nearly even for every ejection point and the team was able to take and sort more samples than planned. The resulting composition of each ejection point serves as one building block in developing a representative profile of MRF residue.

Table 5-1 Sample Acquisition from Discrete Residue Sources at Host MRFs

Ejection Point for Residue	MRF 1	MRF 2	Total
1. Tip Floor Pre-Sort Contaminants	2	5	7
2. Process Line Pre-Sort Contaminants	12	12	24
3. Fiber Line Residue	8	8	16
4. Post Fiber/Pre-Container	N/A	5	5
5. Container Line Residue	9	7	16
6. Glass Residue	8	6	14
7. End of Line Residue	7 ^[1]	8	15
Total	46	51	97
<i>Total Planned</i>	<i>29-46</i>	<i>29-46</i>	<i>58-92</i>

^[1] End of Line residues were later determined to aggregate other ejection points at this facility and were therefore duplicative. These samples were consequently not included in the overall calculation of residue composition.

Table 5-2 shows the 2023 tonnage received as well as residue reported to DEC by the two MRFs in the study. As shown, the Rutland MRF receives materials generated in other states. For purposes of calculating a Vermont average residue composition, the individual composition for each MRF was combined based on the proportion of residue tons attributable to Vermont sources. As shown, for this report it is calculated that 6,659 tons of residue were attributable to Vermont single-stream recyclables. It should be noted here that the residue rates reported from the two Vermont MRFs in Table 5-2 are at the low end of the range of residues for single-stream recyclables processing as reported in national literature.

5. MRF RESIDUE COMPOSITION

Table 5-2 Recycling & Residue Tons at Host MRFs (2023)

MRF	Inbound MRF Recyclables					Total Residue Tons	Residue Tons Attributable to Vermont Loads
	Vermont Load Tons	Out-of-State Load Tons	Total Tons Received	Vermont Contribution Percentage	Residue Percentage		
Rutland	25,739	6,250	31,989	80.5%	12.6%	4,038	3,249
Chittenden	43,355	0	43,355	100.0%	7.9%	3,410	3,410
Total	69,095	6,250	75,345			7,448	6,659

The second building block that is needed to estimate the composition of MRF residue is the relative contribution that each residue ejection point makes to the whole. MRFs routinely combine all residue material when recording the overall quantity of non-recovered materials, and do not customarily calculate the fraction from each individual ejection point. As part of the study, however, both MRFs conducted weigh outs of the residue ejection points over several days to inform the weighting of the ejection point results.

Figure 5-1 shows the contribution of residue from each ejection point to the total MRF residue. As shown, the largest contributors to the overall MRF residue composition were pre-sort contaminants, at 42 percent. These are typically large items that are not accepted at the MRF and may include a wide range of bulkier materials (e.g., kitchen sinks, automotive parts, dimensional lumber) as well as materials that impair the mechanical and optical sorting equipment (such as garden hoses, Christmas lights, plastic tarps, and bags of solid waste). Including tip floor pre-sort contaminants, which add another 10 percent, over half of the residues generated at these MRFs was removed prior to entry into the processing system.

Figure 5-1 Generic Weighting of MRF Residue Streams

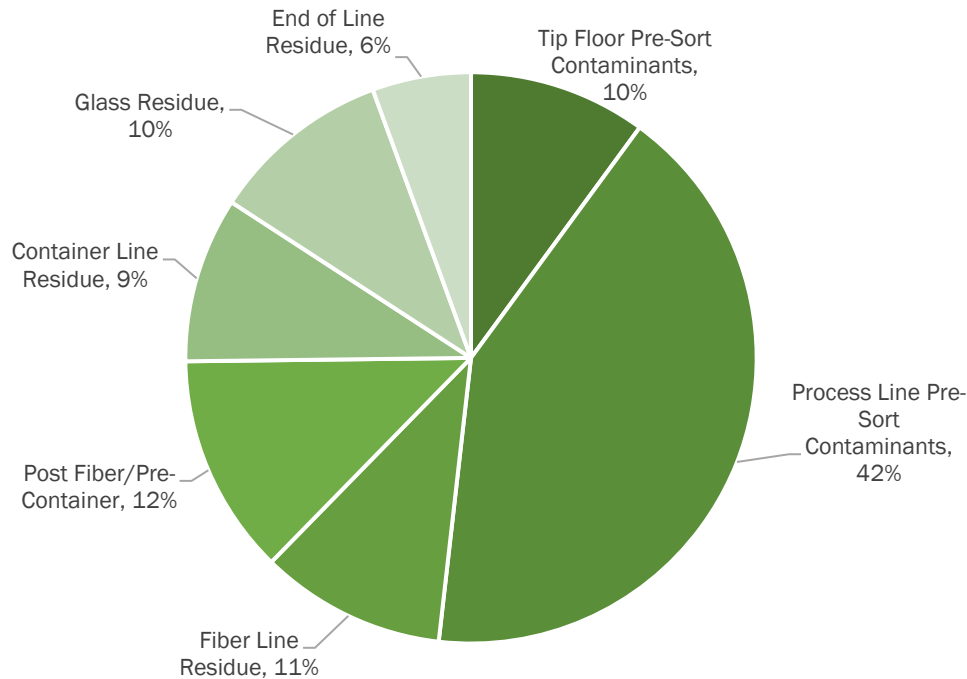

5. MRF RESIDUE COMPOSITION

The percentages in Figure 5-1 have been used as the basis for weight-based aggregation of the MRF residue.

Figure 5-2 presents the estimated composition of MRF residue by material group. This graphic is primarily included to conform with the presentation of MSW and C&D wastes in the preceding sections so that readers can compare these streams. Results are presented in weight-percent, although the same graphics can be readily converted to present results measured by tonnage. It is noteworthy that Plastics and Other Wastes comprise the largest fraction of residue, while Paper, Metal, and Glass are relatively small. As noted previously with respect to divertibility, unclean and saturated materials, including those that might otherwise be recyclable, end up in residue. Setout and collection circumstances affect the condition of materials before they arrive at the MRF.

Figure 5-2 Estimated Composition of MRF Residue by Material Group

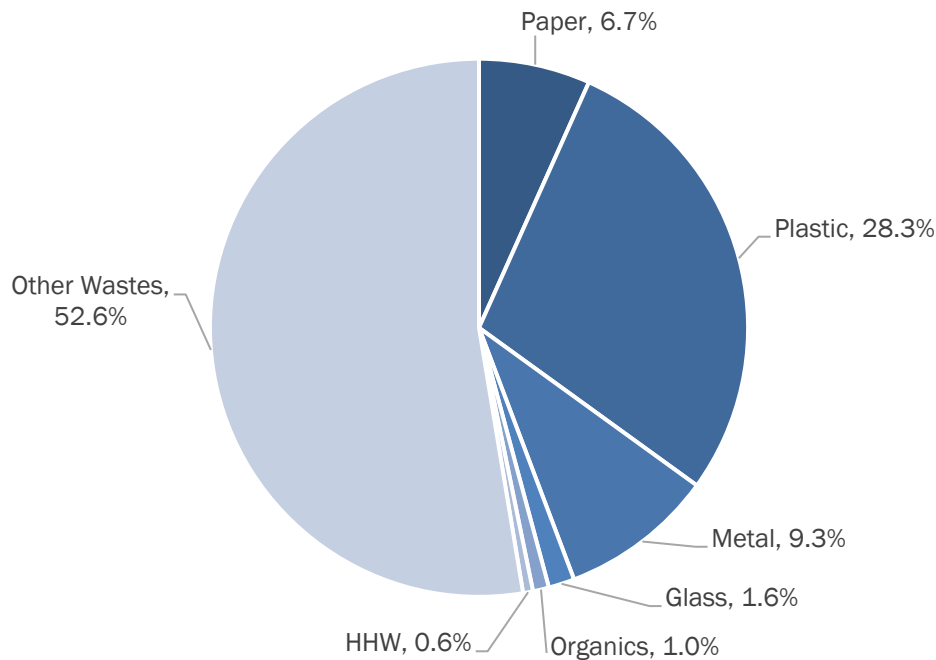

Perhaps of greater interest, Figure 5-3 displays the estimated composition of MRF residues by their divertibility at an MRF. For purposes of this section of the report, divertibility is considered from the perspective of a MRF operator.

5. MRF RESIDUE COMPOSITION

Figure 5-3 Estimated Composition of MRF Residue by Divertibility Class

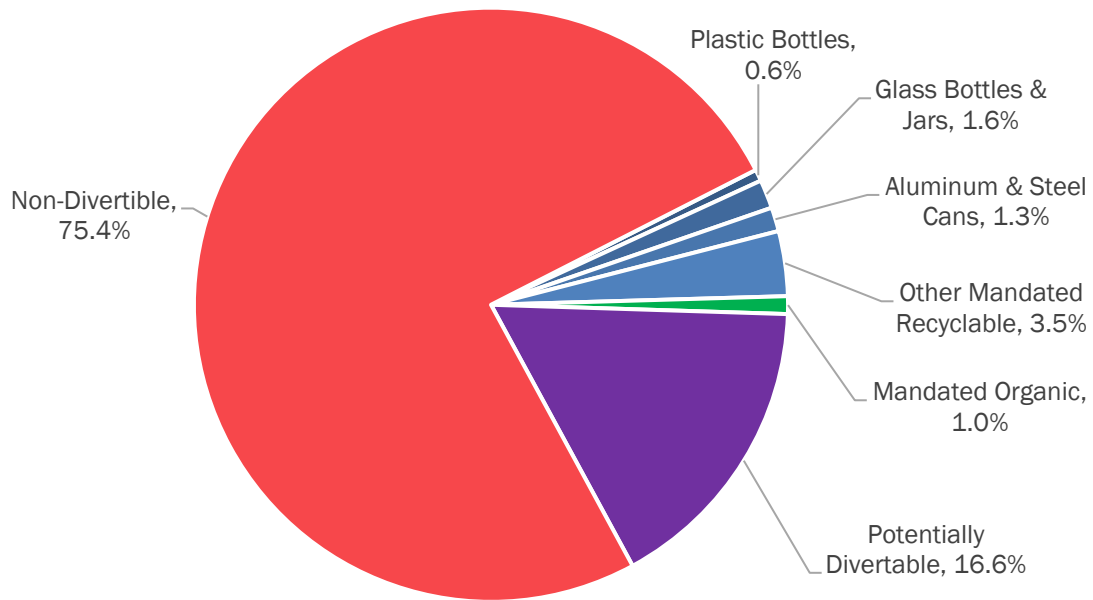

There are several important conclusions that can be drawn from this finding:

- **Plastic, Glass and Metal Bottles and Cans:** MRFs are first and foremost designed to capture a majority of #1 and #2 plastic bottles (Table 4-3 materials #7 and #9), glass bottles and jars (#18), and steel and aluminum cans (#19 and #21). As shown in this table, these targeted items make up a very small percentage of total residues, at a combined 3.5 percent of all residue.
- **Other Mandated Recyclables:** Other non-bottle, non-can mandated recyclables totaled only another 3.5 percent. This fraction was predominantly small cardboard and paper which had been size-reduced from processing, and in some cases could have been contaminated with liquids prior to or during collection or processing.
- **Mandated Organic:** A very small fraction of organic material was found in the MRF, which is positive. Organics, especially food, are highly contaminating to other recyclable materials.
- **Potentially Divertible:** This fraction is labeled in a manner consistent with the presentation of results for the MSW hand sorts. Many MRFs – including the two that hosted this study – have been able to marginally divert some of this material, such as bulky plastics, and scrap metal. However, almost the entirety of this pie piece is comprised of materials that are technically contaminants to single-stream recyclables. A notable exception is #5 PP plastic, which is accepted and baled by both MRFs.
- **Non-divertible:** The majority of residues were found to be non-divertible materials. In the context of a MRF, this pie piece is entirely comprised of contaminants to the recycling process that should never have been delivered to the MRF in the first place.

Table 5-3 provides the detailed composition of MRF residue. This table also applies the estimated composition to the amount of residue attributable to processed Vermont recyclables (see Table 4-2).

5. MRF RESIDUE COMPOSITION

Table 5-3 Estimated Composition of MRF Residue in the Aggregate

Material Category	In-State Residue		Material Category	In-State Residue	
	Mean	Tons		Mean	Tons
Paper	6.7%	446.2	Glass	1.6%	104.2
1 OCC	1.0%	63.5	19 Glass Bottles & Jars	1.6%	104.2
2 Boxboard (chipboard)	0.3%	22.5	Metal	9.3%	617.6
3 Mixed Recyclable Paper	1.8%	120.7	20 Aluminum Cans	0.3%	21.3
4 Polycoated/Aseptic Containers	0.4%	29.3	21 Aluminum Foil, Pans, and Containers	0.4%	28.6
5 Compostable Paper	0.8%	52.0	22 Ferrous Containers	1.0%	65.4
6 Remainder/Composite Paper	2.4%	158.4	23 Other Ferrous	5.3%	356.2
Plastic	28.3%	1,882.9	24 Other Non-Ferrous	2.2%	146.2
7 #1 PET Bottles & Jars	0.1%	7.0	Organics	1.0%	64.2
8 #1 PET Other Containers	1.1%	73.0	25 Food Waste	1.0%	64.2
9 #2 HDPE Bottles & Jars	0.5%	35.4	Household Hazardous Waste	0.6%	39.8
10 #2 HDPE Other Containers	1.0%	67.8	26 Batteries	0.0%	0.4
11 #3 PVC	0.1%	5.8	27 Other HHW	0.6%	39.5
12 #5 PP Bottles & Jars	0.2%	14.5	Other Waste	52.6%	3,504.3
13 #5 PP Other Containers	2.0%	130.9	28 All Other Wastes Not Elsewhere Categorized	30.6%	2,036.2
14 #6 PS Rigid Food/Beverage Containers	0.1%	7.8	29 2-Inch Minus Materials	11.8%	786.0
15 #6 Expanded Polystyrene (EPS)	0.0%	3.3	30 Bagged Materials	10.2%	682.1
16 Bulky Plastic	4.6%	307.9			
17 Film Plastic	14.5%	967.8			
18 Other Rigid Plastic	3.9%	261.7	Total	100.0%	6,659.3
Mandated Recyclable	7.0%	468.5	Non-Divertible at MRF	75.4%	5,022.2
at MRF	1.0%	64.2	Potentially Divertible at MRF	16.6%	1,104.3

These details offer further insight into the challenge of contamination entering the two MRFs:

- Predominantly Contaminants:** Overall, 76.5 to 93 percent of residues measured in this study were found to be contaminants to the recycling stream, range depending on the treatment of the various potentially divertible materials. Given that residue is, by definition, the material that is not recovered during processing, this finding is not surprising. This finding suggests at least 5,100 tons (Non-Divertible at MRF and Mandated Organic materials) entering these MRFs should not have been in the recyclables from the start and had to be removed by the facility in the effort to recover targeted recyclables.
- Bagged Materials:** Plastic bags are difficult to open and process in a MRF setting, so it is not surprising to see bagged materials in the residue stream. Bagged materials were treated as a category and not further sub-sorted to determine contents as was discussed and decided during initial field work planning with DEC and the MRFs.
- Small Particles:** Over 11 percent of residues were found to be smaller than 2-inches in size. As materials break and degrade during collection and sorting, this size reduction results in some loss of materials (shredded paper, broken glass, small format bottles) that are not practical to recover.
- Non-targeted Plastics:** There is a significant percentage of non-recoverable plastics in MRF residue. While these materials cannot easily be recycled, it is possible that other processors might be interested in recovering these plastics for energy recovery and other emerging recycling technologies.
- De Minimis Targeted Recyclables:** Targeted cardboard, boxboard, and paper (206.7 tons), plastic bottles and jars (42.4 tons), glass bottles and jars (104.2 tons), aluminum cans/foil/containers and steel cans (115.3 tons) made up only 7 percent (468.6 tons) of all residues.

5. MRF RESIDUE COMPOSITION

Table 5-4 calculates the increasingly smaller percentages of residue that was found to include mandated recyclables (0.7 percent) as well as the subset of bottles, jars, and cans (0.4 percent).

Table 5-4 Components of MRF Residue

Single Stream Fractions	Tons	Percent of Inbound
Inbound Loads Originating in Vermont	69,095	100.0%
Residue Attributable to Vermont Loads	6,659	9.6%
Mandated Recyclables Disposed as Residue ^[1]	469	0.7%
Bottles, Jars & Cans Disposed as Residue ^[2]	248	0.4%

^[1] Includes categories #1-3, 7, 9, and 19-22.

^[2] Includes categories #7, 9, 12, 19, 20, 22.

It is the opinion of the Project Team that the MRFs evaluated for this inaugural analysis of residue composition are doing what they were designed to do: namely, recover the cardboard, paper, plastic bottles, glass bottles, steel and aluminum cans that make up the traditional recycling stream. This is unsurprising given that the MRFs have an economic incentive to capture as close to 100 percent of these materials as possible.

5.2 COMPARISON OF RESIDUE COMPOSITION

This section presents the very different composition profiles of the individual residue ejection points in the host MRFs. Figure 5-4 compares the composition of MRF residue by material group. As shown, the composition of residue varies significantly depending on the ejection point as materials make their way through the sorting process. By weight, the largest MRF residues are “Other Waste” which varied greatly and included items such as textiles, wood, small furniture, rugs, rubber mats, crates, luggage, and composite items made of multiple materials. The other major residue categories are plastics—mostly film plastics, followed by some paper and some metal residues.

Figure 5-4 Comparison of MRF Residue Composition by Source

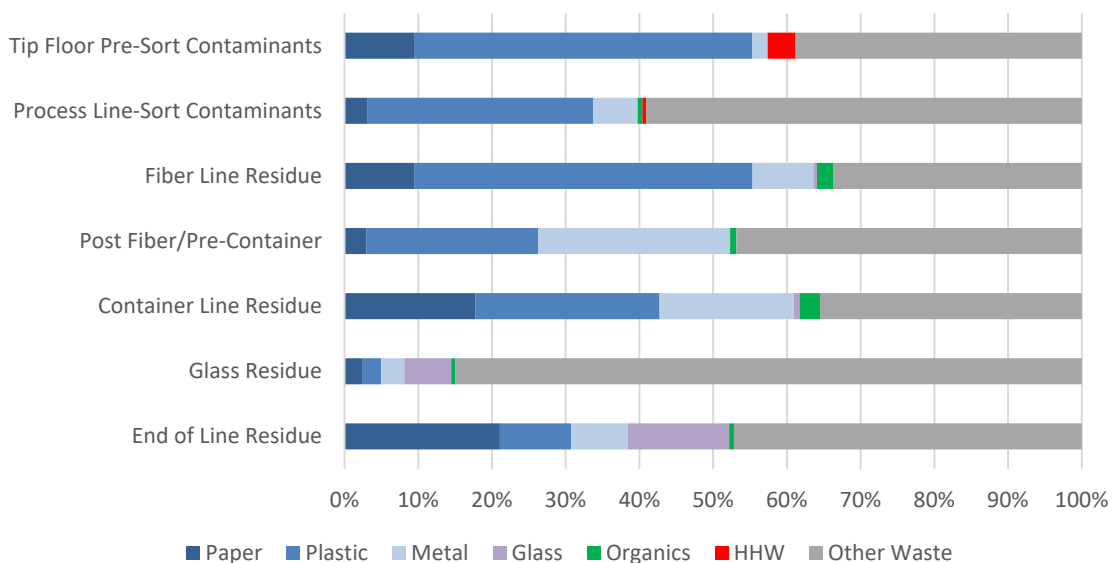
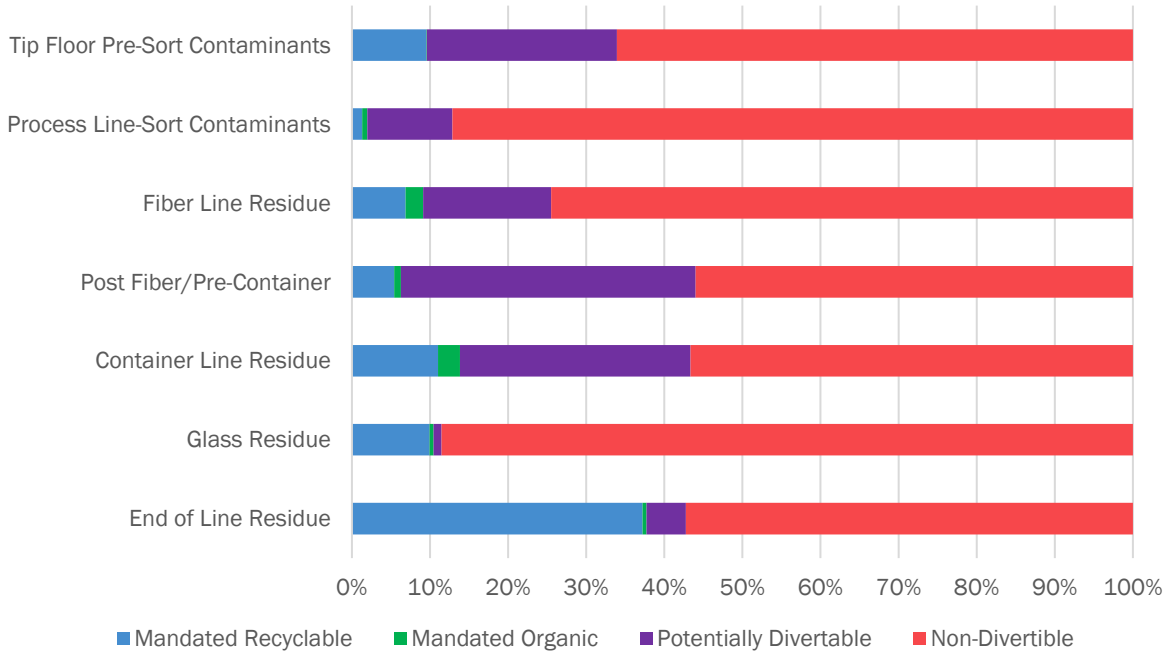

Figure 5-5 compares the divertibility of MRF residue by source. This figure highlights that small quantities of targeted recyclables are lost from every ejection point. This finding highlights the issue of material

5. MRF RESIDUE COMPOSITION

quality (cleanliness/food contaminated, saturation, etc.) and possibly the opportunity for marginal improvements in processing technology that may incrementally increase the recovery of targeted recyclables in the future.

Figure 5-5 Comparison of MRF Residue Divertibility by Source



The top ten most prevalent materials identified in the residue composition are provided in Figure 5-6.

As shown, other wastes (textiles, wood, furniture, books, etc.), film plastic, 2-inch minus materials (fines, lids/caps, crushed glass, etc.), and bagged material comprise over 66 percent of the residue.

Figure 5-6 Top Ten Most Prevalent Materials

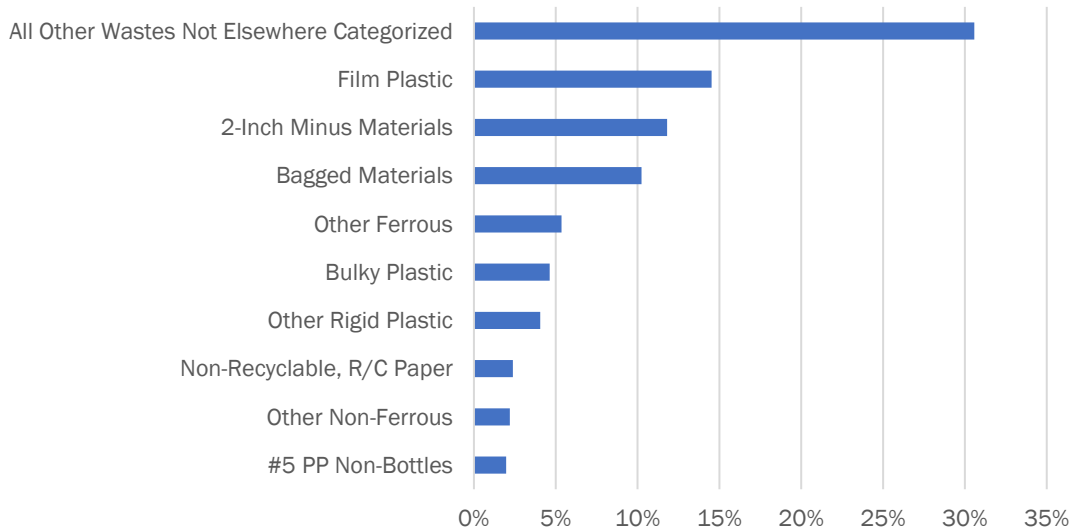

5. MRF RESIDUE COMPOSITION

The results by major material groups are shown in Figure 5-7, Figure 5-8, Figure 5-9, and Figure 5-10. As shown, the most prevalent material(s) in each material group are those identified as non-divertible or potentially divertible in Table 5-3.

Figure 5-7 Plastic Materials Observed in Residue

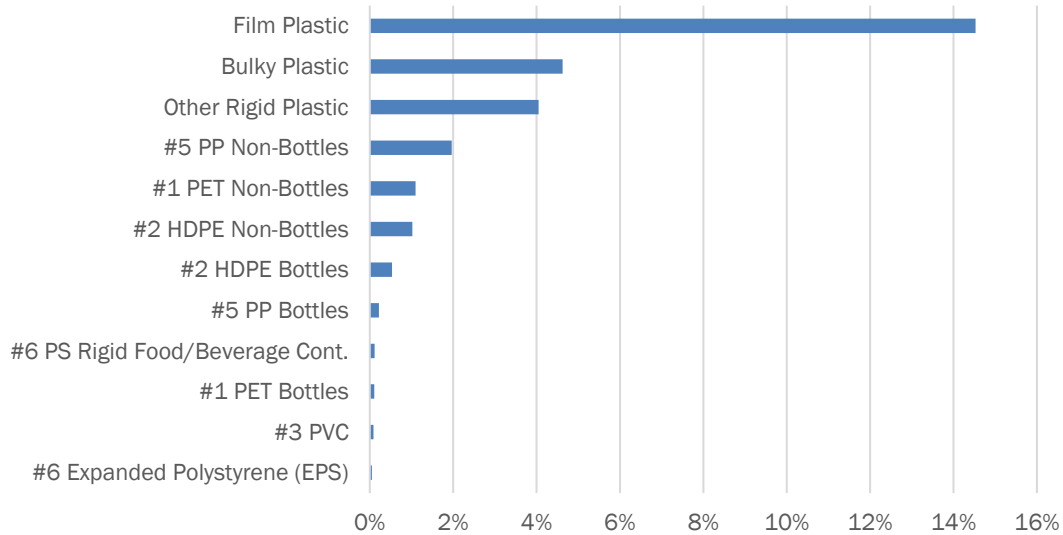
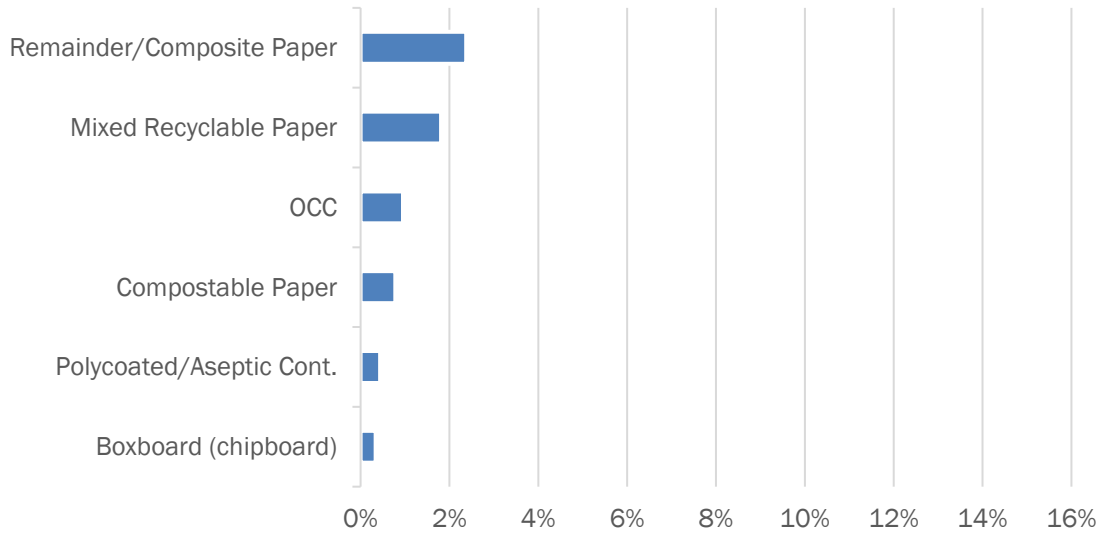

Figure 5-8 Paper Materials Observed in Residue



5. MRF RESIDUE COMPOSITION

Figure 5-9 Metal Materials Observed in Residue

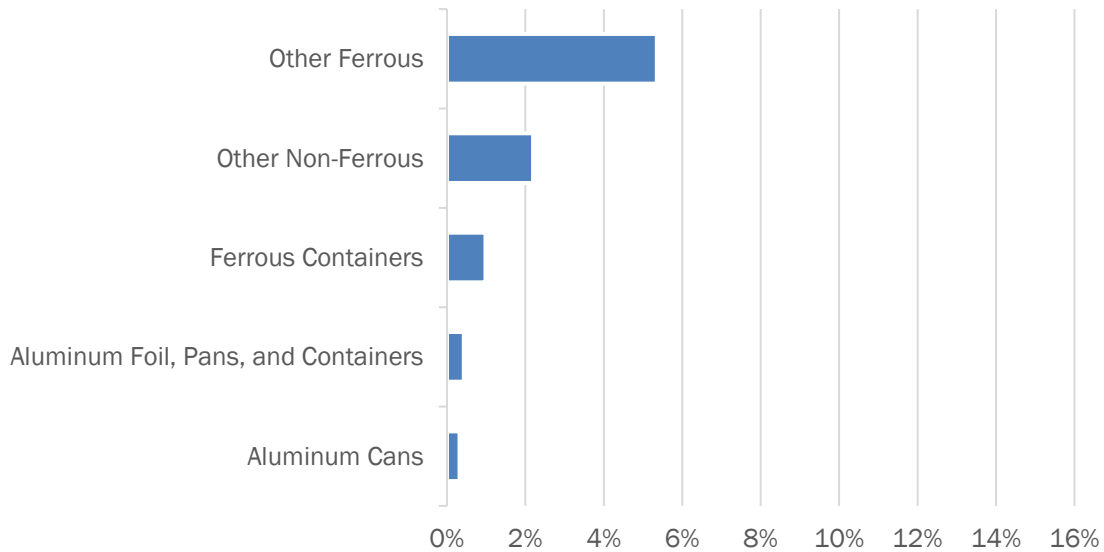

Figure 5-10 Other Materials Observed in Residue

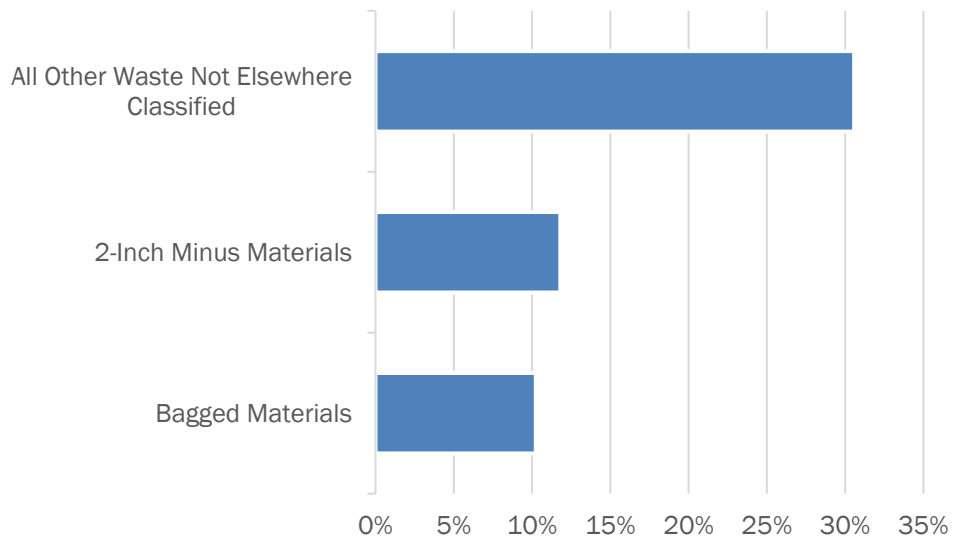

Table 5-5 provides the detailed composition for each of the discrete ejection points identified and measured in this study. Further insights can be observed in this data; however, it should be noted that the underlying sample size for all these ejection points is small. Although these results are derived from representative sampling of homogenous materials from an industrial process line and appear reasonable in the professional opinion of MSW Consultants, readers should not assume that the same composition would be obtained at other MRFs outside of those included in the study. The Vermont Aggregate column represents the estimated statewide MRF residue composition using the results at each ejection point weighted by the breakout of total residue in Figure 5-1.

5. MRF RESIDUE COMPOSITION

Table 5-5 Residue Composition by Ejection Point

Material Description	Tip Floor	Process Line		Post	Container	End of		Vermont
	Pre-Sort Contam.	Pre-Sort Contam.	Fiber Line Residue	Fiber/Pre- Container	Line Residue	Glass Residue	Line Residue	
OCC	5.6%	0.3%	0.5%	0.2%	1.3%	0.0%	1.0%	1.0%
Boxboard (chipboard)	0.7%	0.1%	0.2%	0.1%	1.5%	0.0%	1.3%	0.3%
Mixed Recyclable Paper	2.2%	0.6%	2.3%	0.4%	3.0%	1.3%	11.7%	1.8%
Polycoated/Aseptic Containers	0.1%	0.0%	1.0%	0.0%	3.5%	0.0%	0.0%	0.4%
Compostable Paper	0.9%	0.8%	1.4%	0.1%	0.4%	0.4%	2.4%	0.8%
Remainder/Composite Paper	0.1%	1.4%	4.1%	2.2%	8.1%	0.7%	4.6%	2.4%
#1 PET Bottles & Jars	0.2%	0.0%	0.2%	0.2%	0.3%	0.0%	0.1%	0.1%
#1 PET Other Containers	0.6%	0.2%	3.6%	2.2%	2.6%	0.0%	1.0%	1.1%
#2 HDPE Bottles & Jars	0.0%	0.0%	1.4%	1.1%	0.9%	0.0%	2.6%	0.5%
#2 HDPE Other Containers	0.1%	0.3%	0.9%	4.3%	2.4%	0.0%	0.7%	1.0%
#3 PVC	0.0%	0.0%	0.1%	0.3%	0.1%	0.0%	0.2%	0.1%
#5 PP Bottles & Jars	0.0%	0.0%	0.4%	0.6%	0.8%	0.0%	0.2%	0.2%
#5 PP Other Containers	0.1%	0.3%	3.9%	5.1%	6.8%	0.1%	2.0%	2.0%
#6 PS Rigid Food/Beverage Cont.	0.0%	0.0%	0.8%	0.0%	0.2%	0.0%	0.1%	0.1%
#6 Expanded Polystyrene (EPS)	0.0%	0.1%	0.1%	0.0%	0.1%	0.0%	0.0%	0.0%
Film Plastic	17.6%	21.8%	30.9%	0.9%	2.8%	0.0%	0.4%	14.5%
Other Rigid Plastic	4.8%	3.5%	3.2%	5.7%	6.2%	2.3%	2.3%	3.9%
Bulky Plastic	22.3%	4.4%	0.3%	2.9%	1.8%	0.0%	0.0%	4.6%
Aluminum Cans	0.3%	0.1%	0.2%	0.1%	0.4%	0.3%	2.6%	0.3%
Aluminum Foil, Pans, and Containers	0.1%	0.0%	0.7%	0.1%	0.4%	0.7%	3.7%	0.4%
Ferrous Containers	0.5%	0.2%	0.9%	3.2%	2.4%	1.2%	0.4%	1.0%
Other Ferrous	1.1%	4.6%	5.1%	12.1%	12.0%	0.8%	0.8%	5.4%
Other Non-Ferrous	0.1%	1.0%	1.3%	10.5%	3.0%	0.1%	0.2%	2.2%
Glass	0.1%	0.0%	0.5%	0.1%	0.8%	6.4%	13.7%	1.6%
Food Waste	0.0%	0.6%	2.2%	0.9%	2.8%	0.5%	0.5%	1.0%
Batteries	0.0%	0.0%	0.0%	0.0%	0.0%	0.0%	0.1%	0.0%
Other HHW	3.8%	0.5%	0.0%	0.0%	0.0%	0.0%	0.0%	0.6%
All Other Wastes	33.0%	36.5%	26.0%	45.8%	31.8%	2.4%	6.5%	30.6%
2-Inch Minus Materials	2.6%	0.8%	1.2%	1.0%	2.4%	82.6%	40.7%	11.8%
Bagged Materials	3.1%	21.8%	6.5%	0.0%	1.3%	0.0%	0.0%	10.2%
TOTALS:	100.0%	100.0%	100.0%	100.0%	100.0%	100.0%	100.0%	100.0%
<i>Mandated Recyclable</i>	9.5%	1.3%	6.9%	5.4%	11.0%	9.9%	37.2%	7.0%
<i>Mandated Organic</i>	0.0%	0.6%	2.2%	0.9%	2.8%	0.5%	0.5%	1.0%
<i>Potentially Divertable</i>	24.3%	10.9%	16.4%	37.7%	29.5%	1.0%	5.0%	16.6%
<i>Non-Divertible</i>	66.1%	87.1%	74.5%	56.0%	56.6%	88.5%	57.2%	75.4%

5.3 TUBS & LIDS COMPOSITION

Although not originally part of the planned field research, DEC requested, and MSW Consultants was able to accommodate, sampling and analysis of sorted plastic Tubs and Lids from both participating MRFs.

A total of eight (8) samples of post facility sort, pre-baler plastic Tubs and Lids were obtained, four (4) from each MRF. At one MRF the facility staff was able to drop tubs & lids from the chute down on the conveyor that goes directly to the baler. Through an access door to the conveyor, MSW staff shoveled the material off the conveyor into sample barrels. At the other MRF, a skid steer was able to go into the tubs and lids bunker to retrieve material and bring this material to MSW staff to weigh out a sample. Table 4-6 provides the estimated composition of sorted Tubs and Lids based on an equal-weighted analysis of the eight (8) samples. No attempt was made to determine if certain samples should be over or underweight; nor does this analysis purport to be representative of the composition of tubs and lids statewide. The data is presented primarily because very little similar data or analysis on tubs and lids is available in industry literature. Material categories for the tubs and lids sort was somewhat different than the residue material categories so no category numbers have been assigned in this table to avoid confusion for the reader.

5. MRF RESIDUE COMPOSITION

Table 5-6 Detailed Composition of Plastic Tubs and Lids

Material Category	Mean	Material Category	Mean
Paper	1.6%	Metal	0.5%
1 OCC	0.3%	16 Aluminum Cans	0.3%
2 Boxboard (chipboard)	0.2%	17 Aluminum Foil, Pans, and Containers	0.2%
3 Mixed Recyclable Paper	0.2%	18 Ferrous Containers	0.0%
4 Polycoated / Aseptic Cont.	0.3%	19 Other Ferrous	0.0%
5 Compostable Paper	0.0%	20 Other Non-Ferrous	0.0%
6 Non-Recyclable, R/C Paper	0.8%	Organics	0.2%
Plastic	96.1%	21 Food Waste	0.2%
7 #1 PET	5.2%	HHW	0.0%
8 #2 HDPE	16.3%	22 Batteries	0.0%
9 #3 PVC	0.2%	23 Other HHW	0.0%
10 #5 PP	70.1%	Other Waste	1.6%
11 #6 Expanded Polystyrene (EPS)	0.9%	24 All Other Wastes Not Elsewhere Categorized	0.4%
12 #6 Expanded Polystyrene (EPS)	0.0%	25 2-Inch Minus Materials	1.2%
13 Film Plastic	0.1%	26 Bagged Materials	0.0%
14 Other Rigid Plastic	3.5%		
Glass	0.0%		
15 Glass	0.0%	Total	100.0%

 Mandated Recyclable	 Non-Divertible at MRF
 Mandated Organic (Non-Divertible at MRF)	 Potentially Divertible at MRF

5.4 SUPPLEMENTAL OBSERVATIONS

As stated above, a primary observation is that the Vermont MRFs residues, as a percent of incoming material, were at the low end of the range for residue generation based on national literature (and on the Project Team’s work at other MRFs processing single-stream material).

Ultimately, both people and machines are fallible in their sorting abilities. “Wish recycling” of nonrecyclable materials complicates the recovery of mandated recyclables by requiring manual sorting to eliminate these materials before they cause problems in the sorting lines. Further, materials degrade as they are collected, compacted in the body of a collection truck, tipped on a cement floor, moved by loaders and other rolling stock at the MRF, and processed across industrial conveyors and through various trommels and screens during the sorting process. Such degradation reduces the particle size of some recyclables, and tends to disperse liquids into the fiber, making individual recyclable items harder to identify, recover, and sort.

Further, the host MRFs and many other MRFs known to the Project Team knowingly lose certain potentially targeted recyclables due to technology limitations and because the economics of incrementally higher recovery are not favorable under current business conditions. For example, it was qualitatively observed that many of the rejected plastics (i.e., those in the container line stream) were black plastic #1s and #5s, which are not recognized by most optical sorters, and often are not desired by end markets.

Similarly, space constraints at older MRFs create problems when optimizing a recovery line. Removal of contaminants requires sorting resources and storage space, both of which may not physically fit within older, smaller buildings. In this study, space constraints limited the ability of both MRFs to equally pre-sort and recover bulky items like metal and bulk plastics. One of the host MRFs reported that it is due for a redesign, which would presumably change their processing configuration and result in a different residue composition profile.

5. MRF RESIDUE COMPOSITION

However, in conclusion, it is the professional opinion of the Project Team, that the findings in this section are consistent with other MRFs in the U.S. and find that the residue being disposed from Vermont's MRFs contains very little mandated recyclable materials (0.7 percent of all incoming loads, or 469 tons) and an even lower fraction of bottles, jars, and cans (0.4 percent of all incoming loads, or 248 tons).

6. RESIDENTIAL FOOD SCRAP MANAGEMENT RESEARCH

6.1 OVERVIEW

Project Team member DSM, which managed the food scrap research in the 2017 Study (contained in the 2018 Waste Characterization Report), reprised this role for the 2023 update. DSM collaborated with the University of New Hampshire (UNH) Survey Center to perform the 2023 questionnaire of Vermont households to measure residential food waste disposal behaviors, and particularly to estimate participation in backyard composting of food waste. The questionnaire in the 2023 Study asked essentially identical questions to the 2017 survey, although the prior research was conducted by the Castleton Polling Institute (CPI), and several questions were refined based on the experience of the previous survey.

It is noteworthy that the residential questionnaire methodology was updated to relatively new best practices which have evolved since the prior study. In 2017, CPI surveyed a random selection of Vermont households directly through various media. In 2023, at the UNH Survey Center's recommendation, the questionnaire was administered to a preselected panel of Vermonters chosen to be representative of Vermont demographics. The panel agreed to participate in various UNH research efforts. UNH believes that the panel-based methodology provides similar representation as the direct random sample methodology but is more reliable and cost effective given the changes to residential landline and cell phone usage, as well as societal communication behaviors.

Appendix C contains the complete report from the UNH Survey Center, including specifics of the research methodology and detailed results. This section summarizes the results and compares the results to the previous survey results. It also attempts to further quantify the various ways respondents specified that they diverted food waste from disposal; and integrates the questionnaire findings with the waste characterization results to estimate residential food waste generation, diversion, and disposal to compare to disposal data from other states.

6.2 ESTIMATED DIVERSION OF RESIDENTIAL FOOD WASTE FROM DISPOSAL IN VERMONT

Figure 6-1 summarizes responses from households concerning their management of household food waste. Because the responses in terms of how food waste is managed are not mutually exclusive, it is necessary to estimate quantities of food waste diverted by each method based on the questionnaire data. It should be noted that these estimates by type of diversion are necessarily best professional judgements, with the attempt to subjectively compare food waste *generation* with food waste *disposal* based on the results of the waste characterization analysis and the responses from the residential food waste questionnaire of behavior.

A series of assumptions are necessary to quantify the household responses because the questionnaire data represents reported behavior and are not quantifiable in and of itself. These assumptions, based on significantly much more quantifiable data on materials recycling behavior, significantly reduce the gross calculations contained in the UNH Survey Center report, which simply assumed 100 percent diversion for each category based on an average volume of food waste diverted times the percent of households reporting each type of diversion.

As was the case in developing the UNH questionnaire, the original Castleton survey was modified by the Project Team and UNH to better understand diversion other than backyard composting. While these results are more descriptive, it is clear that if the questionnaire were to be duplicated during the next waste characterization study it would be useful to further modify the questions to drill down with respect to what percent of food waste is diverted by each alternative the responding households use.

6. RESIDENTIAL FOOD SCRAP MANAGEMENT RESEARCH

Figure 6-1 Reported Disposition of Residential Food Waste

Figure 10a: What does your household do with food waste that comes from eating or preparing food including any scraps, inedible parts, and spoiled or rotten foods? (Select all that apply)

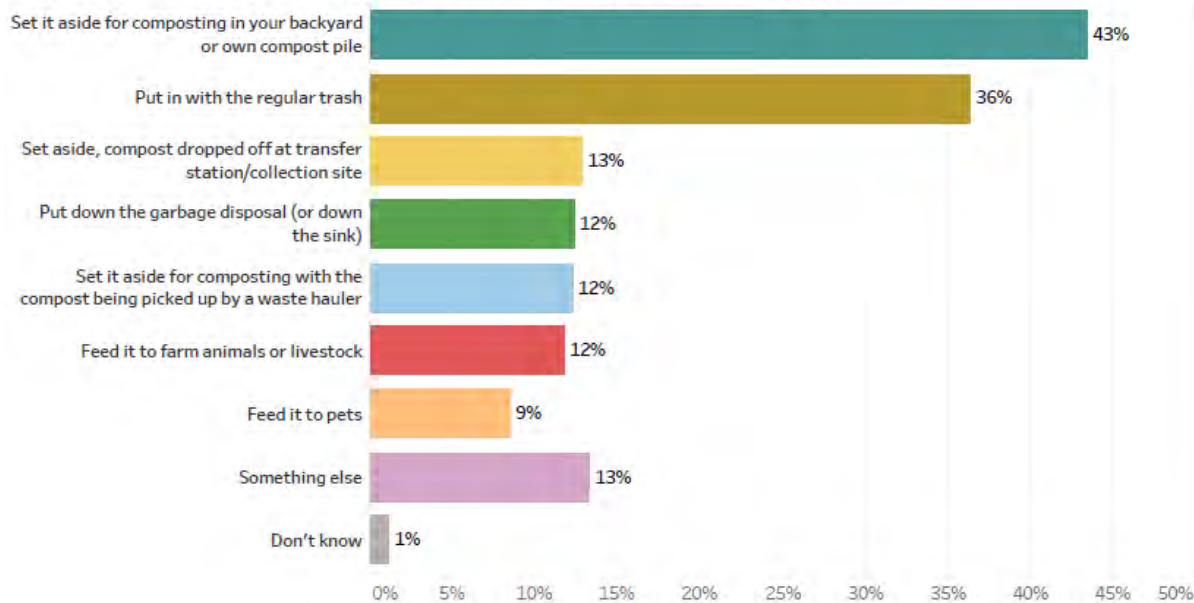

Source: Figure 10a, Appendix C.

To prepare estimates of diversion by method, and subsequently, estimated total diversion of food waste from disposal, DSM has made the following key assumptions:

- **Vermont Population and Households:** 647,047 and 277,090, respectively.¹
- **Weekly Food Waste Diversion Rates:** Two gallons per week per household, weighing 8.3 pounds (4.15 pound per gallon). This amount is based on a rough average of the reported volume from the 2023 questionnaire data converted to weight based on weight data from three ecomaine communities who participated in curbside collection pilots.² It is also consistent with the 2017 Castleton Polling Institute data. This 8.3 pounds per week multiplied by 52 weeks in a year result in an estimate of 431.6 pounds per year per household.
- **Food Waste Capture Rates:** the percentage of potential set outs of food scraps to the chosen diversion alternative, estimated as follows:
 - *Backyard Composting:* 70 percent. This assumes meat scraps are not composted, and backyard composting is reduced during the winter months.
 - *Subscription Curbside Collection:* 80 percent, given that households who contract for collection pay a significant price for the service and are therefore motivated to participate.
 - *Drop-off Programs and Collection Sites:* 60 percent. Measured diversion rates for drop-off recycling are significantly below diversion rates for curbside programs.

¹ US Census, 2022 estimates

² *Analysis of Costs Associated With Separate Collection of Food Waste From Ecomaine Member Municipalities*, DSM Environmental Services, February 2018.

6. RESIDENTIAL FOOD SCRAP MANAGEMENT RESEARCH

- *Farm Animal Feed*: 50 percent. It is assumed that chickens are the primary farm animal, and they consume only vegetable wastes, exclusive of citrus peelings, rinds, and some vegetative waste not palatable to chickens.
- *In-sink Garbage Disposers*: 50 percent. Cannot be used on all foods due to restrictions on size, meat and bones, citrus, and some fibrous materials.
- *Fed to Pets*: 20 percent. It is assumed that primarily meats and post-plate food scrapings could be reused in this manner.
- *Something Else Not Shown*: 30 percent. There was no follow-up to this question, so it is pure speculation about what this implies. It probably means disposal in many cases, although several answers included throwing it in the woods outside their house, or essentially just piling it in some location on their property – essentially a form of composting. In addition, it is likely that in some cases it is brought to a food waste dumpster at work.

Table 6-1 applies these assumptions to estimate annual tons diverted by each reported type of diversion, as well as total estimated statewide household diversion. The percentage of reporting households for each diversion method was multiplied by the total number of Vermont households (277,090) to calculate the number of households using a diversion method. The assumed capture rate for each method was multiplied by the estimated 431.6 pounds per year per household to calculate the pounds diverted per household. The total tons were then calculated by multiplying the number of households by the pounds diverted per household. As shown, it is estimated that over 38,000 tons of residential food is diverted through the myriad of options available.³

Table 6-1 Estimated 2023 Diversion of Residential Food Waste

Diversion Method	% Households Reporting	No. of Households	Assumed Capture Rate	Lbs/HH Diverted	Tons Diverted
Backyard Composting	43%	119,149	70%	302	17,999
Collection By Hauler	12%	33,251	80%	345	5,740
Drop-off/Collection Site	13%	36,022	60%	259	4,664
Fed to Animals	12%	33,251	50%	216	3,588
In-Sink Garbage Disposal	12%	33,251	50%	216	3,588
Fed to Pets	9%	24,938	20%	86	1,076
"Something Else"	13%	36,022	30%	129	2,332
Total					38,987

The diverted food waste tonnage can be combined with the estimated amount of food waste disposed in the residential waste stream (see Section 2) to estimate total residential food waste generation, as well as per capita values. These calculations are shown in Table 6-2. As shown, these data suggest that 230 pounds per capita are generated annually, of which roughly half is diverted.

³ It should be noted that there is meaningful uncertainty associated with this estimate, but due to the nature of the estimate, it is not possible to construct statistically valid confidence intervals.

6. RESIDENTIAL FOOD SCRAP MANAGEMENT RESEARCH

Table 6-2 Estimated Residential Food Waste Diversion and Disposal (2023)

Pathway	Annual Tons	Percent of Total	Per Capita (lbs)
Diverted	38,987	52.3%	120
Disposed (see Table 2-3)	35,520	47.7%	110
<i>Food Waste, Unpackaged</i>	20,275		
<i>Food Waste Contained in Packaging</i>	15,245		
Total	74,507		230

Comparable residential food waste generation data are hard to come by – either nationally or per state. However, ReFED, a national nonprofit dedicated to ending food loss and waste, has expended significant effort compiling data about food waste generation. ReFED reports an estimated 42.8 million tons of food waste generated by residential households each year in the US. With a US population of 331.5 million (2020 US Census), this translates to 258 pounds of food waste per person per year.⁴ It is of particular interest that the above Vermont-specific estimates are within ten percent of the ReFED implied per capita generation. Given the level of assumptions necessary to estimate VT per capita food waste diversion, the comparison would indicate that the responses to the UNH questionnaire are probably an accurate description of the behavior of Vermonters to food waste diversion and disposal. This finding further implies that roughly one-half of all Vermont residential food waste is going someplace other than to disposal.

6.3 COMPARISON OF 2017 & 2023

The results of the 2023 questionnaire are consistent with the results of the 2017 survey results.

- In 2017, 58 percent of households reported diverting some portion of their food waste. In 2023, 64 percent of households reported diverting some portion of their food waste. Given the likely margin of error in reported behavior, this difference is relatively insignificant; and the more detailed questions on types of diversion this time could contribute to a higher reported percent of households diverting some portion of food waste.
- Quantities diverted, based on volume estimates derived from the questionnaires, were essentially the same for 2023 as for 2017. As such, the calculations in Table 5-1 above use the same 8.3 pounds per household per week diversion estimate.
- The 27,579 tons estimated to be diverted in 2017 (as reported in the 2018 Waste Characterization Report) were significantly lower than the estimate of 39,000 (rounded) tons estimated in this update. This increase in estimated diversion is partially due to a more granular estimate of diversion in this study based on the expanded list of diversion options, rather than a change in actual diversion. However, the change in estimated per capita disposal from 130 pounds per capita in 2017 (see Table 5-3 below) to 110 pounds per capita in 2023 indicates that the landfill ban has increased diversion of residential food waste in Vermont through a combination of increased backyard composting, and alternative diversion options, as discussed below.

On a related note, the similarity and reasonableness of the panel-based residential behavior research methodology was impressive to the Project Team. This innovative approach appears to overcome shortfalls with older, direct-survey methods as performed in 2018. Should the state wish to update its understanding of residential recycling and organics management behavior in the future, the 2023 panel-based methodology offers a compelling value.

⁴ https://refed.org/food-waste/the-problem/#what_is_food_waste.

6. RESIDENTIAL FOOD SCRAP MANAGEMENT RESEARCH

6.4 IMPACT OF VERMONT'S LANDFILL BAN ON FOOD WASTE DISPOSAL

Table 6-3 below carries forward Table 2-4 (*Comparison of Per Capita Food Waste Disposal, Vermont, Delaware, Rhode Island, and Connecticut*) from the 2018 Waste Characterization Report, but with the most recent (2023) VT residential disposal data added. As illustrated, the landfill food waste ban does appear to have had an impact (a roughly 15 percent reduction) on *residential* food waste disposal in Vermont.

Table 6-3 Comparison of Per Capita Residential Food Waste Disposal

State	Lbs/Capita	Date
Delaware	137	2016
Connecticut	152	2015
Rhode Island	115	2015
Vermont	130	2017
Pennsylvania	117	2021
Vermont	110	2023

6.5 LIMITATIONS

As stated in the 2018 Waste Characterization Study, it should be cautioned that self-selection bias and socially desirable behavior bias continue to exist in questionnaires where respondents describe their recycling behaviors. However, it is likely that self-selection bias has been reduced by the fact that the Vermont panel was selected by UNH well in advance of this research and was constructed to conduct questionnaires on a wide range of issues, including in this case management of food waste at the household level.

Similar to the 2018 Report, no adjustment was made to account for self-selection bias because there continues to be no obvious methodology for making such an adjustment. This is, in part, because there does not appear to be any data from other similar studies that can be used to compare and adjust the Vermont questionnaire data. While there are data from a number of studies in other states concerning quantities of residential food waste disposed (much of the New England data coming from other MSW/DSM statewide waste characterization studies), the Project Team is not aware of studies in other states associated with the behavior of households with respect to backyard composting and animal feeding.

However, as presented in the findings above, it appears that a majority of households in Vermont are diverting a significant amount of food waste from disposal, and that diversion has increased by roughly 15 percent since the last Waste Characterization Study.

6. RESIDENTIAL FOOD SCRAP MANAGEMENT RESEARCH

This page is intentionally left blank.

7. ORGANICS MANAGEMENT TRANSPORTATION RESEARCH

7.1 INTRODUCTION & SUMMARY

The Vermont Universal Recycling Law, enacted in 2012, established a phase-in schedule for banning food scraps from landfill disposal beginning July 1, 2014, as shown in Table 7-1.

Table 7-1 Food Scrap Landfill Ban Timeline

Year	Targeted Generator	Restrictions
2014	Generators of 104 tons/year (2 tons/wk)	Located within 20 miles of a certified processing facility
2015	Generators of 52 tons/year (1 tons/wk)	Located within 20 miles of a certified processing facility
2016	Generators of 26 tons/year (1/2 ton/wk)	Located within 20 miles of a certified processing facility
2017	Generators of 18 tons/year (1/3 tons/wk)	Located within 20 miles of a certified processing facility
2020	All commercial and residential generators	None

Since July 1, 2020, food scraps, other than de minimis quantities, have been entirely banned from landfill disposal. DEC requires any transporters of solid waste including food scraps to be permitted. Further, organics processing facilities report the quantity of food scraps received, enabling measurement of a significant fraction, and likely the majority, of diverted food scraps (exclusive of on-site composting and diversion).

However, not all food scraps are processed at reporting Vermont facilities and transporters, though required to be permitted, do not report to DEC. It is known that unreported food scrap diversion occurs when food scraps are taken to facilities outside of Vermont, are delivered to on-farm facilities and animal feeding operations, or possibly donated for rescue. Some on-farm facilities process organics but these facilities do not report to DEC. To further advance awareness of food scrap generation and diversion, the 2023 Study incorporated new research into non-residential food scrap management. This section describes the research protocol and findings.

In summary, through a series of questionnaires, the Project Team estimates that 4,756 tons of food scraps are being diverted annually to out-of-state facilities or in-state uses (such as animal feeding operations and farms) that are not reported to Vermont DEC. This additional “organics management transportation research” figure is incorporated into the Food Scrap Recovery Rate found in the Conclusions and Recommendations Section of this report.

7.2 METHODOLOGY

The Project Team undertook the following steps to research food scrap generators and registered food scrap transporters:

- Developing questionnaires and introductory information for each outreach population (generators and transporters) explaining the research and the data being sought, including a statement by the DEC authorizing the project and asking for cooperation.

7. ORGANICS MANAGEMENT TRANSPORTATION RESEARCH

- Preparing both online and form-based versions of the questionnaires. The questionnaire forms for Food Scrap Generators and Food Scrap Transporters can be found in Appendix B.
- Obtaining the list of 37 permitted food scrap transporters from DEC.
- Compiling a list of businesses and institutions that generate food scraps, drawing from a 2018 list of businesses with economically driven food scrap recycling, as well as from a search of the Vermont Department of Labor database for the largest employers located in the state in industries associated specifically with food scrap generation (restaurants, retailers, manufacturers, etc.) A total of 410 potential food scrap generators made this list.
- Having DEC distribute the initial online questionnaire in hopes that it might go to fewer junk or spam folders than if coming from a consultant or third-party blast email address.
- Engaging the Vermont Retail and Grocers Association (VRGA) to send the online questionnaire link to their membership, which numbers approximately 550 members based on their website.
- Systematically following up with all recipients.

Industry categories were used to classify the business type to better understand food scrap management trends within each industry sector. Industry categories used were:

- **Institutions** – represents universities, medical facilities or any other institutions located within Vermont that employ more than 250. Institutions frequently have cafeterias and would generate food scraps.
- **Manufacturing and Wholesale** – includes companies located in Vermont who manufacture or wholesale materials or goods and employ more than 100 people. Companies operating within these industries may generate food scraps depending on what product(s) they manufacture, and/or if they have an onsite cafeteria.
- **Recyclers** – companies in and surrounding Vermont that may be involved in managing food scraps, including rescue or reuse of materials.
- **Restaurants** – fast- or full-service restaurants as well as catering and food manufacturers identified on the VT Department of Labor website to either have more than 250 employees or numerous locations within VT.
- **Retail** – represented big-box stores, department stores, and grocers. Depending on the services offered, retail stores generate food scraps as well as traditional recyclable materials (as discussed in section 7).

As a final step, outreach and responses were summarized. It is noted that no attempt has been made to extrapolate to the entire population of statewide generators. Due to the immense universe of food generators, the research was focused on generators known to have 250 or more employees, or that were identified in the Department of Labor information to have numerous locations in the state, such as restaurant and retail chains.

7.3 RESPONSE RATES

7.3.1 FOOD SCRAP GENERATORS

Table 7-2 shows the outreach outcome of the food scrap generator questionnaires by industry category. As shown, MSW attempted to contact a total of 410 generators and was able to reach 186 locations for which information was provided or questionnaires completed, for a 41 percent response rate. Of the 168 responses, 146 reported using a hauler for collection and no tonnage information was available.

7. ORGANICS MANAGEMENT TRANSPORTATION RESEARCH

Table 7-2 Food Scrap Generator Questionnaire Response Summary

Outreach Outcome	Institutions	Manufacturing & Wholesale	Recyclers	Restaurant	Retail	Total
Completed Questionnaire – YES	18	5	4	106	53	186
Business Closed/Participation Declined	1	5	0	11	3	20
Multiple Attempts Made/No Response Received	11	12	0	126	55	204
Total Outreach Population	30	22	4	243	111	410
<i>Response Rate</i>	60.0%	22.7%	100.0%	43.6%	49.1%	47.7%

7.3.2 FOOD SCRAP TRANSPORTERS

Table 7-3 shows the breakdown of food scrap transporter questionnaire respondents by response type. As shown, 19 of the 37 permitted food scrap hauling companies provided some data or completed questionnaire forms for a response rate of 51 percent.

Table 7-3 Food Scrap Transporter Questionnaire Response Summary

Status	Food Scrap Transporters
Outreach Population	37
Completed Questionnaires with tonnages	19
Contacted 3 Times or More, Questionnaire Not Completed	18
<i>Response Rate</i>	51%

Although not shown in the table, the Project Team can report that two respondents are known to be relatively large organizations and are likely transporting a significant fraction of the state’s organics.

7.4 RESEARCH RESULTS

7.4.1 DIRECT DISPOSITION & BACKHAUL OF FOOD SCRAPS BY GENERATORS

Table 7-4 summarizes the data obtained from food scrap generators who do not rely on a third-party, permitted hauler to collect their food scraps. The data reported is from confirmed respondents only and is not extrapolated beyond the responses received as this could lead to double counting through the corresponding Food Scrap Transporter research. The most prevalent destination of food/food scraps being diverted without collection by permitted haulers was found to be donation to local food banks, though volumes were not quantifiable by the generators. DEC confirmed that the Vermont Foodbank reports to them annual rescue and donations received. Thus, the Foodbank data is not included in this section. Other food scraps were diverted without enlisting a permitted hauler because they were backhauled or else delivered directly to an outlet by the generator. Most directly diverted food scraps were found to be source separated. DEC and the Project Team note that food waste reported to be diverted to farm composters or animal feeding operations may be causing some generators to report one or the other of these categories depending on how they view the farm activity. Some farm-based composters are also allowing chickens access to food scrap/compost materials, which some generators may describe as “animal feeding.”

7. ORGANICS MANAGEMENT TRANSPORTATION RESEARCH

Table 7-4 Direct Food Scrap Diversion Reported by Vermont Generators (2022 Tons)

Food Scrap Condition	Pathway	Tons
Source Separated Scraps		611.1
	Compost facility	16.6
	Farm composter	311.6
	Depackaging facility	102.1
	Anaerobic digester	0.0
	Animal feeding operation	93.5
	Other ^[1]	87.3
Packaged Scraps		1,416.2
	Compost facility	0.8
	Farm composter	0.0
	Depackaging facility	0
	Anaerobic digester	1,415.5
	Animal feeding operation	0.0
	Other	0.0
Unknown		10.0
	Total	2,037.4

^[1] "Other" includes destinations such as backyard compost.

Figure 7-1 combines source separated and packaged tons, and (excluding donation) shows that anaerobic digesters is the most common outlet for these generators, followed by farm composters, depackaging facilities, animal feeding operations, and other uses. Very little food waste was reported going directly to regulated organics processing facilities. Retail and institutional generators were the primary responders, accounting for over 95 percent of the provided tonnage. From discussions with DEC, it is likely that there is data missing from this analysis, such as significant volumes of liquid food processing residuals from food manufacturers that is not tracked here as going for anaerobic digestion in and out of state.

7. ORGANICS MANAGEMENT TRANSPORTATION RESEARCH

Figure 7-1 Direct Food Scrap Diversion Pathways Reported by Vermont Generators

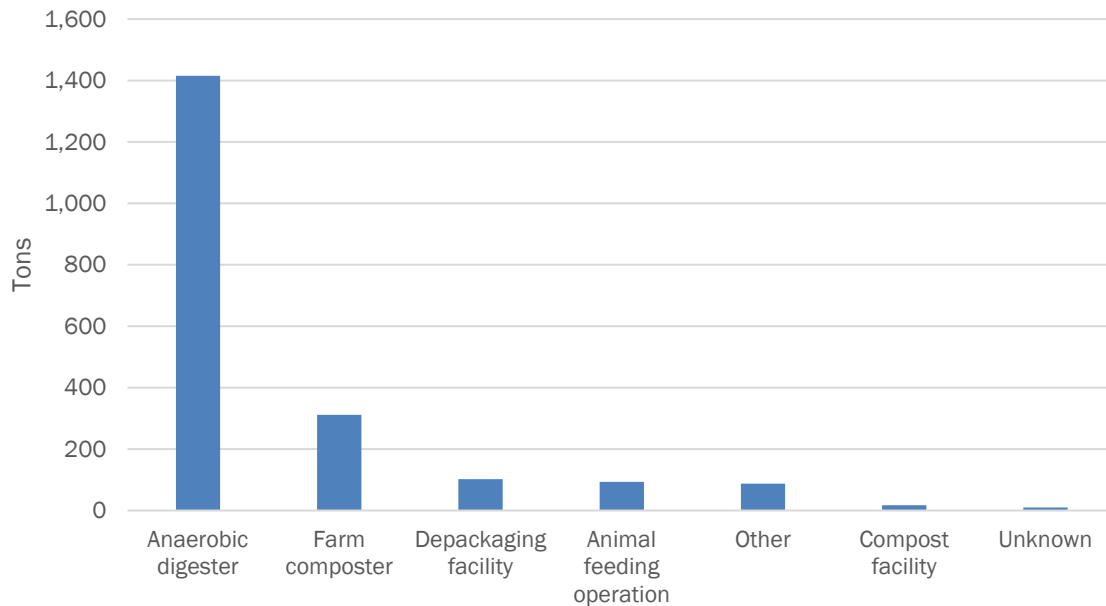

7.4.2 FOOD SCRAP TRANSPORTERS

Table 7-5 summarizes the data provided by the Vermont permitted organics transporters that responded to the questionnaire. Though individual responses are kept confidential, the Project Team is aware that the largest-volume transporters were responsive and therefore these reported quantities include the majority of transported food scrap tons.

Although 18 permitted transporters did not submit responses to the research, DEC has reviewed these results and believes that these responses capture the majority of food scraps transported by permitted haulers. The Project Team applied deductive reasoning to arrive at a likely range of additional food scraps being transported by the non-respondents. First, we removed the largest and smallest transporters as high-end and low-end outliers, respectively. Then we calculated the average of the remaining directly reported transport quantities, as well as the confidence intervals at a 90 percent level of confidence. In this way, it was found that the likely upper bound of unreported food scraps being transported was 10,891 tons (605 tons per non-respondent), and the lower bound was 2,391 tons (133 tons per non-respondent). These amounts have been added to the data received from the questionnaire respondents as the likely range of transported food scraps in Table 7-5.

7. ORGANICS MANAGEMENT TRANSPORTATION RESEARCH

Table 7-5 Estimated Food Scrap Transportation by Food Type and Pathway

Food Scrap Condition	Pathway	2022 Reported Tons		
		VT Facility	Out-of-State Facility	Total
Source Separated Scraps		13,003	59	13,062
	Compost facility	6,288	<u>59</u>	6,347
	Farm composter	993		<u>993</u>
	Depackaging facility	4,914		4,914
	Anaerobic digester			0
	Animal feeding operation	807		<u>807</u>
	Other ^[1]	1		<u>1</u>
Packaged Scraps		5,295	2,896	8,191
	Compost facility	600		600
	Farm composter			0
	Depackaging facility	4,695		4,695
	Anaerobic digester		2,896	<u>2,896</u>
	Animal feeding operation			0
	Other			0
Unknown				1,539
Total Direct Response		18,298	2,955	22,792
				<i>Extrapolated Minimum</i>
				25,183
				<i>Extrapolated Maximum</i>
				33,683

^[1] Other was unspecified.

The tons that are not otherwise reported to DEC are extracted from Table 7-5 and shown in Table 7-6. As shown, a total of 4,756 tons are identified as materials going to farm composters, animal feeding operations, and out of state facilities that would not be reported to DEC.

Table 7-6 Tons Not Otherwise Reported to the State

Food Waste Destination	Tons
Out-of-State	2,955
Farm Composter	993
Animal Feeding Operation	807
Other ^[1]	<u>1</u>
Total	4,756

^[1] Other was unspecified.

Figure 7-2 compares the amount of source-separated and packaged food scraps provided by responsive, permitted transporters to be delivered to each outlet. As shown, depackaging facilities receive a significant percentage of all transported food scraps, but source separated food tends to go to composters or animal feeding. Conversely, packaged food goes primarily to depackaging facilities or out-of-state AD facilities. Much of the food scraps that are processed by Vermont ADs first go through the depackaging facility.

7. ORGANICS MANAGEMENT TRANSPORTATION RESEARCH

Figure 7-2 Food Scrap Disposition Reported by Responsive, Permitted Transporters (2022)

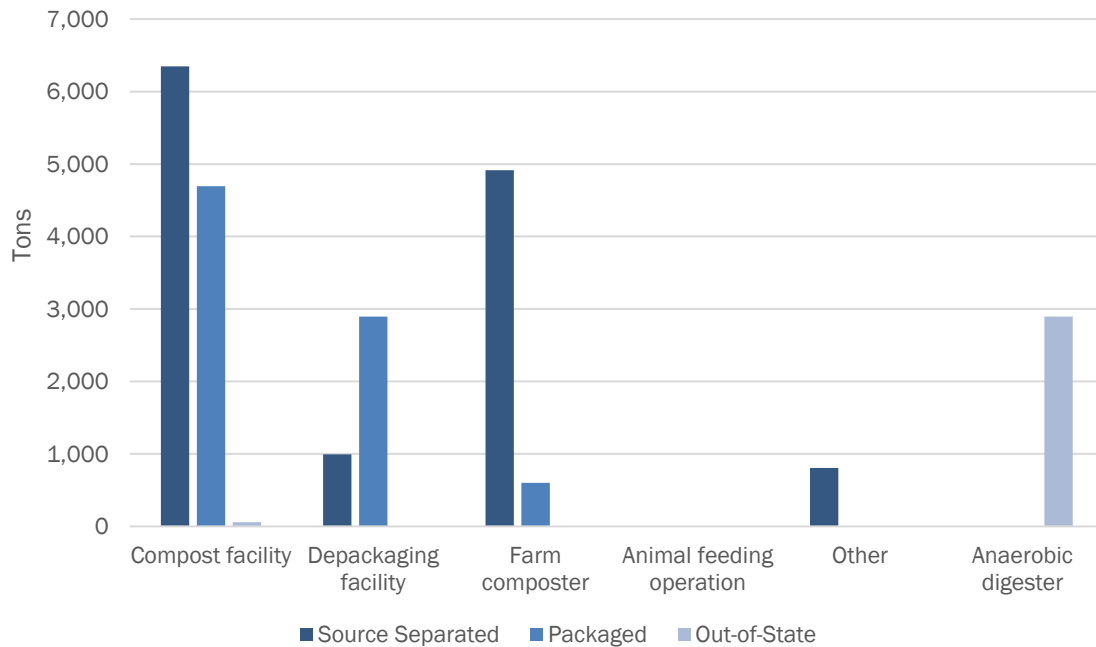

This research confirms that most food scraps are being hauled to reporting facilities. However, it also found 4,756 tons of food scraps being diverted to end uses or processors that do not currently report to DEC.

7.5 LIMITATIONS

The research in this chapter was focused on identifying food scraps that are being diverted outside of reported channels. Solid waste processing facilities in Vermont are required to report their quantities of food scraps processed. Therefore, this chapter focused on two strategies to uncover food scrap diversion outside normal channels:

- Questioning food scrap generators to identify if any are backhauling or self-hauling food scraps, rather than relying on a permitted transporter, and
- Querying food scrap transporters to divulge where they are delivering all collected food scraps, including to facilities or operations outside of certified, reporting solid waste facilities.

While both strategies uncovered previously unreported pathways for food scrap diversion, the Project Team believes that the alternative pathways reported by permitted transporters is the stronger data set. These permitted haulers are accustomed to reporting requirements and are familiar with all outlets for food scraps beyond permitted composting and AD operations. It is believed that their reported tonnage to out-of-state locations, and to animal feed and farming operations, would be reasonably accurate. Further, the extrapolation of responding transporters to the population of non-responsive transporters would appear to provide a reasonable range in which food scrap transporting is occurring.

Conversely, the research into food scraps that are delivered by generators to various pathways outside of the use of permitted transporters is more subject to inaccuracy. First, generators may not have accurate measurement available to them, and may be inaccurately estimating their food waste generation. Second, generators are less knowledgeable about the specific outlets and may have misinterpreted outlets in some cases. Third, the process of identifying and questioning the population of potential generators is more complex and subject to greater uncertainty as a result. It cannot be confirmed that the full universe of

7. ORGANICS MANAGEMENT TRANSPORTATION RESEARCH

generators was identified, nor that the responses were representative of the universe. Nonetheless, the findings of generators and transporters collectively confirm the challenge of measuring organics diversion at the state level.

8. DIRECT-TO-BROKER RECYCLING RESEARCH

8.1 INTRODUCTION

Direct-to-broker, or economically driven recycling, takes place when a business or institution contracts with an end-user directly or through a broker to deliver recyclables generated by the business or institution, bypassing a Vermont materials processing facility. The materials sent directly to market (or to an out-of-state broker or facility) by the generator are not captured by the quarterly and annual reports submitted to the DEC by recycling facilities located in Vermont but can be a significant part of a State's recycling activity. For this reason, many states want to include this activity when measuring their diversion rate.

Vermont first measured direct-to-broker activity in the 2018 Study. This research has again been included in the 2023 Study to provide an update for the 2018 Study. The research methodology and findings are described in this section.

8.2 METHODOLOGY

The methodology of the 2023 Study research intended to follow the 2018 methodology, which included the following steps:

- Developing a questionnaire and introductory verbiage explaining the research and the data being sought, including a statement by the DEC authorizing the project and asking for cooperation.
- Preparing both online and form-based versions of the questionnaire.
- Compiling a list of businesses and institutions that could engage in direct-to-broker recycling, starting with the contact list from the 2018 Study, and expanded by searching the Vermont Department of Labor database and querying DEC staff for trade associations that might serve as distribution agents for the questionnaire.
- Having DEC distribute the initial online questionnaire in hopes that it might go to fewer junk or spam folders than if coming from a consultant or questionnaire-blast email address.
- Engaging the Vermont Retail and Grocers Association (VRGA) to send the online questionnaire link to their membership, which numbers approximately 550 members based on their website.
- Contacting 18 recycling processors, end-users and/or brokers from the 2018 Study to request direct-to-broker activity.
- Systematically following up with all respondents.

Following an initial period targeted as online response deadline, and a subsequent re-issuance by DEC via email, MSW attempted to make direct contact by both telephone and email to secure participation. For a number of larger companies that had not been responsive, MSW submitted online inquiries through their website to request assistance directly from the sustainability or managerial office.

The focus of the questionnaire was to determine which businesses were recycling outside of certified recycling facilities that already report to the state. In the case where the business verified use of a Vermont hauler for all recyclables, the questionnaire was deemed completed. Otherwise, MSW attempted to complete the questionnaire. MSW attempted to contact all the identified businesses at least three times by phone and/or by e-mail.

For the analysis, industry categories were used to classify the business type to better understand recyclable material management trends within each industry sector. Industry categories used were:

- **Retail** - which included big-box stores, department stores, pharmacies, restaurants, and grocers. Retail stores generate significant packaging materials which include corrugated cardboard (OCC), film, plastic, pallets, etc.

8. DIRECT-TO-BROKER RECYCLING RESEARCH

- **Manufacturing and Wholesale** - which includes companies located in Vermont that manufacture or wholesale materials or goods and employ more than 100 people. Companies operating within these industries may generate OCC, paper, film, and plastics, as well as metals and pallets used to transport their materials.
- **Recyclers** - which include companies in and surrounding Vermont that may be involved in brokering materials generated in Vermont and/or processing materials generated in Vermont. These materials would not be transferred through a Vermont transfer station and thus, would likely not be included in any recyclers report to the State. Recyclers primarily reported OCC, paper, and pallets.
- **Institutions** - represent universities, medical facilities or any other institutions located within Vermont and that employ more than 250 people. Institutions frequently use Vermont recycling facilities but may have unique materials that may need to be recycled outside of the traditional recycling stream.

The questionnaire was open-ended in identifying materials being recycled direct-to-broker or to other end markets. Table 8-1 lists the materials identified in the questionnaire as being recycled directly, rather than through registered recycling haulers.

Table 8-1 Materials Identified in the Direct-to-Broker Questionnaire

Cardboard	Electronics
Other Paper	Batteries & Bulbs
Metal, Glass, Plastic	Automotive Batteries
Plastic Film	Tires
Scrap Metal	Pallets

It should be noted that no respondents identified fats/oil/grease (FOG) in response to the 2023 questionnaire. However, DEC and the Project Team are aware of a robust network of generators and haulers that collect and recycle/recover this material such as: Baker Commodities, Black Bear Biodiesel, and Wind River Environmental. Recycling activity associated with these materials was included in the 2018 Study but was largely or even entirely estimated. Additionally, when other materials than those in the table above were reported as recycled, they were aggregated into the “Other” category. Finally, metals typically found in construction waste or from automobiles, other vehicles, or transportation-related materials (such as oil and lead-acid batteries) were excluded from the research because they fall outside of the municipal solid waste stream.

Note that the Project team focused on the direct responses provided by the targeted companies. In 10 cases, we received a response from one or more locations of a company doing business in Vermont, but not for all locations. In such instances, we used the reported location data as a basis to estimate tonnage from the other non-reporting locations in Vermont. Additional steps taken to provide perspective on the potential data gap arising from non-responsive entities are described later in this section.

8.3 RESPONSE RATES

Table 8-2 shows the breakdown of respondents by response type and industry category. As shown, after adjusting for entities on the original contact list that were found to have gone out of business, or who declined outright to participate, there were 472 entities eligible to respond, out of which 198 (42 percent) responded.

8. DIRECT-TO-BROKER RECYCLING RESEARCH

Table 8-2 Direct-to-Broker Questionnaire Summary

Outreach Outcome	Retail	Manufacturing and Wholesale	Recyclers	Institutions	Total Locations
Completed Questionnaire – YES	169	14	15	18	198
Business Closed/Participation Declined	32	14	1	1	48
Multiple Attempts Made/No Response Received	202	39	4	11	256
Total Outreach Population	403	67	20	30	520
<i>Total Outreach minus Closed/Declined</i>	371	53	19	29	472
<i>Response Rate</i>	45.5%	26.4%	78.9%	62.1%	45.8%

8.4 QUESTIONNAIRE RESULTS

There were two primary outcomes for direct-to-broker communications. First, when an entity indicated that they did not back-haul any material or send any material directly to a broker or end market, but rather used a recycling hauler, the questionnaire was concluded because the tonnage of recyclables from these entities would be captured in recycler reports. Table 8-3 shows the breakdown of respondents that reported using a recycling hauler for all recycled materials. As shown, most of the respondents reported the use of a recycling hauler.

Table 8-3 Percentage of Respondents Using Recycling Haulers

Industry	Respondents Using DTB	Respondents Using a Hauler	Percent of Respondents Using a Hauler
Retail	26	143	84.6%
Manufacturing and Wholesale	1	13	92.9%
Recyclers	4	11	73.3%
Institutions	0	18	100.0%
Total	31	185	85.6%

Table 8-4 summarizes the tonnage of material provided by the 31 responsive entities in the previous table (down from 52 respondents with backhaul in the 2018 study). These entities reported the use of backhaul of some material and/or direct delivery of certain materials to an end user. As shown, these entities reported over 12,670 tons of economically driven recycling.

Table 8-4 Verified 2023 Direct-to-Broker Tonnage

Industry	Retail	Industry/Wholesaler	Recycler	Institution	Total
Cardboard	7,868	81	966	0	8,914
Other Paper	5	128	400	0	533
Metal, Glass, Plastic	8	5	0	0	13
Plastic Film	226	0	0	0	226
Scrap Metal	3	0	0	0	3
Pallets	0	0	2,848	0	2,848
Other	134	0	0	0	134
Total Tons	8,244	213	4,214	0	12,671

8. DIRECT-TO-BROKER RECYCLING RESEARCH

It is apparent that the 2023 questionnaire responses did not provide the level of detail by various material categories as was obtained in the 2018 Study. The questionnaire was designed with online submittal capabilities with questions similar to the ones used in 2018 including specifically identified categories along with fill-in options if respondents diverted other materials. The Project Team notes variations in the workforce (staffing turnover and shortages) that have heightened since 2018 (particularly post-Covid 19 pandemic) that may have influenced management's time availability to complete the questionnaires. Further, the Project Team encountered numerous automated answering systems that led to dead ends, and sensitivity by private sector organizations over the provision of data to state and local governments (even with the promise of confidentiality), both which may have impacted responsiveness. The Project Team made an attempt to map 2023 questionnaire responses to the 2018 material category lists for purposes of comparison.

Several observations are offered about the preceding tables. First and foremost, the tonnage confirmed directly by respondents in 2023 was significantly lower than the 2018 reported tonnages. This was especially true for paper packaging (which includes corrugated cardboard and printing paper).

Second, many entities that have historically backhauled and sold recyclables direct to brokers reported using recycling haulers in the 2023 survey. Unfortunately, due to confidentiality assurances to respondents, no detailed response data can be provided for public review. However, the Project Team believes that Casella has obtained an increasing share of the brokerage business, which supports the likelihood that incrementally more recyclables are now being collected by a reporting entity. Presumably Casella, as a reporting recycler, would be providing a higher tonnage since 2018, although DEC indicated that this was not the case.

As a result of these shortfalls in tonnage in comparison to 2018, the Project Team reviewed and compared 2018 and 2023 responses, and used responses from 2018 to gain perspective on the potential data gaps from nonrespondents to the 2023 questionnaire. Note that the Project Team is not claiming that all the unresponsive entities in 2023 that responded to the 2018 questionnaire are behaving identically five years later, nor are we attempting to extrapolate 2023 outcomes from the 2018 responses. However, the Project Team believes it is informative to have such perspective from the 2018 data set because there is a wider gap in the 2023 responses.

Table 8-5 tabulates the additional tons that were reported in 2018 and were found by responses in 2023 to be collected by a third-party hauler. This finding further suggests that the broker industry is losing some material to conventional recycling haulers, as almost 4,900 tons from this subset of entities was reported to be recycling directly in 2018.

Table 8-5 Reported 2018 Direct-to-Broker Tonnage Now Collected by Third-party Haulers

Material	Manufacturing/			Institutions	Total
	Retail	Wholesale	Recyclers		
Cardboard	2,555	20	80	0	2,655
Other Paper	2	2	600	0	603
Metal, Glass, Plastic	628	0	0	0	628
Plastic Film	24	7	0	0	31
Scrap Metal	265	0	0	62	327
Pallets	65	0	0	0	65
Other	0	0	565	0	565
Total Tons	3,538	29	1,245	62	4,874

8. DIRECT-TO-BROKER RECYCLING RESEARCH

As an additional exercise, Table 8-6 identifies the tons that were reported in 2018 by businesses who did not complete a questionnaire in 2023. As shown, if these businesses were behaving identically in 2023, and had responded to the research, there would have been an additional 10,335 tons of economically driven recycling reported in 2023. Again, we are not asserting that this total should be added to 2023 results; only that it sheds light on the tonnage difference in the 2023 research update.

Table 8-6 2018 Direct to Broker Tonnage from Unresponsive Businesses in 2023

Industry	Retail	Industry/ Wholesaler	Recycler	Institution	Total
Cardboard	1,562	892	1,519	0	3,973
Other Paper	61	2,250	167	0	2,478
Meal, Glass, Plastic	31	110	0	0	142
Film	80	96	0	0	176
Scrap	72	833	234	91	1,231
Pallets	2,044	17	0	0	2,061
Other	169	97	1	7	274
Total Tons	4,020	4,296	1,921	98	10,335

However, it should be noted that roughly 20 percent of the businesses who reported economically driven recycling in 2018 have updated in 2023 that their material is now being collected by a hauler. The breadth of the companies converting from direct-to-broker to conventional recycling hauler spans multiple types of businesses and industries. For this reason, the Project Team believes it is appropriate to reduce the 2018 “maximum DTB” tonnage by 20 percent. This adjustment is shown in Table 8-7. The result suggests that an upper boundary for direct to broker recycling in 2023 could be as much as 8,268 more tons of recyclables when incorporating estimates for unresponsive businesses. The actual amount cannot be readily estimated.

Table 8-7 Adjusted Direct to Broker Tonnage from Unresponsive Businesses in 2023

Industry	Retail	Industry/ Wholesaler	Recycler	Institution	Total
Cardboard	1,250	714	1,215	0	3,179
Other Paper	49	1,800	134	0	1,982
Metal, Glass, Plastic	25	88	0	0	114
Film	64	77	0	0	141
Scrap	58	667	187	73	985
Pallets	1,635	14	0	0	1,649
Other	135	78	1	6	219
Total Tons	3,216	3,437	1,537	79	8,268

To compare the 2023 research results with the 2018 research, Figure 8-1 places the derived tonnage side by side. 2023 tonnage includes both directly-provided materials (Table 8-4) and the extrapolated additional material that could be getting recycled if unresponsive businesses in 2023 continue to backhaul as in 2018 (based on the adjusted tons in Table 8-7). Assuming the businesses that responded to the survey are representative of Vermont businesses that engage in direct-to-broker recycling, this combined tonnage likely provides a reasonable estimate of recycling that occurs by Vermont businesses, but outside of Vermont’s regulated recycling facilities.

8. DIRECT-TO-BROKER RECYCLING RESEARCH

Figure 8-1 Direct-to-Broker Material Quantities, 2023 and 2018 Reports

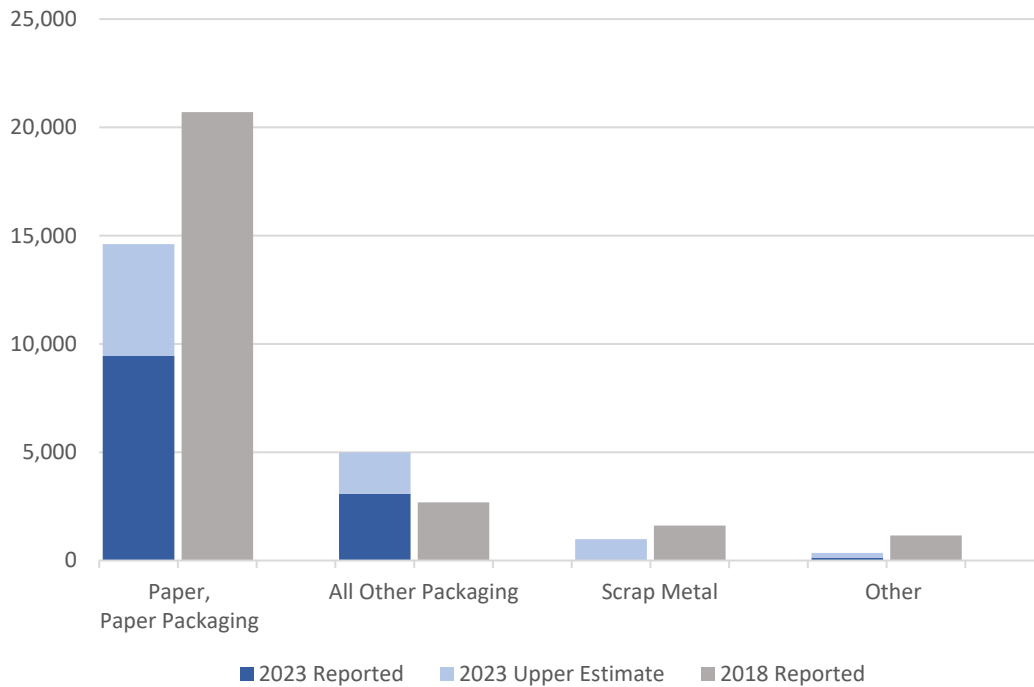

While the objectives of the 2018 and 2023 studies were the same, the underlying questionnaire protocol and response rates diverged enough to cloud the ability for comparison. However, the data suggests that at least some recyclable material that was being back-hauled or sent directly to broker in 2018 has shifted to registered recycling haulers in 2023, thereby reducing the quantity of economically-driven recycling.

8.5 LIMITATIONS

Ultimately the Project Team feels that a reasonable figure for representing estimated Direct-to-Broker recycling in Vermont is approximately 20,939 tons per year (12,670 tons per year from verified respondents (Table 8-4) plus 8,268 tons extrapolated from non-respondents (Table 8-7)).

The Project Team’s methodology for estimating economic recycling only counts material reported to be recycled and does not make per capita, per employee, or other estimates based on recycling coefficients except in the case where a specific large retailer, wholesaler or recycler did not report for a location and MSW Consultants (hereinafter “MSW”) was able to use estimates from other locations. This methodology is more likely to under-report than over-report economic recycling activity since some generators and brokers have likely not been identified or have not responded to the research inquiry.

Because reporting is not mandatory, MSW relied on voluntary participation. Data from some companies that did not participate may impact actual economic recycling figures. Despite MSW’s best efforts to gain participation, some companies reported that they have a policy to only participate in questionnaires when it is mandatory. And some companies that did participate do not track their recycling data (as they have no reason to do so) and the team relied heavily on their own estimates to provide tonnage data.¹

¹ It was the MSW’s experience that the communication-intensive research needed to complete the direct-to-broker research task has become more difficult since 2018. Some companies explicitly declined to participate in voluntary disclosure research as a matter of corporate policy. Others could not be reached or persuaded to return a phone call or email even

8. DIRECT-TO-BROKER RECYCLING RESEARCH

The final estimates made by MSW are only as good as the data provided. MSW focused heavily on information provided by large retailers as they are geographically widespread and generally have the highest economic recycling generation activity. However, even our repeated email and telephonic requests to respond did not convince some larger retailers to participate. MSW assumes that the retailer recycling activity responses are accurate for the State of Vermont. Additionally, MSW relied on all reporters to accurately identify the end-user or processor for their materials to avoid double counting of these materials.²

Finally, scrap metal recyclers were not included in the direct research of economically driven recycling. Large volumes of scrap metal are recycled and transported to scrap metal recyclers in non-permitted vehicles, with little to no reporting in place. Therefore, as is the case in all states, it is extremely difficult to accurately track scrap metal recycling and follow the definitions for municipal solid waste recycling which tracks only metal packaging and durables, including appliances. Without (i) a customized research protocol of, and (ii) mandated participation by the scrap metal recycling facilities in Vermont detailing the types of scrap metal they handle, scrap metal recycling from the institutional, commercial, and industrial sector is impossible to accurately track.

after multiple attempts. Even when reaching the appropriate internal contact, sometimes there were insufficient records available to provide tonnage, which led to estimation by the Project Team.

² Although there may be practical obstacles, in the future the State may wish to consider requiring large generators, brokers, and end markets to report economically driven recycling, including backhaul and export activities. Such reporting would ideally create a level field of expectations within the business community and eliminate the need for this directed research in the future. Mandated reporting could be modeled after the State of Delaware requirements.

8. DIRECT-TO-BROKER RECYCLING RESEARCH

This page is intentionally left blank.

APPENDIX A

2023 Waste Composition Study Design

This page intentionally left blank.

**State of Vermont
Department of Environmental
Conservation**

2023 Waste Composition Study

FINAL STUDY DESIGN

Revision March 2024



MSW CONSULTANTS

11875 High Tech Avenue, Suite 150, Orlando, FL | (800) 679-9220
www.mswconsultants.com



This report was delivered electronically. If it is necessary to print hard copies, please do so on post-consumer recycled paper and recycle.

TABLE OF CONTENTS

1. INTRODUCTION.....	1
1.1 Roles & Responsibilities.....	1
2. WASTE GENERATION	2
3. STUDY DESIGN	4
3.1 Waste Sectors.....	4
3.2 Seasonality	4
3.3 Logistical Coordination.....	5
3.4 Sample Weights	5
3.5 Sample Targets	5
3.6 Material Categories – Manual Sorts.....	6
3.7 Material Categories – Visual Surveys.....	9
3.8 Data Collection Methods	10
3.9 Safety & Health	10
4. GATE SURVEY.....	11
4.1 Gate Survey Plan.....	11
5. FIELD DATA COLLECTION PROCEDURES.....	12
5.1 General Space Requirements.....	12
5.2 Load Selection	13
5.3 Sample Acquisition	13
5.3.1 MSW Samples Selection: Grab Sampling	13
5.3.2 MRF Residue Pre-Sort & Residue Samples.....	14
5.4 Manual Sorting	14
5.5 Visual Surveying.....	14
5.6 Data Recording.....	16
5.7 Site Maintenance & Clean-up.....	17
6. ANALYSIS	18
7. REPORTING	18
7.1 Problem Identification Reporting.....	18
7.2 Interim Reporting	18
7.3 Final Report Progression	19

TABLE OF CONTENTS

LIST OF APPENDICES

Appendix A – Material Categories and Definitions

Appendix B – Safety and Health Plan

List of Figures

Figure 2-1 Map of Disposal & Recycling Facilities Targeted for Study	3
Figure 4-1 Screenshot of Gate Survey Questionnaire	12
Figure 5-1 Systematic Sampling Guide for Tipped Loads.....	13
Figure 5-2 Manual Sorting.....	14
Figure 5-3 Visual Survey of a C&D Loads.....	15
Figure 5-4 Visual Surveying App Interface (screenshot)	16
Figure 5-5 Waste Sort Data Entry Screenshot	17

List of Tables

Table 2-1 Vermont Waste Disposal (2021).....	3
Table 3-1 Tentative Sampling Schedule	4
Table 3-2 Sampling Plan for MSW Hand Sorts	5
Table 3-3 Sampling Plan for C&D/Bulky Visual Surveys.....	6
Table 3-4 Sampling Plan for MRF Residual Sorts	6
Table 3-5 Material Categories & Divertibility Classes – MSW Hand Sort.....	8
Table 3-6 Material Categories & Divertibility Classes – MRF Residue Hand Sort.....	9
Table 3-7 Material Categories & Divertibility Classes – C&D/Bulk Visual Survey	10
Table 4-1 Anticipated Gate Survey Days	11

VERMONT 2023 WCS STUDY DESIGN

1. INTRODUCTION

The State of Vermont has contracted MSW Consultants to complete a waste characterization study (WCS) of municipal solid waste within the state. Vermont last completed a statewide characterization study in 2018 (2018 Study). Since that time, updates to the state's Universal Recycling Law and Single-Use Products Law have fully banned the disposal of food scraps from the trash and set limitations on commercial and retail use of single-use plastic bags, Styrofoam food and beverage containers, plastic straws, and other single-use items. State and local governments have also increased public outreach and education efforts to increase diversion and reduce landfill waste.

The 2023 WCS will provide an update to the 2018 Study while also providing new elements in the form of residual materials characterization at two representative Materials Recovery Facilities (MRFs), expanded visual surveys of construction and demolition (C&D) waste, and desktop surveys (under separate cover) of residential food scraps, direct to broker recycling, and the organics management transportation system. The characterization of commercial and residential wastes, MRF residuals, and C&D visual surveys will be carried out over two seasons during the 2023 calendar year, with waste characterization activities occurring at two permitted solid waste facilities in early summer and two other permitted solid waste facilities in the fall. Locations for the sorting of MRF residuals and C&D visual surveys will be finalized with Vermont DEC support.

Consistent with the 2018 Study, this study will incorporate the following elements:

- ◆ **Gate Surveys** – Working with the DEC to finalize the targeted facility list, waste facilities across the state will be recruited based on several criteria including DEC input and volume throughput, and potentially other factors. The information gathered during the gate surveys will provide a basis for estimation of residential vs. industrial/commercial/institutional (ICI) waste generation.
- ◆ **MSW Characterization** – to characterize the composition of generated municipal solid waste destined for landfill or waste-to-energy facilities.
- ◆ **C&D/Bulky Characterization** – to characterize the material stream of construction, demolition, and bulky loads not typically captured by the MSW sorts.

New to the 2023 Study is a **MRF Residuals Characterization** which will identify material types and amounts destined for landfill or waste-to-energy facilities following recyclables processing.

Other project tasks not addressed in this document that will be planned and performed separately include:

- ◆ Direct to Broker/Economic recycling survey,
- ◆ Residential Food Scrap Management survey, and
- ◆ Organics Management Transportation survey.

The results of these surveys will be included in the final project report.

1.1 ROLES & RESPONSIBILITIES

Emma Stuhl, Environmental Analyst, Vermont DEC, will serve as the Project Manager and primary contact for the Project Team during the implementation of the study. MSW Consultants is in collaboration with the DEC in finalizing the solid waste disposal facilities that will host the various components of field data collection.

STUDY DESIGN

MSW Consultants' professional consulting staff have redundant waste characterization management, field supervisory experience, operations, and analytical experience. The MSW Team below will support this project (and MSW Consultants employs additional staff beyond those shown below who have similar experience). Their roles are listed:

- ◆ **John Culbertson**, Principal, MSW Consultants (Technical Oversight of Sampling Plan and Statistical Analysis, Project Resource Optimization)
- ◆ **Ted Siegler**, Principal, DSM Environmental Services (Technical Advisor)
- ◆ **Cynthia Mormile**, Senior Project Manager, MSW Consultants (Project Lead, C&D Visual Survey Specialist)
- ◆ **Joe Vetrano, LEED AP**, Senior Consultant, MSW Consultants (Waste Characterization Task Lead and Supervisor, sort crew training)
- ◆ **Natalee Mannion**, Project Manager, MSW Consultants (Crew Chief, sort crew training)
- ◆ **Shelly Wilson**, Waste Characterization Specialist, MSW Consultants (Crew Chief, sort crew training)
- ◆ **Charles Wilson**, Waste Characterization Specialist, MSW Consultants, (Waste Characterization, sort crew training)

The following roles will be implemented during field data collection:

The **Project Lead** will be responsible for project management of day-to-day project operations and will be in contact with Vermont DEC as needed.

The **Field Supervisor** will initiate the sampling process each day using the agreed upon approach. He will arrive at the facility early in the morning to contact facility scale house personnel, the loader operator, or other designated personnel. He will also be the designated person to check in and check out with the scale house each day. He will be in charge of tracking samples that need to be collected that day and will assist as needed in the visual surveys of C&D loads. Lastly, he will administer the Health and Safety Plan. The DEC Project Manager shall be notified of any changes to the Field Supervisor position.

The **Crew Chief** will manage the sorting function at each host facility and verifying and recording sample data. She will oversee weighing out all the materials after each sample has been sorted. Lastly, she will make sure the sorting crew adheres to the Health and Safety Plan. The Crew Chief will be the primary sort team trainer on characterization techniques, material category definitions, and will cover all aspects of safety and health requirements at the beginning of each season. The Crew Chief will also manage the sorting crew throughout the project.

The **Visual Surveyor** will perform visual volumetric surveys at each of the facilities hosting the (non-MSW) construction and demolition composition analysis. This individual will be responsible for coordinating with the scalehouse to align gate survey data with inbound load data and will need to work collaboratively with a spotter and loader operator on the tip face/tipping floor during the visual volumetric surveys of tipped loads of non-MSW.

The **Gate Surveyor** will be a professional staff team member trained to evaluate inbound loads by truck type, generator type, origin, and other information.

2. WASTE GENERATION

Table 2-1 below lists the most recently reported tonnage disposed in the State of Vermont. MSW data is presented as mixed waste, as transfer stations do not necessarily separate C&D materials from MSW before it is sent to the landfill.

Table 2-1 Vermont Waste Disposal (2021)

Waste Type	Tons	Percent
Mixed MSW (may include residential & commercial refuse & C&D)	401,509	91.8%
C&D Waste Only	21,584	2.8%
Recyclables Processing Waste (100% Transported from Out of State)	23,465	5.4%
Totals	446,558	100.0%

Materials are managed throughout the state by numerous drop-off centers, food scrap management facilities, and transfer stations, along with two large and several smaller Materials Recovery Facilities, two Architectural Materials Recycling facilities, and one Sanitary Landfill. Figure 2-1 identifies the facilities that are planned for sampling activities for the 2023 study.

Figure 2-1 Map of Disposal & Recycling Facilities Targeted for Study

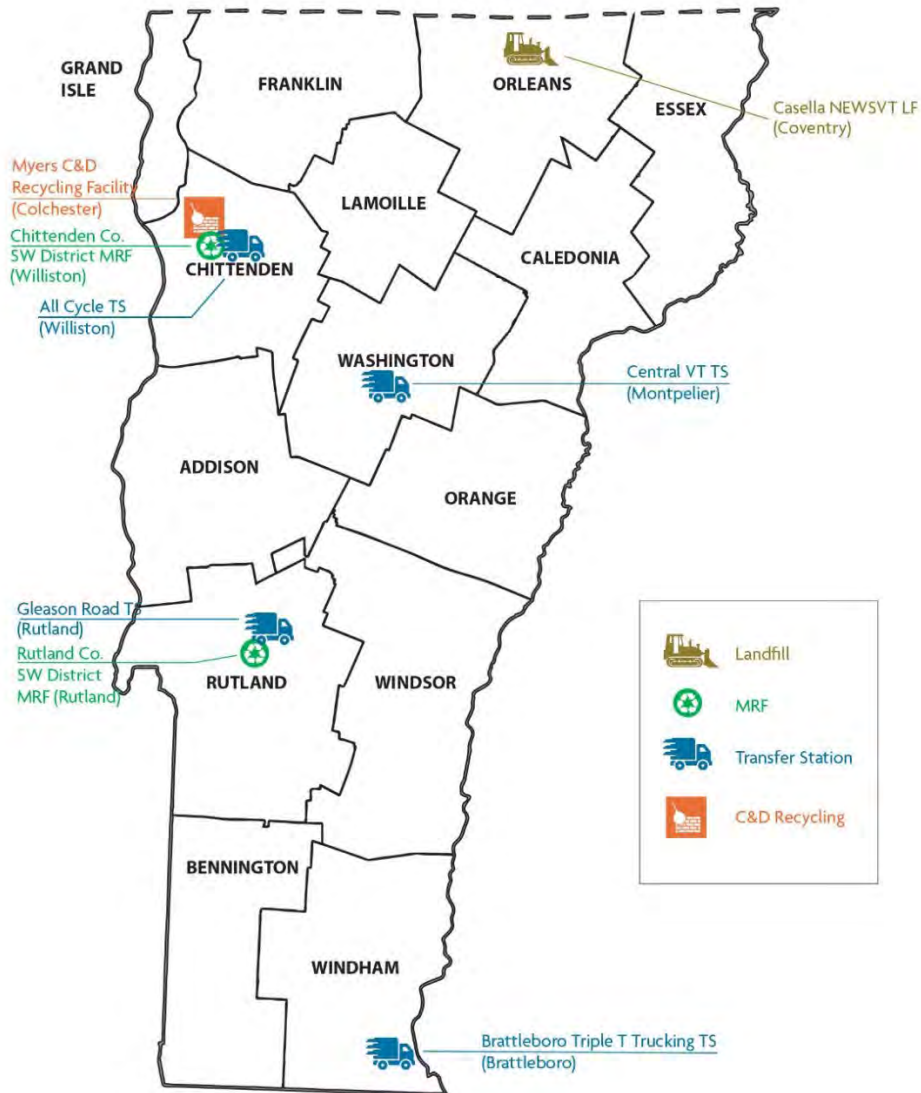

STUDY DESIGN

3. STUDY DESIGN

3.1 WASTE SECTORS

Consistent with the 2018 Study, the intent will be to identify sampled loads of MSW or surveyed loads of C&D materials as being generated by sectors, shown below.

- ◆ **Residential** – defined as waste brought to VTDEC permitted facilities by commercially or municipally operated vehicles, in which 80% or more of the waste is from single-family and/or multifamily residential sources. This includes public housing, condominium complexes, or apartments. Vehicles chosen for sampling in the Residential waste sector will primarily include packer trucks but may also include roll-off containers from residential drop-off locations if they are believed to contain at least 80% waste from residential sources.
- ◆ **Institutional/Commercial/Industrial (ICI)** – defined as waste brought to VTDEC permitted facilities by commercially operated vehicles, in which 80% or more of the waste is from institutional, commercial, or industrial sources. Such facilities include businesses, hospitals, schools, manufacturing facilities, and allocated to industry groups organized according to appropriate NAICS codes. This sector excludes Construction and Demolition debris as well as Bulky Waste. Vehicles chosen for sampling in the ICI sector will likely include packer trucks and roll-off compactors.
- ◆ **Unacceptable Loads** – Loads that contain less than 80% of either residential or ICI waste, and loads originating from outside of Vermont, will be omitted from sample selection. Note that in some cases where the majority of loads entering a facility are mixed residential and commercial and it is impossible to obtain a sufficient number of samples of residential or ICI loads from trucks with over 80% of the designated material, a decision can be made by the Field Supervisor, after discussions with the truck driver, to sample from the portion of the load which the driver indicates is primarily residential or ICI waste.
- ◆ **C&D Loads** – Loads that contain 80% or more of material generated from construction and demolition activities. It may also include “dry waste loads” which are primarily bulky waste loads managed as C&D loads.

3.2 SEASONALITY

Field data collection will be performed over two seasons. A “Spring” season has been tentatively scheduled for June and a “Fall” season is anticipated to occur at some point in September as shown in Table 3-1. Both seasons will be coordinated and confirmed with the facilities and state staff.

Table 3-1 Tentative Sampling Schedule

Project Phase	Facility	Season 1	Season 2
Gate Surveys	All-Cycle Transfer Station, Williston	June	N/A
	Casella NEWSVT Landfill, Coventry	June	
	Central VT Transfer Station, Montpelier	June	
	Gleason Road Transfer Station, Rutland	June	
Hand Sorts - Refuse	All-Cycle Transfer Station, Williston	June	September
	Brattleboro Transfer Station, Brattleboro		
	Casella NEWSVT Landfill, Coventry	June	
	Gleason Road Transfer Station, Rutland		
Hand Sorts - MRF Residuals	Rutland County SWD MRF, Rutland		September
	Chittenden County SWD MRF, Williston		September
C&D Visuals	Myers C&D Recycling Facility, Colchester	June	September
	Casella NEWSVT Landfill, Coventry	June	September

3.3 LOGISTICAL COORDINATION

A critical component to the success of on-site operations consists of all the advance arrangements required for Project Team personnel to execute the field data collection portion of this project safely and efficiently. Once the locations are approved by DEC, MSW Consultants will reach out to each facility to discuss logistics, such as:

- ◆ Confirming procedures requiring coordination between the host facility personnel and the Project Team.
- ◆ Information about available space for sampling and sorting crews and the availability of operational resources, such as a loader.
- ◆ Information on vehicle traffic (by time of day) including delivery patterns, and numbers of vehicles arriving, by vehicle type and/or by waste subsector.
- ◆ Finalizing locations for setting up the work area, taking samples, queuing samples, discarding sorted samples, and other in-process activities.
- ◆ For MRFs, information about the mix of inbound materials, the commodities sorted, and the various ejection points where residuals are generated (typically the pre-sort stations and one or more end-of-line residue ejection points).
- ◆ Answering any questions and addressing the concerns of the Facility Managers.
- ◆ MSW Consultants will provide all sorting equipment (table, bins, carry cans, scales, small tools, and personal protective equipment) needed for the project. In some cases, coordination with Facility Managers is required to advise of any additional PPE required at specific locations.

3.4 SAMPLE WEIGHTS

Consistent with industry standards (ASTM D 5231-92 (2016)) and the 2018 study, 200-to-250-pound samples will be the targeted sample weight for the MSW hand sorts. MRF Residue hand sorts samples vary depending on the residue type, as shown in the Sampling Plan Table 3-4. The Project Team’s sampling expertise will ensure that representative and random samples meeting desired weight targets will be acquired consistently throughout the project.

C&D visual samples will involve a volumetric assessment of the entire tipped load.

3.5 SAMPLE TARGETS

Remaining consistent with the 2018 study for MSW and C&D/Bulky loads, tables outlining the sample plan for MSW and C&D/Bulky waste are provided below in Table 3-2 and Table 3-3.

Table 3-2 Sampling Plan for MSW Hand Sorts

Facility	Residential Samples	ICI Samples	Total MSW Samples
Season 1			
All-Cycle Transfer Station, Williston	22	23	45
Casella NEWSVT Landfill, Coventry	23	22	45
Season 2			
Gleason Road Transfer Station, Rutland	23	22	45
Brattleboro Transfer Station, Brattleboro	22	23	45
Total	90	90	180

STUDY DESIGN

Table 3-3 Sampling Plan for C&D/Bulky Visual Surveys

Facility	Proposed 2023 Season 1 Surveys	Proposed 2023 Season 2 Surveys	Total
Casella NEWSVT Landfill, Coventry	15-25	15-25	30-50
Myers C&D Recycling Facility, Colchester	15-25	15-25	30-50
Total	30-50	30-50	60-100

Note: Sample ranges are dependent on loads arriving at the facilities. It is also possible that Gate Survey or MSW Hand Sort professional staff may be able to conduct some C&D Visual samples while at other sites.

New to the 2023 study is the MRF Residue sort sampling plan. The final sampling and surveying plans will be determined with input from the state, but MSW Consultants anticipates a sampling strategy similar to that shown in Table 3-4. This approach provides the best opportunity to identify where the residuals are coming from within the system as well as what materials make up the residue.

Table 3-4 Sampling Plan for MRF Residual Sorts

Residue Type	Notes on Material Origin	Sample Size/Weight	No. of Samples per Facility	Total Samples
Pre-sort Line	Positive sort of oversize reject materials	100-200 lbs.	12-15	24-30
End-of-line Residues	Negative sort	50-100 lbs.	12-15	24-30
Glass Residue	Negative sort	2-gal to 5-gal bucket	5-8	10-16
Other Residues	Misc locations	Varies, probably <50 lbs.	0-8	0-16
Total			29-46	58-92

3.6 MATERIAL CATEGORIES – MANUAL SORTS

The material category list for the MSW manual sort was provided by DEC in the RFP with slight changes since the 2018 study and refined through discussions with DEC as shown in Table 3-5. The full list of categories and definitions is provided in Appendix A. Note that each material category list identifies each material with respect to its divertibility in the state.

◆ MSW Material Categories and Divertibility Classes:

- ◆ **Mandated Recyclable:** items banned from the trash and acceptable for placement in the area’s “blue bin” recycling collection program. (Note: this excludes #5 polypropylene (PP) plastic containers which are not banned from trash but are widely recycled in Vermont).
- ◆ **Mandated Organic:** items that are banned from trash like food waste, leaf and yard debris, and clean wood and generally accepted in composting programs throughout the state.
- ◆ **Potentially Divertible:** items that are not mandated, although may be accepted in the local “blue bin” recycling or organics collection programs or may be taken to specific outlets for recycling or reuse. Diversion options may only exist in specific regions in Vermont.
- ◆ **Non-Divertible:** all remaining materials that are not currently collected in the recycling and organics programs and do not otherwise have a local diversion outlet.

Several of the MSW categories will also be further defined with respect to the state’s container deposit bill, noted on the material category lists as:

- ◆ **BB – Bottle Bill** – when purchased in VT: beer, wine coolers, other malt beverages, and pre-mixed spirit cocktails; carbonated non-alcoholic beverages, including sodas, sparkling waters and juices, and carbonated sports and energy drinks; and liquor and spirits.

- ◆ **EBB – Expanded Bottle Bill** – to include water bottles, energy drinks, wine, alcoholic hard cider, and juices.
- ◆ **NBB – Non-Bottle Bill** – includes dairy products, plant-based beverages, infant formula, meal replacement drinks, non-alcoholic cider; beverages purchased out of state.

STUDY DESIGN

Table 3-5 Material Categories & Divertibility Classes – MSW Hand Sort

Material Category	Material Category
Paper	Organics
1 OCC & Kraft Paper	32 Food Waste - Contained in Packaging
2 Boxboard (Chipboard)	33 Food Waste - Unpackaged
3 Newsprint	34 Branches & Stumps >1"
4 Mixed Recyclable Paper	35 Leaves, Grass, & Brush <1"
5 Magazines/Catalogs	36 Wood - Clean
6 High Grade Office Paper	37 Pet Waste
7 Polycoated/Aseptic Containers	38 Other Organics
8 Books	Electronics
9 Compostable Paper	39 Banned - Non-CED Electronics
10 Remainder/Composite Paper	40 CEDs - CRTs
Plastic	41 CEDs - Computer Peripherals
11 #1 PET Bottles	42 CEDs - Desktop Computers
a #1 PET Bottles - BB	43 CEDs - Laptops/Tablets
b #1 PET Bottles - EBB	44 CEDs - Printers
c #1 PET Bottles & Jars - NBB	45 CEDs - Television/Monitors (Non-CRT)
12 #2 HDPE Bottles	46 Products with Embedded Batteries
a #2 HDPE Bottles - BB	47 Small Appliances
b #2 HDPE Bottles - EBB	48 White Goods
c #2 HDPE Bottles & Jars - NBB	Household Hazardous Waste
13 #3 - #7 Bottles	49 Batteries - Lead Acid
a #3 - #7 Bottles - BB	50 Batteries - Primary
b #3 - #7 Bottles - EBB	51 Batteries (Rechargeable)
c #3 - #7 Bottles & Jars- NBB	52 Mercury Containing Products - Lamps
14 #5 PP Food Containers	53 Mercury Containing Products - Thermostats
15 #6 PS Rigid Food/Beverage Containers	54 Mercury Containing Products- Other
16 #6 EPS Food/Beverage Containers	55 Paint
17 Bulky Rigid Plastics > 1 Gallon	56 Other HHW
18 Plastic Thermoforms	Construction & Demolition
19 Film - Agriculture & Marine Shrink Wrap	57 Asphalt, Brick and Concrete (ABC)
20 Film - Retail Bags	58 Asphalt Shingles
21 Film - Garbage Bags	59 C&D Metal
22 Film - Other Bags	60 Drywall/Gypsum Board
23 Film - Other - Non-Bag	61 Oriented Strand Board
24 Remainder/Composite Plastic	62 Other/Residual C&D
Metal	63 Wood - Painted and Treated
25 Aluminum Beverage Cans	64 Plywood
a Aluminum Beverage Cans - BB	65 Carpet & Carpet Padding
b Aluminum Beverage Cans - EBB	Special/Other
26 Aluminum Foil, Pans, and Non-Bottles	66 Diapers/Sanitary Products
27 Ferrous Containers	67 Fines/Dirt/Mixed Residue
28 Other Ferrous	68 Furniture/Bulky Items
29 Other Non-Ferrous	69 Rubber
Glass	70 Textiles and Leather
30 Glass Beverage Bottles	71 Tires
a Glass Beverage Bottles - BB	All Other Waste
b Glass Beverage Bottles - EBB	72 All Other Wastes Not Elsewhere Categorized
c Glass Beverage Bottles - NBB	
31 Other Glass	
<i>1-10 Mandated Recyclable</i>	
<i>32-35 Mandated Organic</i>	
<i>7-10, 37-38 Non-Divertible</i>	
<i>11-31, 39-72 Potentially Divertible through Special Statewide or Regional Recycling Collections</i>	

- ◆ **MRF Residue Material Categories:** A smaller, more targeted subset of material categories was used for the MRF residue sorts. These categories and divertibility class are shown in Table 3-6, with detailed definitions contained in Appendix A.

Table 3-6 Material Categories & Divertibility Classes – MRF Residue Hand Sort

Material Category									
Paper									
1	OCC								
2	Boxboard (chipboard)								
3	Mixed Recyclable Paper								
4	Polycoated/Aseptic Containers								
5	Compostable Paper								
6	Remainder/Composite Paper								
Plastic									
7	#1 PET Bottles & Jars								
8	#1 PET Other Containers								
9	#2 HDPE Bottles & Jars								
10	#2 HDPE Other Containers								
11	#3 PVC								
12	#5 PP Bottles & Jars								
13	#5 PP Other Containers								
14	#6 Expanded Polystyrene (EPS)								
15	Bulky Plastic								
16	Film Plastic								
17	Other Rigid Plastic								
Glass									
18	Glass Bottles & Jars								
Metal									
19	Aluminum Beverage Cans								
20	Aluminum Foil, Pans, and Containers								
21	Ferrous Containers								
22	Other Ferrous								
23	Other Non-Ferrous								
Organics									
24	Food Waste								
Household Hazardous Waste									
25	Batteries								
26	Other HHW								
Other Waste									
27	All Other Wastes Not Elsewhere Categorized								
28	2-Inch Minus Materials								
29	Bagged Materials								
<table border="0"> <tr> <td>18</td> <td>Mandated Recyclable</td> <td>25</td> <td>Non-Divertible at MRF</td> </tr> <tr> <td>24</td> <td>Mandated Organic (Non-Divertible at MRF)</td> <td>22</td> <td>Potentially Divertible at MRF</td> </tr> </table>		18	Mandated Recyclable	25	Non-Divertible at MRF	24	Mandated Organic (Non-Divertible at MRF)	22	Potentially Divertible at MRF
18	Mandated Recyclable	25	Non-Divertible at MRF						
24	Mandated Organic (Non-Divertible at MRF)	22	Potentially Divertible at MRF						

3.7 MATERIAL CATEGORIES – VISUAL SURVEYS

The proposed material category list for the C&D Visual Surveys along with indicated divertibility is provided in Table 3-7.

STUDY DESIGN

Table 3-7 Material Categories & Divertibility Classes – C&D/Bulk Visual Survey

Material Category	Material Category
Paper	Glass
1 OCC (Old Corrugated Cardboard) & Kraft	23 Glass
2 Remainder & Composite Other Paper	Organics
Plastic	24 Yard Waste
3 #1 PET Bottles	25 Food Waste
4 Clean Recoverable Film	26 Remainder & Composite Other Organics
5 HDPE Buckets	Construction & Demolition
6 Remainder & Composite Other Plastic	27 Asphalt Paving
Metal	28 Asphalt Shingles
7 Aluminum Beverage Cans	29 Carpet/Padding
8 HVAC Ducting	30 Ceiling Tiles
9 Non-Ferrous	31 Clean Dimensional Lumber
10 Other Ferrous	32 Clean Gypsum Board
Special Waste	33 Clean OSB
11 Appliances/White Goods	34 Concrete/Brick/Rock
12 Batteries - Lead Acid	35 Dirt/Sand/Gravel
13 Bulky Items	36 Insulation
14 Products with Embedded Batteries	37 Other Clean Engineered Wood
15 Electronics	38 Painted/Stained Wood
16 Items with CRTs	39 Treated Wood
17 Tires	40 Pallets/Crates
18 Mercury Containing Products	41 Plywood
19 Other HHW	42 Wood Furniture
20 Paint	43 Remainder & Composite Other C&D
21 Vehicle and Equipment Fluids	
All Other Waste	
22 All Other Wastes not Elsewhere Categorized	
Legend:	
■ Mandated Recyclable	■ Non-Divertible
■ Mandated Organic	■ Potentially Divertible

3.8 DATA COLLECTION METHODS

This study relies on three data collection methods to characterize disposed wastes:

- ◆ **Gate Survey:** For all materials entering the surveyed transfer stations and landfill, this study will survey inbound deliveries to determine the distribution of waste types delivered.
- ◆ **Manual Sampling and Sorting:** For MSW and MRF Residue, this study includes extensive manual sampling and sorting of inbound loads.
- ◆ **Visual Survey of C&D/Bulky Loads:** Loads of C&D and Bulky materials will be visually surveyed using volumetric estimation and industry standard material densities to determine the composition of the loads.

All three data collection methods attempt to representatively sample from the statewide waste stream summarized in Table 2-1.

3.9 SAFETY & HEALTH

MSW Consultants maintains a customized Safety and Health Plan for waste characterization studies. The Safety and Health Plan will be on-site with the MSW Consultants field staff during all phases of field data collection. A copy of this plan is included in Appendix B of this Study Design and will be provided to all host facilities upon request.

4. GATE SURVEY

The purpose of the gate survey is to obtain representative data identifying the breakdown of waste by type and by generator sector. The generator sector for some inbound wastes can likely be determined based on the hauler and on the truck type. However, many frontload and rear-load packer trucks carry both commercial and multi-family wastes, and self-haul loads may be delivered by residential or commercial generators or may contain C&D and/or bulky debris. Survey results will be paired with scale weight data to calculate the precise contribution of single family, multi-family, institutional/commercial/industrial, and C&D/bulky waste for both compacting and non-compacting route trucks.

The following steps are proposed to complete gate surveys that will inform the study with respect to the overall breakdown of load types and generators.

4.1 GATE SURVEY PLAN

- ◆ **Prepare Survey Instrument:** The team will develop a gate survey form to capture truck number and type, hauler, generator sector, and other information that may be needed to develop waste disposal estimates by generator sector.
- ◆ **Site data review:** The team will review recent annual tons by facility as provided by the DEC. Four gate survey days are budgeted, and we anticipate doing one day at four facilities.
- ◆ **Recruit facilities:** Working with the DEC to finalize the targeted facility list, we will recruit the facilities and determine the schedule. The 2018 Gate Surveying Days completed are below. During contracting discussions, it was determined that 4 days will be sufficient to capture enough data to be representative. MSW Consultants anticipates completing the Gate Survey prior to commencing the MSW Sort to confirm sampling plans. We plan to survey the 4 facilities shown in Table 4-1, which manage the highest annual tonnage.

Table 4-1 Anticipated Gate Survey Days

Region	Facilities	2018 Survey Days	2023 Survey Days
CSWD	All Cycle Transfer Station	4	1
Central	Central VT Transfer Station	3	1
CSWD	Burlington Transfer Station	2	
NEK	NEWSVT Direct Landfill	2	1
Rutland	Gleason Road Transfer Station	2	1
Addison	Addison Transfer Station	2	
Windham	Brattleboro Transfer Station	1	
NW	Highgate Transfer Station	1	
SW	TAM Transfer Station	1	
Lammoille	Hyde Park Transfer Station	1	
SW	Manchester Transfer Station	1	
Total		20	4

- ◆ **Gate Surveying:** Inbound vehicles will be surveyed to determine what type of waste is being delivered and the generator sector. To the extent possible, MSW Consultants will work with host facility scalehouse personnel and ask drivers concise questions to determine the material type and generating sector, recording truck type, size, and weight. Gate surveys will be coordinated to the best extent possible to be completed prior to the hand sorts at applicable facilities so results can be used to inform

STUDY DESIGN

the MSW Hand Sort sampling plan. MSW Consultants intends to collect gate survey data on tablet computers using an optimized electronic form. A screen shot of the form is shown in Figure 4-1.

Figure 4-1 Screenshot of Gate Survey Questionnaire

The screenshot shows a mobile application interface for a gate survey questionnaire. At the top, it displays the current date and time (3/30/2023, 10:34:36 AM) and the company name 'WASTEINSIGHT™ Commonwealth of Puerto Rico Residential Refuse'. The form is divided into several sections: Survey ID and Notes, Truck Number, Jurisdiction, Generator(s) with a progress bar showing 100% SF, Hauler information, License/Ticket Number, Minimum weight, and Facility. The main part of the form consists of 13 numbered questions with dropdown menus and checkboxes for answers.

Question Number	Question Text	Answer
1.	Hauler Type	C - Commercial Hauler
2.	Vehicle Type	1. Packer
3.	Material Hauled	R - Refuse
4.	From Construction Site?	<input type="checkbox"/> NO
5.	If yes, from construction site:	select one
6.	Net Weight of Load	1200
7.	Weight Unit of Load	lbs
8.	% Recycle	
9.	MRF Name - If the load is MRF Residue, record the name of the processing facility.	
10.	For Self-Haul only: Does your load have carpet?	<input type="checkbox"/> NO
11.	For Self-Haul only: If yes, what % is carpet?	
12.	For Self-Haul only: If yes, tiles or rolls?	select one
13.	For Self-Haul only: How would you describe your business?	select one

- ◆ **Gate Surveying Summary:** Following completion of the gate surveys, a brief written summary of activities (dates, sites, loads and tons by generator, etc.) will be provided to DEC.

5. FIELD DATA COLLECTION PROCEDURES

5.1 GENERAL SPACE REQUIREMENTS

For the sorting crew to safely and successfully collect and sort samples at each facility, they will need a space approximately the size of two truck bays, or about 20x40 feet. At the end of the day, the crew will have accumulated a large pile of sorted material that will require disposal/processing at the direction of the host facility. Typically, the host facility will make available a bucket loader and operator to periodically clear this material, or a roll-off container will be positioned near the sort area into which sorted refuse or recyclables can be discarded. During the weeks leading up to the field data collection phase, MSW Consultants will be working with each host facility (landfill, transfer station, or MRF) to identify areas where sample collection and sorting can occur.

5.2 LOAD SELECTION

For the manual sorting of refuse, MSW Consultants will be using the results of the gate survey to allocate samples by generator type. The Field Supervisor will ask incoming drivers for basic information which is noted to identify the load. Information from the weight ticket for each vehicle will be obtained for every incoming truck either from the driver, or through communication with the scale house. Once the interview is complete, the Field Supervisor will direct the vehicle to the sampling area.

5.3 SAMPLE ACQUISITION

5.3.1 MSW SAMPLES SELECTION: GRAB SAMPLING

Selected loads of waste designated for sorting will be tipped in the designated area at each host facility. From each selected load, at least one random sample that is representative of the tipped load will be selected based on systematic “grabs” from the perimeter of the load. For example, if the tipped pile is viewed from the top as a clock face with 12:00 being the part of the load closest to the front of the truck, the first samples will be taken from 3 o’clock, 6 o’clock, 9 o’clock, 12 o’clock, and then from 1, 4, 7, and 10 o’clock, and so-on. This concept of systematically rotating around subsequent loads is shown in Figure 5-1.

Figure 5-1 Systematic Sampling Guide for Tipped Loads

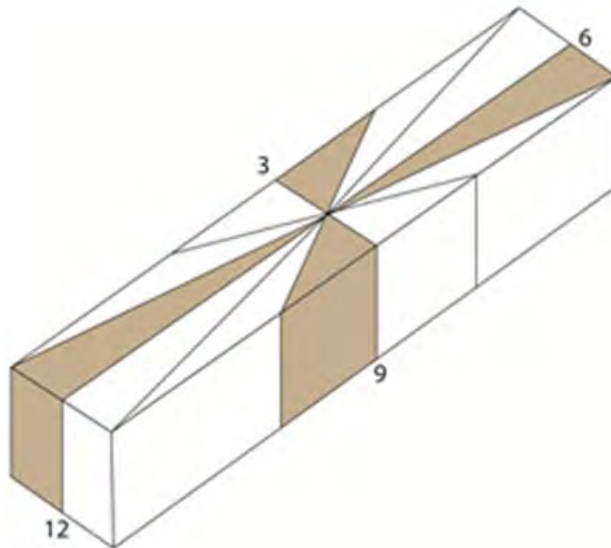

Once the area of the tipped load has been selected, the Field Supervisor will take a photograph of the load with the sample placard and identification number visible in the picture. The Field Supervisor will then coordinate with a facility-provided loader operator to take a “grab” sample of wastes from that point in the tipped load. From each grab, a sample weighing at least 200 pounds will be extracted from the loader bucket and pre-weighed (to verify that the minimum sample weight has been achieved and to prevent sorting overly large samples, which would diminish sorting productivity). Pre-weighed samples will be loaded into barrels for placement on the sort table, although bulky items may be weighed and recorded separately (thereby eliminating the need to characterize them at the sort table).

Depending upon the availability of host facility personnel, the Field Supervisor will either collect the sample directly from the bucket of the front-end loader or will direct the sample to be dumped on a tarp or a paved surface. When collecting samples directly from the loader bucket, 35-gallon cans or carts will be arranged side-by-side on a tarp, with the loader bucket positioned directly overhead. The Field Supervisor will collect the sample systematically, by working from one side of the bucket to the other, emptying all the contents from the front of the bucket to the back, until the desired sample weight is

STUDY DESIGN

achieved. To help minimize sample collection bias, samples will be collected from the loader bucket in an alternating fashion, that is, working from the left side of the bucket to the right side for one sample, and then from right to left on the next sample.

5.3.2 MRF RESIDUE PRE-SORT & RESIDUE SAMPLES

MRF Residue streams are generated through both positive and negative sorting. The sampling procedure for positively sorted residues would be similar to a grab sample, described above. For negatively sorted streams, it may be possible to place a receptacle under the ejection point to accumulate material. Otherwise, a grab method could be used. MSW Consultants will work closely with each host facility and investigate the appropriate method of sample collection during the site visit.

5.4 MANUAL SORTING

Once the sample has been acquired and appropriately staged for sorting, the material will be manually sorted into the prescribed component categories. Plastic 20-gallon bins, 36-gallon barrels, and 5-gallon buckets labeled with the appropriate material category will be used to sort the sampled material. Pictures of the sorting operation at a transfer station and a landfill is shown in Figure 5-2 below. The pictures present the typical layout of the sorting table and bins into which each targeted material is to be sorted. Based on our extensive experience, we believe a well-thought-out sort area is crucial to efficient and accurate sorting. Maintaining a consistent sort area also improves safety by establishing boundaries for all workers to follow consistently.

Figure 5-2 Manual Sorting



5.5 VISUAL SURVEYING

C&D/Bulky characterization project planning and preparation will be completed in conjunction with the planning for the MSW hand sorts. This section summarizes the critical elements that will be undertaken for completion of the C&D/Bulky study.

- ◆ **Locations:** Locations proposed under the Study Design (Task 1) will be confirmed and finalized. Facilities will be contacted to recruit and coordinate schedule and details.
- ◆ **Staffing:** MSW Consultants' professional staff with prior visual characterization experience will conduct the field data collection.
- ◆ **Sample Surveying:** Our assigned staff will coordinate with the scale house, tip area spotter, and inbound deliveries to select loads for surveying. It is understood a loader and operator will be available to assist in spreading the loads from time to time if they are not spread during the offload so we can see the interior of the loads. On most occasions, the driver can spread the load out as it is tipped.

- ◆ **Number of Samples:** MSW Consultants has the capacity to visually characterize from 15 to 25 loads per day, assuming there is sufficient inbound traffic at the host facility. We provide a cost estimate for completing 2 days of surveying per season for up to 50 samples per season (although the number could be lower if load traffic is light).
- ◆ **Sample Selection:** We will select the Nth vehicle based on estimated daily arrivals of C&D/Bulky loads.
- ◆ **Data Collection:** The Visual Survey of a load of bulky or C&D waste involves detailed volumetric measurements of the truck and load dimensions, followed by the systematic observation of the major material components in the tipped load. MSW Consultants utilizes a tablet-based app for visual estimation of C&D loads. The basic steps for visual surveying are as follows:
 1. Measurement and recording of the dimensions of the incoming load prior to tipping and (if possible) an estimate of the percent fullness of the vehicle/container is made.
 2. The load is tipped. If it was a large load of non-homogeneous materials, the loader operator may be asked to spread out the material so that it is possible to discern dense materials such as block, brick, and dirt that tend to sink to the bottom of the pile. Examples of tipped loads are shown in Figure 5-3.

Figure 5-3 Visual Survey of a C&D Loads



3. A first pass is made around the load marking the major material groups that are present in the load—wood waste, organics, paper, etc. The percentage of the load made up of these major groups is then estimated.
4. A second pass is made around the load, noting the secondary material categories contained within each group – for example, within the Wood material group, secondary categories may include wooden pallets, dimensional lumber, painted wood, etc. The percentage of the secondary material category within the primary material groups is then estimated.
5. The app alerts the surveyor if there were any problems with the estimations, for example if the percentages do not sum to 100 percent.
6. Finally, the app compares the volumetrically calculated weight of the load to the actual scale weight of the load. Possible sources of discrepancy can then be identified, and adjustments to volumetric estimates and/or density factors can be made to reduce the degree of difference. This last step is critical to the accuracy of the data. Figure 5-4 provides a screenshot example of the Visual Survey tool.

Figure 5-4 Visual Surveying App Interface (screenshot)

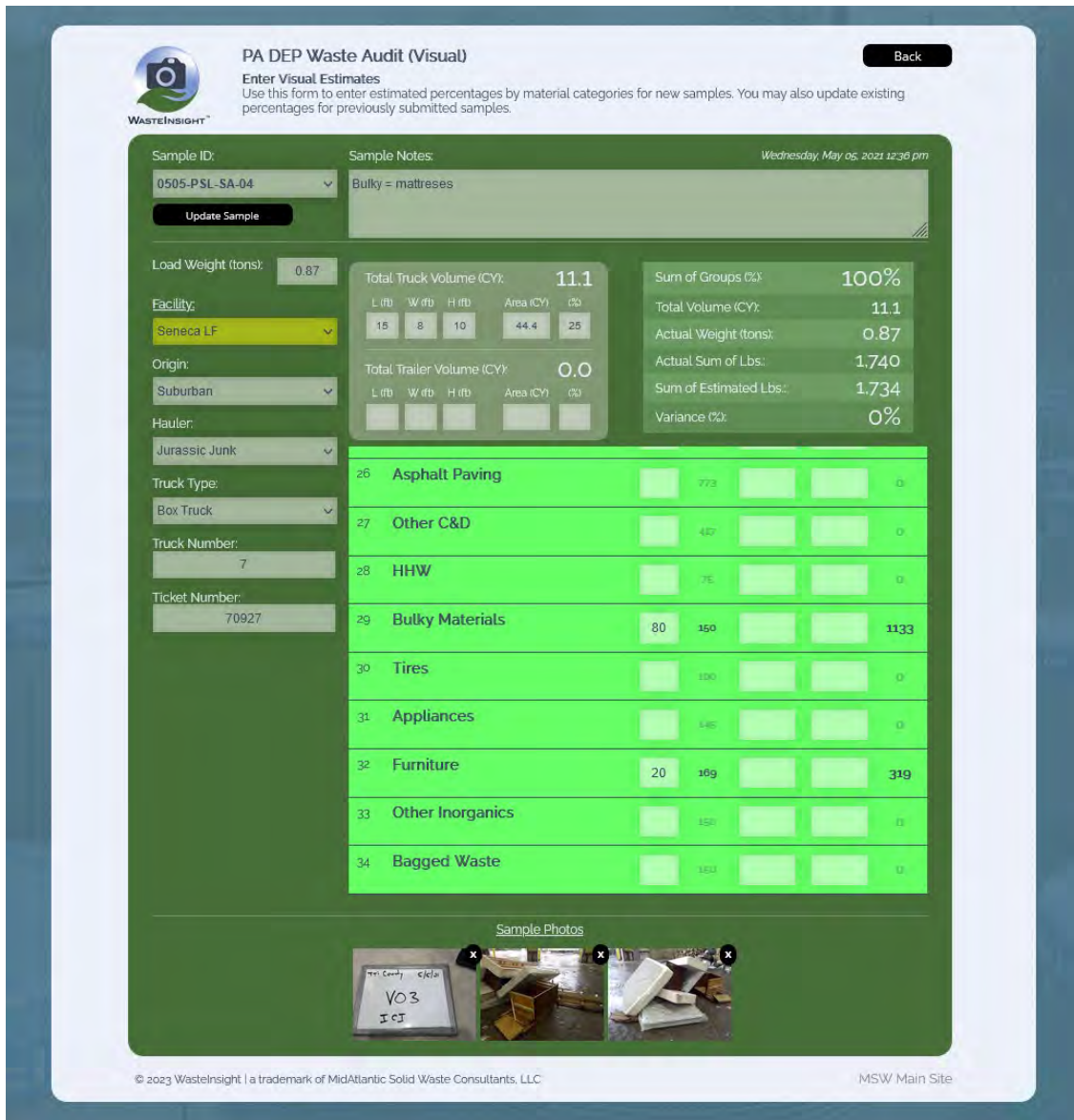

5.6 DATA RECORDING

The weigh-out and data recording process is the most critical of process of the sort. The Crew Chief oversees all weighing and data recording of each sample. Once each sample has been sorted, and fines appropriately characterized, the weigh-out is performed. Each bin containing sorted materials from the just completed samples is then carried over to the scale. Sorting laborers assist with carrying and weighing the bins of sorted material, and the Crew Chief records all data.

The Crew Chief uses a rugged tablet computer to record the composition weights. The tablet allows for samples to be tallied in real time so that field data collection can immediately identify and rectify errors associated with light sample weights. The tablet synchronizes with the cloud via cellular signal, providing excellent data security. Each sample is cross-referenced against the Field Supervisor's tablet data to assure accurate tracking of the samples each day. The real-time data entry offers several important advantages:

- ◆ The template contains built-in logic and error checking to prevent erroneous entries.
- ◆ The template sums sample weights in real time so the Crew Chief can confirm achievement of weight targets for every sample.
- ◆ Except where host facilities are outside of cell phone range, the data file syncs routinely and can be accessed and checked by MSW Consultants QA/QC staff back at the office. For remote facilities that cannot synchronize during the workday, it is usually possible to sync in the evening upon returning to the hotel.

The Crew Chief also carries paper field forms as a back-up in case the tablet computer encounters unforeseen technical difficulties. Figure 5-5 provides an example of the data entry screen.

Figure 5-5 Waste Sort Data Entry Screenshot

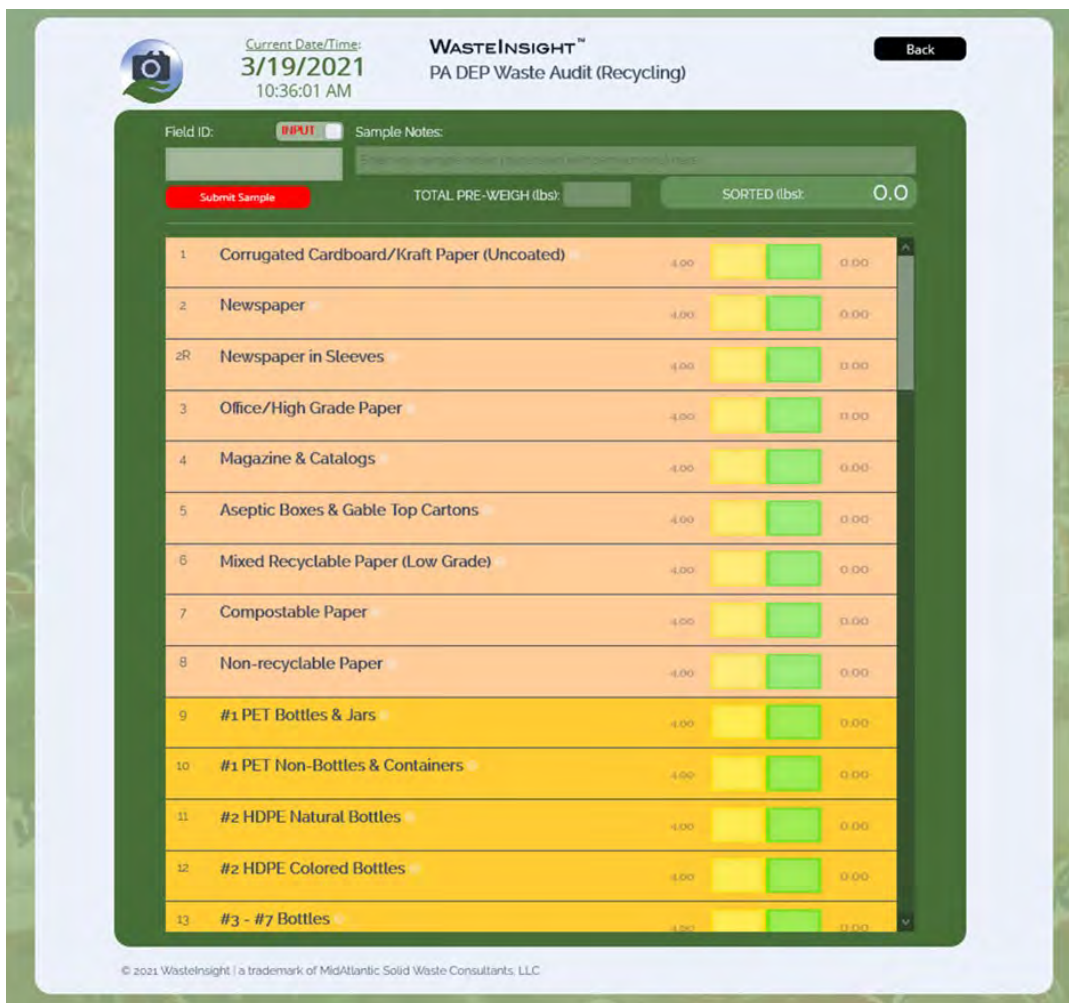

5.7 SITE MAINTENANCE & CLEAN-UP

The Project Team are guests at each of the host facilities, therefore it is critical that the work area is left clean and safe for subsequent operations. Each day will conclude with sufficient time for the sort crew to perform site clean-up. The sorting crew will be responsible for keeping any litter generated by sort operations to a minimum. Clean-up includes the following types of activities:

- ◆ Organized stacking and stowing of sorting supplies in a designated location;

STUDY DESIGN

- ◆ Removal of sorted wastes (the host facility loader operator will help with this);
- ◆ Sweeping and cleaning the sort area to prevent windblown litter and other situations that could attract vectors;
- ◆ Removal and discard of day-use personal protective equipment and decontaminating personnel;
- ◆ Checking out with the Facility Manager each day; and
- ◆ Covering any unsorted samples with a tarp, to be left for sorting the next day.

6. ANALYSIS

Consistent with the 2018 Study, the following statistical measures will be calculated to determine the overall composition of waste composition data (including the MSW hand sorts, MRF residue, and C&D/Bulky wastes).

- ◆ **Sample Mean:** The sample mean, or average, composition is considered the “most likely” fraction for each material category in the waste stream.
- ◆ **Standard Deviation:** The standard deviation measures how widely values within the data set are dispersed from the sample mean. A higher standard deviation denotes higher variation in the underlying samples for each material, while a lower standard deviation reflects lower variation among the individual samples.
- ◆ **Confidence Intervals:** A confidence interval is a statistical concept that attempts to indicate the likely range within which the true value lies. The confidence intervals reflect the upper and lower range within which the population mean can be expected to fall.

Confidence intervals are customarily calculated at a 90 percent level of confidence, meaning that we can be 90 percent sure that the mean falls within the upper and lower confidence intervals shown. We will discuss the advantages and disadvantages of different confidence levels with DEC, and our WasteInsight system allows the user to select different confidence levels. In general, the higher the level of confidence chosen, the wider the confidence intervals.

It should be noted that estimates of C&D sample volumes will be converted to weight-based estimates and normalized in the field. As such, each load will be treated as a sample and analyzed using the same statistical measures. Also note that unlike the percentage based MSW analysis, C&D/Bulky loads will be analyzed by weight, rather than by percentage. This is because heavier C&D/Bulky are given a higher weighting in the overall analysis than lighter C&D/Bulky loads.

7. REPORTING

7.1 PROBLEM IDENTIFICATION REPORTING

To the extent unforeseen problems are encountered during the project, MSW Consultants will undertake the following actions:

- ◆ Promptly alert DEC of the problem via email or phone call.
- ◆ If the problem occurs during data collection and impairs the scheduled completion or performance of the work, we will promptly arrange a conference call to discuss in more detail the consequences and potential resolutions with DEC. A summary write-up will be included in the next scheduled interim report.
- ◆ If a problem with the collected data is identified, it will be described in the interim report. MSW Consultants believes that open communication with DEC will be critical in the event of any difficulties.

7.2 INTERIM REPORTING

Consistent with the 2018 Study, an interim status report will be compiled after the first seasonal sampling and sorting event for the MSW Hand Sort and C&D Visual Survey components of the study. However,

given the extensive data being collected for this project, the interim report will include only aggregate, unweighted composition estimates, which can be used to evaluate the reasonableness of the findings. The MRF Residue Hand Sorting is planned in similar timing as the second season of MSW Hand Sort and C&D Visual Surveying, so no interim reporting is anticipated for the MRF Residue Hand Sort.

7.3 FINAL REPORT PROGRESSION

The 2023 Vermont Statewide Waste Characterization final report will provide extensive details for use by the Vermont DEC's planners and other stakeholders. Submittal of the report to DEC will consist of the following progression:

- ◆ **Report Outline** - MSW Consultants will prepare a report outline and submit it to DEC for approval.
- ◆ **Report Draft** - Upon receiving approval, and upon completion of the data analysis, we will prepare a first draft report that describes the purpose, study methodology, and sampling plan that summarizes the essential composition findings for each waste sector. The 2023 Study report will contain the following elements:
 - ◆ An executive summary providing key findings in standard solid waste industry terminology;
 - ◆ Introduction and background for the study, including objectives;
 - ◆ A description of the methodology used in the study of MSW, C&D/Bulky, and MRF Residue, including final waste category definitions and a summary of the sampling and sorting plan;
 - ◆ A description of the data collection and analytical techniques used;
 - ◆ A summary of the number of samples characterized;
 - ◆ Material composition profiles as described above;
 - ◆ Results of the types and quantities of materials in the waste stream, including recovery rates estimating the recovery of mandated recyclables and food residuals, and a statistical evaluation of data for various categories, as approved by the State, including mandated recyclables and food residuals;
 - ◆ A comparison of the findings against the 2018 Study results as described above;
 - ◆ A summary of findings, conclusions, and supporting documentation (charts, tables, forms, questionnaires, etc.); and
 - ◆ Raw data in Excel format (with discretion to DEC on confidentiality).
 - ◆ The results of the Direct to Broker/Economic recycling survey, Residential Food Scrap Management survey, and Organics Management Transportation survey will be incorporated.
 - ◆ The Project Team anticipates scheduling time to review the Draft Report with DEC to answer questions and receive comments on the Draft Report, including a discussion of the implications of the results for planning purposes.
- ◆ **Final Report** - After receiving input, comments, and requests for changes from DEC, the MSW Project Team will produce the Final Report with all appendices for review and approval by VT DEC.
- ◆ **Presentation** - Finally, MSW Consultants will prepare a PowerPoint summary of the study and present it in-person at a central Vermont location. An electronic copy of the PowerPoint will be delivered to DEC staff.

This page is intentionally left blank.

APPENDIX A

Material Categories & Definitions

This page intentionally left blank.

**2023 Vermont Statewide Waste Characterization Study - MSW Hand Sort
Material Categories and Definitions**

PAPER

- 1 OCC (OLD CORRUGATED CARDBOARD): Corrugated boxes or paper bags made from Kraft paper. Uncoated Corrugated Cardboard has a wavy center layer and is sandwiched between the two outer layers and does not have any wax coating on the inside or outside. Examples include entire cardboard containers, such as shipping and moving boxes, computer packaging cartons, and sheets and pieces of boxes and cartons. This type does not include chipboard. Examples of Kraft paper include paper grocery bags, un-soiled fast food bags, department store bags, and heavyweight sheets of Kraft packing paper.
- 2 BOXBOARD (CHIPBOARD): Chipboard and uncoated paperboard. Examples include cereal boxes and other dry food boxes, toilet paper and paper towel inner tubes, etc.
- 3 NEWSPRINT: The class or kind of paper chiefly used for printing newspapers – i.e. uncoated ground wood paper, including inserts.
- 4 MIXED RECYCLABLE PAPER: Paper other than the paper mentioned above, which can be recycled. Examples include manila folders, manila envelopes, index cards, white envelopes, notebook paper, carbonless forms, junk mail, chipboard and uncoated paperboard, phone directories, non glossy catalogs, offshore cardboard and deep-toned or fluorescent dyed paper.
- 5 MAGAZINES/CATALOGS: Paper items made of glossy coated paper. This paper is usually slick, smooth to the touch, and reflects light. Examples include glossy magazines, catalogs, brochures, and pamphlets.
- 6 HIGH GRADE OFFICE PAPER: Paper that is free of ground wood fibers; usually sulfite or sulphate paper; includes office printing and writing papers such as white ledger, color ledger, envelopes, and computer printout paper, bond, rag, or stationary grade paper. This subtype does not include fluorescent dyed paper or deep-tone dyed paper such as a goldenrod colored paper.
- 7 POLYCOATED/ASEPTIC MULTI-MATERIAL CONTAINERS: Laminated high quality paper cartons used to store drinks without refrigeration. Presumably, milk cartons (gable tops) would be sorted here, which do require refrigeration.
- 8 BOOKS: Softcover and hardcover books.
- 9 COMPOSTABLE PAPER: Low grade paper that is not capable of being recycled, as well as food contaminated paper. Examples include paper towels, paper plates, waxed papers and waxed cardboard, and tissues.
- 10 NON-RECYCLABLE REMAINDER/COMPOSITE PAPER: Items made mostly of paper but combined with large amounts of other materials such as plastic, metal, glues, foil, and moisture. Examples include plastic coated corrugated cardboard, cellulose insulation, blueprints, sepia, onion skin, foiled lined fast food wrappers, frozen juice containers, carbon paper, self-adhesive notes, and photographs.

PLASTICS

- 11a #1 PET BOTTLES - BB: Clear or colored PET bottles that are “VT” deposit containers. When marked for identification, they bear the resin number “1” in the center of the triangular recycling symbol and may also bear the letters “PETE” or “PET”. The color is usually transparent green or clear. A PET container usually has a small dot left from the manufacturing process, not a seam. It does not turn white when bent. This category typically includes deposit PET bottles for carbonated non-alcoholic beverages including sodas, sparkling waters and juices, and carbonated sports and energy drinks; beer, wine coolers, other malt beverages, and pre-mixed spirit cocktails; as well as liquor and spirits.
- 11b #1 PET BOTTLES - EBB: Clear or colored PET bottles, that are NOT marked as “VT” deposit containers. When marked for identification, it bears the resin number “1” in the center of the triangular recycling symbol and may also bear the letters “PETE” or “PET”. The color is usually transparent green or clear. A PET container usually has a small dot left from the manufacturing process, not a seam. It does not turn white when bent. This category will include expanded bottle bill (EBB), PET bottles, which would include non-carbonated water, wine, alcoholic hard cider, and juice bottles as well as non-carbonated energy drinks.
- 11c #1 PET BOTTLES AND JARS - NBB: All PET bottles and jars that would not be subject to either the current VT deposit or an expanded deposit, including dairy products, food products, and other household products.
- 12a #2 HDPE BOTTLES - BB: Natural and Colored HDPE bottles that are "VT" deposit containers. When marked for identification, these bottles bear the resin number “2” in the triangular recycling symbol and may also bear the letters “HDPE. Excludes rice milk, soy milk, milk and dairy. Includes carbonated non-alcoholic beverages including sodas, sparkling waters and juices, and carbonated sports and energy drinks; beer, wine coolers, other malt beverages, and pre-mixed spirit cocktails; as well as liquor and spirits.
- 12b #2 HDPE BOTTLES - EBB: Natural and colored HDPE bottles that are NOT marked as "VT" deposit containers. When marked for identification, they bear the resin number “2” in the triangular recycling symbol and may also bear the letters “HDPE. This category includes HDPE bottles with expanded bottle bill (EBB) products, which would include non-carbonated water, wine, alcoholic hard cider, and juice bottles as well as non-carbonated energy drinks. Excludes rice milk, soy milk, milk and dairy.
- 12c #2 HDPE BOTTLES AND JARS - NBB: All HDPE bottles and jars that would not be subject to either the current VT deposit or an expanded deposit, including dairy products, food products, and other household products.
- 13a #3 - #7 BOTTLES - BB: Plastic bottles made of types of plastic other than HDPE or PET that are also marked for "VT" deposit. Items may be made of PVC, PP, or PS. When marked for identification, these items may bear the resin number 3, 4, 5, 6, or 7 in the triangular recycling symbol. This subtype also includes plastic bottles that are unmarked for resin type. Excludes rice milk, soy milk, milk and dairy. Includes carbonated non-alcoholic beverages including sodas, sparkling waters and juices, and carbonated sports and energy drinks; beer, wine coolers, other malt beverages, and pre-mixed spirit cocktails; as well as liquor and spirits.
- 13b #3 - #7 BOTTLES - EBB: Plastic bottles made of types of plastic other than HDPE or PET that are NOT marked for "VT" deposit and include EBB classes for water and juice bottles, and energy drinks. Items may be made of PVC, PP, or PS. When marked for identification, these items may bear the number 3, 4, 5, 6, or 7 in the triangular recycling symbol. This category will include expanded bottle bill (EBB), #3-#7 bottles, which would include non-carbonated water, wine, alcoholic hard cider, and juice bottles as well as non-carbonated energy drinks. Excludes rice milk, soy milk, milk and dairy. This subtype also includes plastic bottles unmarked for resin type.
- 13c #3 - #7 BOTTLES AND JARS - NBB: All #3-7 bottles and jars that would not be subject to either the current VT deposit or an expanded deposit, including dairy products, food products, and other household products.
- 14 #5 PP FOOD CONTAINERS: All non-bottle polypropylene food containers bearing the No. "5" or "PP" plastic resin type. Examples include #5 yogurt and butter containers and lids that are NOT thermoforms.

2023 Vermont Statewide Waste Characterization Study - MSW Hand Sort
Material Categories and Definitions

- 15 #6 PS RIGID FOOD/BEVERAGE CONTAINERS: All non-bottle polystyrene food and beverage containers bearing the No. "6" or "PS" plastic resin type. Examples include #6 plastic cups, tubs and containers that are NOT thermoforms.
- 16 #6 EPS FOOD/BEVERAGE CONTAINERS: Expanded polystyrene (Styrofoam) containers used to contain food or beverages. Includes EPS cups, clamshells, plates, trays, and similar food-related Styrofoam containers.
- 17 BULKY RIGID PLASTICS > 1 GALLON: Plastic pails, large bottles holding kitty litter and bulk water, and plastic objects other than disposable package items. These items are usually made to last for a few months up to many years. These include 5 gallon pails, large plastic children's toys, plastic furniture, plastic railroad or landscape ties, mop buckets, sporting goods, etc.
- 18 PLASTIC THERMOFORMS: Typically clear plastic packaging used for lettuce, berries, deli foods, which is sometimes called a "clamshell", or other consumer product packaging, no matter which resin it is (#1 thru #7 acceptable). Containers are created by pressing melted plastic into a mold, so it excludes injection molded plastics, which have a raised dot on the bottom. Also excludes all forms of Styrofoam.
- 19 FILM - AGRICULTURE, AND MARINE SHRINK WRAP: Large quantities of bulk film (may be clear, translucent, or white) that is used to cover agricultural fields or used as winterizing shrink wrap on boats.
- 20 FILM - RETAIL BAGS: All plastic bags used to carry groceries and other items purchased at retail stores.
- 21 FILM - GARBAGE BAGS: Bags made specifically to store garbage. Note that bags containing garbage that were once retail bags should be classified as retail bags once the garbage has been emptied out of them.
- 22 FILM - OTHER BAGS: All plastic bags that are not retail bags or garbage bags, including bread bags, bags used in cereal boxes, non-metalized chip and snack bags, sandwich bags, dry cleaning bags, etc. and plastic bags that are contaminated or otherwise non-recyclable. Also includes plastic film mailing pouches and bank bags.
- 23 FILM - OTHER - NON-BAG: All other non-bag film that is not agricultural cover or marine shrink wrap. Examples include painting tarps, food shrink wrap, candy-bar wrappers, and X-ray or photographic film.
- 24 REMAINDER/COMPOSITE/OTHER PLASTIC: Plastic that cannot be put in any other type or subtype. This type includes items made mostly of plastic but combined with other materials. Examples include auto parts made of plastic attached to metal, plastic drinking straws, produce trays, foam packing blocks, foamed polystyrene (including meat trays), plastic strapping, new plastic laminate (e.g., Formica), vinyl, linoleum, plastic lumber, imitation ceramics, handles and knobs, plastic lids, some kitchenware, toys, plastic string (as used for hay bales), and CDs.

METALS

- 25a ALUMINUM BEVERAGE CANS - BB: All aluminum beverage cans containing Carbonated beverages and/or are marked for a "VT" deposit. Includes carbonated non-alcoholic beverages including sodas, sparkling waters and juices, and carbonated sports and energy drinks; beer, wine coolers, other malt beverages, and pre-mixed spirit cocktails. Includes all liquor and spirits.
- 25b ALUMINUM BEVERAGE CANS - EBB: All other aluminum beverage cans not marked for "VT" deposit, but are considered for Expanded Bottle Bill (EBB) coverage. This category will include expanded bottle bill (EBB), aluminum cans, which would include non-carbonated water, wine, alcoholic hard cider, and juice bottles as well as non-carbonated energy drinks. Excludes dairy and dairy-related.
- 26 ALUMINUM FOIL, PANS, AND CONTAINERS - NBB: Non-beverage cans and containers, and foil made from 100 percent aluminum. Includes aluminum cooking pans. Includes aluminum pet food cans.
- 27 FERROUS CONTAINERS: Rigid containers made mainly of steel, such as soup or other canned food containers. These items will stick to a magnet and may be tin-coated.
- 28 OTHER FERROUS: Any iron or steel that is magnetic. This subtype does not include "tin/steel containers". Examples include empty or dry paint cans, structural steel beams, boilers, metal clothes hangers, metal pipes, some cookware, security bars, appliances, and scrap ferrous items and galvanized items such as nails and flashing.
- 29 OTHER NON-FERROUS: Any metal item that is not magnetic, as well as stainless steel. These items may be made of copper, brass, bronze, lead, zinc, or other metals. Examples include copper wire, shell casings, and brass pipe.

GLASS

- 30a GLASS BEVERAGE BOTTLES - BB: Clear or colored glass bottles that are "VT" deposit containers. This category includes deposit glass bottles for carbonated non-alcoholic beverages including sodas, sparkling waters and juices, and carbonated sports and energy drinks; beer, wine coolers, other malt beverages, and pre-mixed spirit cocktails; as well as liquor and spirits.
- 30b GLASS BEVERAGE BOTTLES - EBB: Clear or colored glass bottles, that are NOT marked as "VT" deposit containers. This category will include expanded bottle bill (EBB), glass bottles, which would include non-carbonated water, wine, alcoholic hard cider, and juice bottles as well as non-carbonated energy drinks. Excludes rice milk, soy milk, milk and dairy.
- 30c GLASS BEVERAGE BOTTLES AND JARS - NBB: All glass bottles and jars that would not be subject to either the current VT deposit or an expanded deposit, including dairy products, food products, and other household products.
- 31 OTHER GLASS: All non-container glass, including, for example Pyrex, Corningware, crystal and other glass tableware, mirrors, plate glass (e.g. window or from picture frame), non-fluorescent light bulbs, auto windshields, laminated glass, or any curved glass.

2023 Vermont Statewide Waste Characterization Study - MSW Hand Sort
Material Categories and Definitions

ORGANIC

- 32 FOOD WASTE - CONTAINED IN PACKAGING: Food material, either loose or not in original packaging, resulting from the processing, storage, preparation, cooking, handling, or consumption of food. This type includes material from industrial, commercial, or residential sources. Examples include discarded meat scraps, dairy products, eggshells, fruit or vegetable peels, and other food items from homes, stores and restaurants. May include the bag or other container holding the food if the bag/container weight is insignificant compared to the contained food.
- 33 FOOD WASTE - UNPACKAGED: Unconsumed packaged food products still in retail or factory packaging. If possible, food should be emptied out of packaging into this bin; the packaging should then be sorted in its appropriate category.
- 34 BRANCHES & STUMPS >1": Trees, stumps, branches, or other wood generated from clearing land for commercial or residential development, road construction, agricultural land clearing, storms, or natural disaster; and large prunings and trimmings. Items in this category are larger than 1 inch in diameter.
- 35 LEAVES, GRASS, & BRUSH <1": Leaves and grass as well as small trees, stumps, branches, or brush generated from commercial or residential yard maintenance, development, road construction, agricultural land clearing, storms, or natural disaster; Includes small prunings and trimmings. Items in this category are smaller than 1 inch in diameter.
- 36 WOOD - CLEAN: Wood that has not been painted, stained, or treated. This category includes clean, dimensional lumber, but excludes plywood, oriented strand board and fiberboard.
- 37 PET WASTE: Dog and cat waste, including cat waste contained in kitty litter.
- 38 OTHER ORGANICS: Organic material that cannot be put in any other type or subtype. This type includes items made mostly of organic materials but combined with other materials. Examples include cork, hemp rope, hair, cigarette butts, full vacuum bags, sawdust, and (non-pet) animal feces.

ELECTRONICS

- 39 BANNED - NON-CED ELECTRONICS: All personal digital assistants (PDAs), telephones, personal music players, VCR's, DVD players, electronic game consoles, fax machine, answering machines, digital converter boxes, power supply cords, and stereo equipment.
- 40 CEDS - CRTS: "Covered Electronic Devices" (CEDs) that are "Cathode Ray Tube" (CRTs) stand-alone computer screens that contain leaded glass.
- 41 CEDS - COMPUTER PERIPHERALS : CED items related to computers but do not possess any computing capability. Includes mice, keyboards, or webcams. Does not include CRTs or printers.
- 42 CEDS - DESKTOP COMPUTERS: Desktop computers of any type.
- 43 CEDS - LAPTOPS/TABLETS : Laptop computers or tablets of any type.
- 44 CEDS - PRINTERS: Computer printers of any type.
- 45 CEDS - TELEVISION/MONITORS (NON-CRT): Non cathode ray tube type televisions or computer monitors. Includes flat-screen televisions or computer monitors.
- 46 PRODUCTS WITH EMBEDDED BATTERIES: Any electrical product not listed above that has an embedded battery system. May include electronic children's toys, watches, or similar items.
- 47 SMALL APPLIANCES: Items such as a microwave or coffee maker typically found in a kitchen or bathroom.
- 48 WHITE GOODS: Large appliances such as refrigerators, ranges, water heaters, freezers, unit air conditioners, washing machines, clothes dryers and other similar large domestic and commercial appliances.

HOUSEHOLD HAZARDOUS WASTE

- 49 BATTERIES - LEAD ACID: Heavy batteries used for cars and other motor vehicles. These batteries are predominantly made up of lead and acid. Includes marine batteries.
- 50 BATTERIES - PRIMARY: Any type of unchargeable battery including household batteries such as AA, AAA, D, button cell, and 9 volt.
- 51 BATTERIES (RECHARGEABLE): Rechargeable batteries typically used in cordless phones and power tools, lap top computers, video cameras, and many other common products. Includes nickel-cadmium, nickel-metal hydride, lithium ion batteries.
- 52 MERCURY CONTAINING PRODUCTS - LAMPS: Mercury-containing compact fluorescent lamps (CFLs).
- 53 MERCURY CONTAINING PRODUCTS - THERMOSTATS: Mercury-containing thermostats and switches, including older light switches and automotive switches. Also includes mercury containing thermometers.
- 54 MERCURY CONTAINING PRODUCTS- OTHER: Other mercury-containing products, such as fluorescent light ballasts and some small electronic products.
- 55 PAINT: Oil and latex-based paints.
- 56 OTHER HHW: All materials typically accepted at a HHW collection day including vehicle automotive fluids, paint thinners, lacquers, medicines, medical products, poisons (pesticides and herbicides) corrosives, flammables, and sharps.

CONSTRUCTION & DEMOLITION (C&D) MATERIALS (In the MSW Stream)

- 57 ASPHALT, BRICK AND CONCRETE (ABC): Pieces of asphalt paving, bricks and concrete.
- 58 ASPHALT SHINGLES: Roofing shingles containing asphalt.
- 59 C & D METAL: HVAC metals, rebar, steel and aluminum framing materials, and other metal typically found in construction and demolition materials.
- 60 DRYWALL / GYPSUM BOARD: Drywall, sheetrock, or gypsumboard. Can be clean, painted, or wallpapered.
- 61 ORIENTED STRAND BOARD: An engineered wood-based structural panel made using waterproof heat-cured adhesives and rectangularly shaped wood strands that are arranged in cross-oriented layers.
- 62 OTHER/RESIDUAL C & D: All other construction and demolition debris, including plastic buckets and film clearly used in the construction process, fiberboard, clay pipe, electrical wire, fixtures, etc.
- 63 WOOD - PAINTED AND TREATED : Wood that has been painted or stained, and wood that has been treated with a wood preservative.
- 64 PLYWOOD: Laminated 4' x 8' sheets of wood, or pieces of sheets.

**2023 Vermont Statewide Waste Characterization Study - MSW Hand Sort
Material Categories and Definitions**

SPECIAL/OTHER WASTES

- 65 CARPET & CARPET PADDING: Flooring applications consisting of various natural or synthetic fibers bonded to some type of backing material. Carpet Padding means plastic, foam, felt, or other material used under carpet to provide insulation and padding.
- 66 DIAPERS / SANITARY PRODUCTS: Includes both baby diapers and adult diapers (cloth and paper/plastic) and women's sanitary pads and tampons.
- 67 FINES/DIRT/MIXED RESIDUE: Material passing through a 1/2 inch screen which is not otherwise categorized.
- 68 FURNITURE / BULKY ITEMS: Large, hard to handle items that are not defined separately. Examples include all sizes and types of furniture, mattresses, box springs, and base components.
- 69 RUBBER: Any material made of rubber other than vehicle tires.
- 70 TEXTILES AND LEATHER: Includes clothing, fabrics, curtains, blankets, stuffed animals, and other cloth material.
- 71 TIRES: Any vehicle tire.

MIXED RESIDUE

- 72 ALL OTHER WASTES NOT ELSEWHERE CATEGORIZED: Any other type of waste material not listed in any other sort category.

2023 Vermont Statewide Waste Characterization Study
Construction and Demolition Load Visual Survey
Material Categories and Definitions

PAPER

- 1 OCC (OLD CORRUGATED CARDBOARD) & KRAFT: Corrugated boxes or paper bags made from Kraft paper. Uncoated Corrugated Cardboard has a wavy center layer and is sandwiched between the two outer layers and does not have any wax coating on the inside or outside. Examples include entire cardboard containers, such as shipping and moving boxes, computer packaging cartons, and sheets and pieces of boxes and cartons. This type does not include chipboard. Examples of Kraft paper include paper grocery bags, un-soiled fast food bags, department store bags, and heavyweight sheets of Kraft packing paper.
- 2 REMAINDER & COMPOSITE OTHER PAPER: Multi-page bound paper items (glued or stapled) made of glossy coated paper. This paper is usually slick, smooth to the touch, and reflects light. Examples include glossy magazines, catalogs, brochures, and pamphlets. Does not include newspaper inserts. Other items primarily paper but mixed with other materials (metal, plastic, etc.) so the item would not be recyclable.

PLASTICS

- 3 #1 PET BOTTLES: Clear or colored PET bottles. When marked for identification, they bear the resin number “1” in the center of the triangular recycling symbol and may also bear the letters “PETE” or “PET”. The color is usually transparent green or clear. A PET container usually has a small dot left from the manufacturing process, not a seam. It does not turn white when bent. For C&D visual characterization, this category may not be able to distinguish bottle bill classification. As the weight of a single bottle is minuscule in comparison to typical C&D loads, PET bottle weight will be estimated based on a COUNT of PET bottles observed and current weight of manufactured bottles.
- 4 CLEAN RECOVERABLE FILM: Usually in the form of clean industrial film.
- 5 HDPE BUCKETS: High Density Polyethylene Buckets
- 6 REMAINDER & COMPOSITE OTHER PLASTIC: All other plastic materials including rigid plastic components, expanded foam plastics, non-recyclable film plastics, and items that are substantially plastic but with other components (metal, paper, etc.) so the item would not be recyclable.

GLASS

- 7 GLASS: All Glass Materials

ORGANIC

- 8 YARD WASTE: Plant material from any public or private landscapes. Examples include leaves, grass clippings, sea weed, plants, prunings, shrubs. Limbs, logs, and stumps generated by removing vegetation from public or private land by mechanical or manual means.
- 9 FOOD WASTE: Food waste of visible quantities, may be packaged or unpackaged.
- 10 REMAINDER & COMPOSITE OTHER ORGANICS: Organic material that is not yard waste. May include large quantities of animal wastes, or other organic material.

CONSTRUCTION & DEMOLITION (C&D) MATERIALS

- 11 ASPHALT PAVING: Pieces of asphalt paving, bricks and concrete.
- 12 ASPHALT SHINGLES: Asphalt shingles and tar roofing paper. Does not include wood or metal roofing material.
- 13 CARPET/PADDING: Flooring applications consisting of various natural or synthetic fibers bonded to some type of backing material. Carpet Padding means plastic, foam, felt, or other material used under carpet to provide insulation and padding.
- 14 CEILING TILES: Ceiling tiles and panels including: wet pressed mineral fiber, perlite, fiberglass, gypsum wall-board, metal tiles and panels, and wood or agri-based composite tiles and panels.
- 15 CLEAN DIMENSIONAL LUMBER: Cut dimensional lumber that has not been painted, stained, or treated. This category excludes plywood, oriented strand board and fiberboard.
- 16 CLEAN GYPSUM BOARD: Clean, unused gypsum board building material or sheetrock.
- 17 CLEAN OSB: Clean Oriented Strand Board, an engineered wood-based structural panel made using waterproof heat-cured adhesives and rectangularly shaped wood strands that are arranged in cross-oriented layers.
- 18 CONCRETE/BRICK/ROCK: Concrete, brick or rock construction materials.
- 19 DIRT/SAND/GRAVEL: Materials made of dirt or sand, often left over from land clearing activities. Gravel includes pathway gravel and other natural or mechanically crushed aggregate rock.
- 20 INSULATION: Materials used for weather or sound barrier, typically fiberglass or cellulose materials, in various forms such as long strips/bats, wallboards, expanded foam, small blown-in particles.
- 21 OTHER CLEAN ENGINEERED WOOD: Other clean engineered wood including particleboard and fiberboard. Does not include plywood or OSB.
- 22 PAINTED/STAINED WOOD: Lumber or wood materials that have been painted or stained.
- 23 TREATED WOOD: Wood that has had an external coating applied, been pressure treated, chemically treated (with copper etc.) or treated with creosote. Examples include railroad ties, marine timbers and pilings, landscape timbers, and telephone poles.
- 24 PALLETS/CRATES: Wood pallets, crates and spools used for shipping or storage of goods, whether painted, unpainted, or made of engineered lumber.
- 25 PLYWOOD: Plywood consists of a strong, thin wooden board comprised of two or more layers glued and pressed together with the direction of the grain alternating, and usually found in 4' x 8' sheets.
- 26 WOOD FURNITURE: Furniture products made mostly of wood.
- 27 REMAINDER & COMPOSITE OTHER C&D: All other construction and demolition debris, including plastic buckets and film clearly used in the construction process, fiberboard, clay pipe, electrical wire, fixtures, etc.

2023 Vermont Statewide Waste Characterization Study
Construction and Demolition Load Visual Survey
Material Categories and Definitions

METALS

- 28 ALUMINUM BEVERAGE CANS: Aluminum cans. For C&D visual characterization, this category may not be able to distinguish each can's bottle bill classification. As the weight of a single can is minuscule in comparison to typical C&D loads, Aluminum beverage can weight will be estimated based on a COUNT of Aluminum cans observed and current weight of manufactured cans.
- 29 HVAC DUCTING: Conduits or passages to deliver and remove air. Could be made from a variety of materials such as galvanized steel, aluminum, plastic or fiberglass.
- 30 NON-FERROUS: Non-magnetic metals such as aluminum, brass, bronze, silver, lead copper, zinc, and stainless steel.
- 31 OTHER FERROUS: Ferrous and alloyed ferrous scrap materials originated from residential commercial, or institutional sources which are attracted to a magnet. Includes rebar, empty paint cans.

SPECIAL WASTES

- 32 APPLIANCES/WHITE GOODS*: Household machines that use electricity and, in some cases, freon. Examples: refrigerators, stoves, washers, dryers, freezers, dishwashers.
- 33 BATTERIES - LEAD ACID*: Heavy batteries used for cars and other motor vehicles. These batteries are predominantly made up of lead and acid. Includes marine batteries.
- 34 BULKY ITEMS: Large, hard to handle items that are not defined separately. Examples include all sizes and types of furniture, mattresses, box springs, and base components. Does not include wood furniture.
- 35 PRODUCTS WITH EMBEDDED BATTERIES: Any electrical product that has an embedded battery system. May include electronic children's toys, watches, or similar items.
- 36 ELECTRONICS *: Includes computers, monitors, printers, televisions, stereos, VCRs, DVD players, etc. Does not include items with CRTs.
- 37 ITEMS WITH CRTS*: "Covered Electronic Devices" (CEDs) that are "Cathode Ray Tube" (CRTs) stand-alone computer screens that contain leaded glass.
- 38 TIRES*: Includes all synthetic, natural rubber, pneumatic or solid core tires.
- 39 MERCURY CONTAINING PRODUCTS*: Includes items such as thermostats and mercury-containing lightbulbs.
- 40 OTHER HHW*: All materials typically accepted at a HHW collection day including paint thinners, lacquers, medicines, medical products, poisons (pesticides and herbicides) corrosives, flammables, and sharps.
- 41 PAINT*: Oil and Latex-based paints.
- 42 VEHICLE AND EQUIPMENT FLUIDS*: Vehicle fluids including oils, lubricants, coolants, etc.

MSW

- 43 MIXED MSW: Household and job site waste that is bagged or loose and consists primarily of municipal solid waste. Examples include bagged garbage, beverage containers, and other refuse generated on construction sites by non-C&D activities (i.e., consumption by on-site staff), as well as bagged MSW deposited by third parties in collection containers.

PAPER

- 1 OCC:Corrugated boxes or paper bags made from Kraft paper. Uncoated Corrugated Cardboard has a wavy center layer and is sandwiched between the two outer layers and does not have any wax coating on the inside or outside. Examples include entire cardboard containers, such as shipping and moving boxes, computer packaging cartons, and sheets and pieces of boxes and cartons. This type does not include chipboard. Examples of Kraft paper include paper grocery bags, un-soiled fast food bags, department store bags, and heavyweight sheets of Kraft packing paper.
- 2 BOXBOARD (CHIPBOARD):Chipboard and uncoated paperboard. Examples include cereal boxes and other dry food boxes, toilet paper and paper towel inner tubes, etc.
- 3 MIXED RECYCLABLE PAPER:Paper other than the paper mentioned above, which can be recycled. Examples include manila folders, manila envelopes, index cards, white envelopes, notebook paper, carbonless forms, junk mail, chipboard and uncoated paperboard, phone directories, non glossy catalogs, offshore cardboard and deep-toned or fluorescent dyed paper.
- 4 POLYCOATED / ASEPTIC CONT.:Laminated high quality paper cartons used to store drinks without refrigeration.
- 5 COMPOSTABLE PAPER:Low grade paper that is not capable of being recycled, as well as food contaminated paper. Examples include paper towels, paper plates, waxed papers and waxed cardboard, and tissues.
- 6 NON-RECYCLABLE, REMAINDER/COMPOSITE PAPER:Items made mostly of paper but combined with large amounts of other materials such as plastic, metal, glues, foil, and moisture. Examples include plastic coated corrugated cardboard, cellulose insulation, blueprints, sepia, onion skin, foiled lined fast food wrappers, frozen juice containers, carbon paper, self-adhesive notes, and photographs.

PLASTIC

- 7 #1 PET BOTTLES & JARS:Clear or colored PET bottles, jugs, or jars typically have a narrow neck that may or may not be marked for "VT" deposit . When marked for identification, they bear the resin number "1" in the center of the triangular recycling symbol and may also bear the letters "PETE" or "PET". The color is usually transparent green or clear. A PET container usually has a small dot left from the manufacturing process, not a seam. It does not turn white when bent. This category typically includes water, sodas, sparkling waters, juices, sports and energy drinks, alcoholic beverages, and household products.
- 8 #1 PET OTHER CONTAINERS:Clear or colored #1 PET containers such as thermoforms or "clam shells" and trays that may be used for packaging produce, eggs, and deli foods as well as non-food retail packaging.
- 9 #2 HDPE BOTTLES & JARS:Natural and Colored HDPE bottles, jugs or jars that have a narrow neck and may or may not be marked for "VT" deposit. When marked for identification, these products bear the resin number "2" in the triangular recycling symbol and may also bear the letters "HDPE". Examples include milk and other dairy products, carbonated and non-carbonated beverages, plant-based beverages, infant formula, alcoholic beverages, food and household products.
- 10 #2 HDPE OTHER CONTAINERS:Natural and Colored HDPE containers that typically have a wide mouth and may or may not be marked for "VT" deposit. When marked for identification, these products bear the resin number "2" in the triangular recycling symbol and may also bear the letters "HDPE". Examples include food and household products.
- 11 #3 PVC:Products or packaging that bear the resin number "3" in the triangular recycling symbol and may also bear the letters "PVC". PVC packaging sometimes has a blue tint. Examples include rigid packaging, PVC pipe, and some household product bottles (glues, oils).
- 12 #5 PP BOTTLES & JARS:Clear or colored #5 PP bottles, jugs, or jars typically have a narrow neck that may or may not be marked for "VT" deposit . When marked for identification, they bear the resin number "5" in the center of the triangular recycling symbol and may also bear the letters "PP". Examples include some brands of ice tea and some food-related bottles.
- 13 #5 PP OTHER CONTAINERS:All non-bottle polypropylene food containers bearing the No. "5" or "PP" plastic resin type. Examples include #5 yogurt and butter containers and lids that are NOT thermoforms.
- 14 #6 EXPANDED POLYSTYRENE (EPS):Expanded polystyrene (Styrofoam) containers used to contain food or beverages. Includes EPS cups, clamshells, plates, trays, and similar food-related Styrofoam containers as well as EPS packaging such as foam blocks or peanuts.
- 15 BULKY PLASTIC:Oversized single resin plastic items with little to no other materials. Examples include plastic laundry baskets, some plastic furniture, large plastic toys, plastic trash cans. Excludes multi-material plastic items such as childrens car seats, insulated coolers, plastic chairs with metal legs.
- 16 FILM PLASTIC:Film Plastic
- 17 OTHER RIGID PLASTIC:All Other Plastic not captured in the categories above, and multi-material items that are primarily plastic but may have other materials attached such as paper, glue, metals, etc.

GLASS

- 18 GLASS BOTTLES & JARS:All recyclable glass bottles and jars.

METAL

- 19 AL. BEV CANS:All aluminum beverage containing that may or may not be marked for "VT" deposit.
- 20 AL. FOIL, PANS, AND CONTAINERS:Non BB or EBB containers and foil made from 100 percent aluminum used to protect food, and aluminum cooking pans. Includes aluminum pet food containers.
- 21 FERROUS CONTAINERS:Rigid containers made mainly of steel, such as soup or other canned food containers. These items will stick to a magnet and may be tin-coated.
- 22 OTHER FERROUS:Any iron or steel that is magnetic. This subtype does not include "tin/steel containers". Examples include empty or dry paint cans, structural steel beams, boilers, metal clothes hangers, metal pipes, some cookware, security bars, appliances, and scrap ferrous items and galvanized items such as nails and flashing.
- 23 OTHER NON-FERROUS:Any metal item that is not magnetic, as well as stainless steel. These items may be made of copper, brass, bronze, lead, zinc, or other metals. Examples include copper wire, shell casings, and brass pipe.

ORGANICS

- 24 FOOD WASTE:Food Waste - packaged or unpackage

HOUSEHOLD HAZARDOUS WASTE

- 25 BATTERIES:Any type of unchargeable battery including household batteries such as AA, AAA, D, button cell, and 9 volt. Also includes rechargeable batteries typically used in cordless phones and power tools, lap top computers, video cameras, and many other common products. Includes nickel-cadmium, nickel-metal hydride, lithium ion batteries.
- 26 OTHER HHW:All materials typically accepted at a HHW collection day including vehicle automotive fluids, paint thinners, lacquers, medicines, medical products, poisons (pesticides and herbicides) corrosives, flammables, and sharps. For MRF Residual sort includes paints, lead acid batteries & mercury containing products (items sorted individually in MSW hand sort).

OTHER WASTES

- 27 ALL OTHER WASTES NOT ELSEWHERE CATEGORIZED:Any other type of waste material not listed in any other sort category.
- 28 2-INCH MINUS MATERIALS:Material passing through a 2-inch screen which is not otherwise categorized.
- 29 BAGGED MATERIALS:Materials at points of infeed that are bagged. Materials may be sub-sorted to identify actual contents (e.g., recyclables, other wastes, etc.)

This page intentionally left blank.

APPENDIX B
Safety and Health Plan

This page intentionally left blank.

Safety & Health Plan for Waste Composition Analysis





This Safety and Health Plan was delivered electronically. If it is necessary to print hard copies, please do so on post-consumer recycled paper and recycle.



TABLE OF CONTENTS

1. INTRODUCTION	1
1.1. Statement of Safety and Health Policy.....	2
2. PROGRAM MANAGEMENT	2
2.1. Background Information	2
2.2. Safety and Health Framework.....	3
2.3. Subcontractors.....	3
2.4. Training Requirements	4
2.4.1 MSW Employees.....	4
2.4.2 Facility-Specific Training (Employees and Subcontractors)	4
2.5. Client Personnel and Visitors	4
2.6. Physical Qualification of Employees.....	4
2.7. Roles and Responsibilities.....	5
2.7.1 Corporate Safety and Health Managers.....	5
2.7.2 Field Supervisor	5
2.7.3 Subcontractors.....	6
2.7.4 Communications	7
2.8. Accident Reporting.....	7
2.9. Emergency Planning.....	7
2.10. Post-Job Safety Performance Reviews.....	7
3. SANITATION	8
3.1. Drinking Water.....	8
3.2. Toilets and Washing Facilities	8
3.3. Waste Disposal	8
3.4. Vermin Control	8
4. MEDICAL AND FIRST AID REQUIREMENTS	8
4.1. First Aid Kits	9
4.2. First Aid Stations and Infirmarys.....	9
5. PERSONAL PROTECTIVE EQUIPMENT (PPE)	9
5.1. Gloves.....	10
5.2. Eye Protection	11
5.3. Respiratory Protection.....	12
5.4. Plastic Face Shields	12
5.5. Footwear.....	13
5.6. Protective Suits	13
5.7. Other PPE.....	14

TABLE OF CONTENTS

6. HAZARDOUS SUBSTANCES AND ENVIRONMENTS	14
6.1. Hazardous Substances.....	14
6.2. Harmful Plants, Animals, and Insects.....	15
6.3. Inclement Weather and Environmental Hazards.....	15
6.4. Decontamination.....	16
6.4.1 Additional procedures for cleaning and disinfecting job-site surfaces	17
6.4.2 Guidance for daily home laundering of work site clothing.....	18
6.5. Personnel Decontamination.....	18
7. MATERIAL HANDLING	18
7.1. Lifting and Carrying.....	19
7.2. Temporary Material and Equipment Storage.....	19
7.3. Housekeeping	19
7.4. Material Disposal.....	20
8. SITE CONTROL.....	20
8.1. Sampling Area Controls	20
8.2. Sorting Area Controls.....	20

LIST OF APPENDICES

APPENDIX A - PLAN APPROVAL AND SIGN OFF FORM

APPENDIX B - ACCIDENT OR INJURY REPORT

APPENDIX C - HAZARD ASSESSMENT AND CORRECTION RECORD

TABLE OF CONTENTS

List of Figures

Figure 2-1 Safety and Health Plan Framework	3
Figure 5-1 MSW Consultants Preferred Glove	11
Figure 5-2 MSW Consultants Preferred Eye Protection.....	12
Figure 5-3 MSW Consultants Preferred Respiratory Protection	12
Figure 5-4 Plastic Face Shield	13
Figure 5-5 Tyvek Coveralls.....	14

List of Tables

Table 6-1 Symptoms and Treatment of Heat and Cold Stress	16
Table 6-2 Decontamination Procedures.....	18

This page intentionally left blank.

SAFETY AND HEALTH PLAN

1. INTRODUCTION

This Safety and Health Plan (SAHP) has been written for use by MSW Consultants, LLC, (MSW Consultants) personnel, their subcontractors, and any other individuals authorized access to areas where site control is established to conduct field work associated with the performance of a physical or visual composition study of municipal solid wastes.

It should be noted that PPE requirements as suggested by OSHA in response to the coronavirus (COVID-19) have been a standard requirement by MSW Consultants on all projects pre-dating this pandemic. Such PPE will continue to be required on all projects going forward. Added text has been inserted in the SAHP below that include additional measures to be undertaken that have been implemented since COVID-19¹.

MSW Consultants is responsible for the physical sampling and sorting at facilities, therefore this HASP concentrates on the essential safety aspects for physical sorting. While physical sampling and sorting will be performed by MSW Consultants, it is expected that anyone entering the field will follow MSW's Health and Safety Plan.

MSW Consultants does not guarantee the health and safety of any person entering the designated work areas. Because of the nature of this work and the activity occurring therein, it is not possible to discover, evaluate, and provide protection for all possible hazards that may be encountered. Strict adherence to these health and safety guidelines will reduce, but not eliminate, the potential for injury or exposure to hazards on the site. The health and safety guidelines in this plan were prepared generally for this type of field activity. It may be necessary to refine this plan for each individual project, depending on local site characteristics and job requirements.

The following practices are included in this document:

- ◆ Safety and health framework at host municipal solid waste facilities;
- ◆ Sampling hazard evaluation and controls;
- ◆ Sorting hazard evaluation and controls;
- ◆ Fundamental safe work practices including site controls;
- ◆ Personnel protective equipment (PPE) applicable the field work; and
- ◆ Emergency response procedures.

A copy of this SAHP will be maintained by the MSW Consultants Field Supervisor at all times while field operations are in progress. A copy of the SAHP will be provided to the client, facility management, subcontractors, and other project stakeholders at their request. Each employee (MSW Consultants or subcontractor) is required to receive basic training on the safety and health principals and procedures contained herein at the outset of the project and sign a release documenting receipt of such training.

¹ [Cdc.gov/coronavirus](https://www.cdc.gov/coronavirus)

SAFETY AND HEALTH PLAN

1.1. STATEMENT OF SAFETY AND HEALTH POLICY

It is the policy of MSW Consultants to conduct all work in a manner that minimizes the physical and chemical/biological hazards to which workers might be exposed in the course of their work. MSW consultants also will conduct emergency planning in such a way as to minimize the consequences of any accident or exposure for their employees and subcontractors. MSW Consultants will provide adequate training and supervision to all employees performing work on a given project and will be responsible for ensuring all employees and subcontractors follow the provisions of the Safety and Health Plan developed for that project.

Safety is basic or inherent to the work performed by MSW Consultants. Each employee (MSW Consultants or subcontractor) is held accountable and responsible for working safely, including following the procedures and guidance of this SAHP. All employees are required to comply with applicable safety regulations. Individuals who do not follow the procedure and guidance of this SAHP are subject to removal from the site and project.

In addition to this policy, MSW Consultants will hold the project and corporate staff responsible for the safe conduct of work during this project, according to the roles and responsibilities described herein. Any willful violation of the provisions of this plan is grounds for immediate discipline or dismissal.

2. PROGRAM MANAGEMENT

Safety is an essential part of field operations management function and responsibility. It is the responsibility of MSW Consultants designated field operations manager to see that each person under this project understands and complies with all safety rules and requirements. This section presents the general background and guidelines for implementing and complying with safety and health requirements for waste composition studies.

2.1. BACKGROUND INFORMATION

Contractor: MSW Consultants, LLC
Corporate Address: 11875 High Tech Avenue
Suite 150
Orlando, FL 32817
Phone: (800) 679-9220

Designated Field Supervisor:

Client:

Brief Project Name:

Brief Project Description:

2.2. SAFETY AND HEALTH FRAMEWORK

Figure 2-1 summarizes the three layers of organizations/personnel that are typically involved safety and health plan compliance for waste composition projects. One unique aspect to the performance of a waste composition study is that the project is typically hosted by a permitted solid waste management facility. Such facilities are required to have detailed safety and health plans, accident prevention plans, accident reporting plans, emergency response plans, and other procedures and policies in place to minimize risks associated with handling municipal solid waste in an operating environment with noise, dust, heavy machinery, and other risks. For this reason, it is MSW Consultants' policy first and foremost to obtain, review, and comply with the safety and health framework that exists at the facility hosting the project. In the absence of the Field Supervisor due to sampling activities, the Crew Chief fulfills the associated responsibilities.

Figure 2-1 Safety and Health Plan Framework



Occasionally, procedural conflicts may arise between the host facility safety and health procedures and processes and MSW Consultants' site controls. In these instances, the requirement most protective of worker health and safety, the public, and property shall take precedence.

The remainder of this section identifies task organization and personnel responsibilities for the management and implementation of this SAHP. It also specifies the training and physical qualifications of employees performing the work. Accident reporting, recordkeeping, and emergency planning also are discussed in this section of the SAHP:

2.3. SUBCONTRACTORS

MSW Consultants does not subcontract for the performance of waste composition data collection, save for the use of temporary employment agencies to supply light industrial temporary laborers. Although these temporary staffing agencies may maintain corporate safety records and/or safety program statistics, such data is tracked only at the corporate level and is not considered in the pre-qualification of light industrial temporary staff to assist on waste composition data collection projects. MSW Consultants does not review safety training documents, safety programs or safety metrics from

SAFETY AND HEALTH PLAN

these agencies because MSW Consultants supplies this training and documentation, as described in the following section.

2.4. TRAINING REQUIREMENTS

2.4.1 MSW EMPLOYEES

MSW management and field supervisory personnel will be provided basic training on general health and safety, as well as receive first aid training provided by the U.S. Red Cross. Records pertaining to management and field supervisory personnel training will be kept as part of each employee's permanent employee records.

2.4.2 FACILITY-SPECIFIC TRAINING (EMPLOYEES AND SUBCONTRACTORS)

If required by the host facility, all MSW Consultant employees and subcontractors will participate in a training program provided by the host facility.

The following training will be provided by MSW Consultants Field Supervisor or Crew Chief staff at the outset of the project and prior to conducting any field operations. This training is intended to be provided verbally in the form of tailgate meetings or roundtable discussions with the field employees.

- ◆ Understanding the SAHP;
- ◆ Personal protective equipment and use;
- ◆ Physical, chemical, and biological hazards and prevention;
- ◆ Site access and control;
- ◆ Roles and responsibilities;
- ◆ Accident prevention and reporting; and
- ◆ Emergency procedures.

Upon completion of the training program, all participants will be required to sign the Plan Approval and Sign-off Form (Appendix A). Plan Approval and Sign-off forms will be kept for a minimum of three years.

2.5. CLIENT PERSONNEL AND VISITORS

Client personnel other than those already working at the host facility and other visitors must obtain clearance from both the host facility management and from the MSW Consultants Field Supervisor before obtaining access to controlled work areas. Visitors will receive a job-specific safety briefing. Visitors in areas requiring PPE must have the equivalent training and PPE as the on-site worker to gain entry. MSW Consultants is not responsible for distributing or obtaining PPE for visitors, or training visitors or client personnel on proper use of PPE, unless otherwise agreed to prior to the project.

2.6. PHYSICAL QUALIFICATION OF EMPLOYEES

All personnel associated with the sampling and handling of the materials collected from the field for this project will be trained in their safe handling. All personnel involved in the performance of physical

SAFETY AND HEALTH PLAN

work will be physically fit and demonstrate their ability to perform their duties. The MSW Consultants Field Supervisor can prohibit any person from performing work at the site should there be a question as to their fitness for duty.

As staffing reports for duty at the pre-determined location, MSW professional staff will utilize an infrared thermometer to detect the individual's temperature and assess the existence of any other symptoms. According to the Centers for Disease Control and Prevention (CDC), the following symptoms are the most common, and most likely appear 2-14 days after exposure:

- Fever
- Cough
- Shortness of breath

Any person reporting for work that demonstrates symptoms of COVID-19 will be sent home until they can be tested. Please do not report to work if you experience any of these symptoms at home.

2.7. ROLES AND RESPONSIBILITIES

2.7.1 CORPORATE SAFETY AND HEALTH MANAGERS

MSW Consultants principals Walt Davenport and John Culbertson are responsible for the health and safety of all MSW Consultants employees. As officers of the company, their role entails:

- ◆ Oversee maintenance and implementation of the MSW Consultants Safety and Health Program;
- ◆ Provide project personnel with technical guidance for conducting field work in a safe and healthful manner;
- ◆ Assist with preparation, or review and approval of project health and safety documents;
- ◆ Assign adequate levels of support;
- ◆ Interact with contracts personnel to verify that subcontractors are informed and can meet MSW Consultants health and safety requirements for this work;
- ◆ Conduct field inspections, as necessary, in accordance with MSW Consultants policies and procedures, and to verify that action plans are developed to correct any deficiencies; and
- ◆ Confirm adequate documentation of all of the above aspects of the safety program.

2.7.2 FIELD SUPERVISOR

The Field Supervisor will be assigned on a project by project basis and will be trained and knowledgeable in the MSW Consultants SAHP as well as the host facility health and safety requirements. This position will be required to:

- ◆ Administer the SAHP for the specific project and coordinate any amendments to the SAHP with the MSW Consultants Health and Safety Managers;
- ◆ Verify current certifications of individuals' fitness and training prior to authorizing access to areas where site control is established;
- ◆ Conduct emergency planning actions such as interfacing with emergency providers, assessing emergency supplies, assessing possible emergency needs;
- ◆ Verify availability of health and safety equipment on site in accordance with the SAHP;

SAFETY AND HEALTH PLAN

- ◆ Verify that copies of plans and regulations are available at the site;
- ◆ Conduct employee health and safety orientations prior to the start of field activities;
- ◆ Conduct pre-screening of staff at the start of each work shift
- ◆ Monitor field activities including ongoing practice of social distancing, PPE usage and disinfection and cleaning of work space, as appropriate;
- ◆ Establish and enforce site controls;
- ◆ Assist in independent health and safety site audits conducted by MSW Consultants Corporate Personnel, regulatory agencies, or the host solid waste management facility;
- ◆ Conduct accident investigations of injuries, illnesses, and near misses and to ensure the completion of associated documentation;
- ◆ Possess first aid training;
- ◆ Exercise “stop work authority” when an imminent hazard or potentially dangerous work practice exists; and
- ◆ Complete and submit recordkeeping forms mandated by the SAHP.

2.7.3 SUBCONTRACTORS

MSW Consultants has historically relied on temporary light-industrial staffing agencies to supply the sorting laborers needed to perform the physical sorting of solid wastes. These laborers are required to perform the following:

- ◆ Attend site-specific orientation and safety meetings when participating in field work;
- ◆ Read, understand, and sign the training verification form that states “I have read, understood, and agree to abide by these safety and health policies and procedures,” before working on site;
- ◆ Evaluate tasks to be performed and site-specific hazards; develop appropriate controls and supplement this SAHP, as required;
- ◆ Follow safe work procedures for this work that will address the specific hazards associated with the task to be performed for this work;
- ◆ Ensure that all staff agree to be scanned for body temperature and self-report any ongoing cough or breathing difficulty being encountered;
- ◆ Ensure that all employees are trained in the safe and proper use of all tools they may use;
- ◆ Ensure that all employees receive a safety orientation before beginning to work;
- ◆ Assure that all employees use all necessary personal protective equipment (PPE) and practice social distancing of at least 6 feet from other individuals; and
- ◆ Promptly correct any unsafe conditions and report any known COVID-19 exposure for the protection of all.

2.7.4 COMMUNICATIONS

MSW Consultants strives to promote timely and accurate communication to all employees (MSW Consultants or subcontractor). Dynamic and open communication, from the top down and the bottom up, is vital to MSW Consultants' success.

MSW Consultants maintains an open-door policy and strongly encourages employees to communicate their ideas, concerns and suggestions through their supervisors. Because safety is of utmost importance to MSW Consultants, all employees can report safety hazards anonymously and without fear for reprimand or reprisal.

2.8. ACCIDENT REPORTING

As soon as possible following an incident or emergency, the Field Supervisor, or his designee is to directly notify the MSW Consultants Corporate Safety and Health Manager, the host facility manager, the subcontractor contact (if applicable) and the client. The Field Supervisor should complete the Accident or Injury Report (Appendix B) and provide the following information:

- ◆ Field Supervisor's name;
- ◆ Task name and task number;
- ◆ Exact location of incident;
- ◆ Name and employer of victim(s);
- ◆ Nature and extent of injuries;
- ◆ If victim(s) was transported off site for medical treatment, then name and address of medical facility and name of treating physician; and
- ◆ Telephone number where the Field Supervisor can be contacted during next 24 hours.

2.9. EMERGENCY PLANNING

This section discusses the health and safety and emergency planning required for this project. If health and safety concerns arise during field activities, the following steps will be taken:

- ◆ Bring health and safety concerns to the attention of the host facility manager;
- ◆ If the host facility manager is unable to satisfactorily address concerns, bring the concerns to the attention of the MSW Consultants Corporate Safety and Health Manager;
- ◆ In the event of an incident or emergency, notify responsible personnel listed in this plan; and
- ◆ Discuss "stop work authority" for imminent danger situations.

2.10. POST-JOB SAFETY PERFORMANCE REVIEWS

At the conclusion of each job, the management team will review safety performance with field operations management employees and subcontractors (if applicable). This review will occur within two (2) weeks of the completion of each job.

SAFETY AND HEALTH PLAN

3. SANITATION

Waste composition field sorting events typically last for one or more weeks. Because they may be carried out in multiple locations—on the face of a landfill or within the confines of a transfer station or other waste management facility—, it may be necessary to consider providing specialty sanitary requirements at the job site.

3.1. DRINKING WATER

Drinking water for the field work will be brought to the site and stored outside of the work area. It will not be brought within the work area, nor will it be accessed by any worker in a non-emergency situation without the worker first undergoing the proper decontamination procedure, as described elsewhere in this plan.

3.2. TOILETS AND WASHING FACILITIES

If the host facility provides access to toilets, including washing facilities, within reasonable distance from the job site, such toilets will be used. If no such access is possible, portable toilet facilities, including hand washing capability, will be provided by MSW Consultants for field work. Portable toilet facilities will be located outside, but in close proximity to, the work area. Workers must first undergo decontamination before using portable toilet facilities.

MSW Consultants will also maintain anti-bacterial hand sanitizer and towelettes for use outside the work area.

3.3. WASTE DISPOSAL

To the extent wastes are generated by field operations, this waste will be disposed in the same manner as the removal of sorted samples.

3.4. VERMIN CONTROL

MSW Consultants will comply with the vermin control measures in place at the host facility. This typically consists of maintaining daily site clean-up efforts, and requires that un-sorted samples be completely contained for overnight storage.

4. MEDICAL AND FIRST AID REQUIREMENTS

This section discusses the first aid and medical requirements that are applicable for this work. Prior to start of work, arrangements shall be made for medical facilities and personnel to provide prompt attention to the injured and for consultation on occupational safety and health matters. Medical considerations include:

- ◆ An effective means of communication (hard-wired or cellular telephone, two-way radio, etc.) with 911 access or other emergency response source and transportation to effectively care for injured workers shall be provided. Communication devices shall be tested in the area of use to assure functionality.

- ◆ The telephone numbers and locations of physicians, hospitals, or ambulances shall be carried by the Field Supervisor at all times.

4.1. FIRST AID KITS

First aid kits will be stored at locations where field work will be performed or in vehicles used to transport workers to the field. The kits will contain standard first aid supplies, including, but not limited to bandages and treatment for minor abrasions and strains and will comply with the criteria contained in American National Standards Institute (ANSI) Z308.1 in the ratio of one for every 25 persons or less. Distilled water or portable saline solution bottles will be taken to the field for emergency eye wash purposes.

First-aid kits shall be easily accessible to all workers, and each item maintained sterile. The contents of first-aid kits shall be checked by the employer prior to their use and at least weekly when work is in progress to ensure that expended items are replaced.

4.2. FIRST AID STATIONS AND INFIRMARIES

There are no first aid stations or infirmaries provided for this work, other than an eyewash station or a full supply of portable eye-wash bottles provided at by the Field Supervisor. Other than minor first aid procedures, all injuries or exposures will be treated by emergency personnel at off-site facilities.

If a medical emergency occurs, the Field Supervisor assumes charge until an ambulance arrives or until the injured person is admitted to the emergency room. Site personnel will prevent further injury by taking the following actions:

- ◆ If properly trained (including blood borne pathogen training) and properly equipped with appropriate PPE, initiate first aid and CPR, if needed.
- ◆ Call ambulance and hospital, as appropriate.
- ◆ Determine whether decontamination will make injury worse. If yes, seek medical treatment immediately.
- ◆ Make certain the injured person is accompanied to the emergency room by at least one field team member with the same employer.

5. PERSONAL PROTECTIVE EQUIPMENT (PPE)

The purpose of personal protective clothing and equipment is to shield or isolate individuals from the hazards that may be encountered when engineering and other controls are not feasible or cannot provide adequate protection. Adherence to all prescribed controls is vital to minimize exposures. If a hazard is encountered, MSW Consultants will immediately conduct a Hazard Assessment (Appendix C), take corrective action and record the incident.

PPE ensembles for site activities are defined by the EPA and OSHA. Either MSW Consultants or the subcontractor will supply appropriate PPE for their staff at no cost to individual employees or subcontractor staff, as agreed prior to the field operations. PPE must conform to the requirements of this SAHP; therefore, employee-owned equipment is not allowed. Those not supplied with the proper PPE will not be allowed to work at the site. PPE will be inspected, tested, and used as required.

SAFETY AND HEALTH PLAN

Employees shall be physically able and medically determined qualified to use the personal protective and safety equipment that may be required in their job duties. Employers shall ensure users of personal protective and safety equipment are trained to know the following: when PPE, and what types of PPE are necessary; how to properly don, doff, adjust, and wear PPE; limitations of the PPE; and proper care, inspection, testing, maintenance, useful life, storage, and disposal of the PPE.

Each affected employee shall demonstrate an understanding of this training and the ability to use PPE properly before being allowed to perform work requiring the use of PPE. When the employer has reason to believe that any affected employee who has been trained does not have the understanding and skill required for the task, the employer shall assure the employee receives the necessary retraining to acquire the appropriate skills. Re-training will also be conducted when the site environment changes, or if the PPE is changed/upgraded.

Upon completion of the PPE training program, all participants will be required to sign the Plan Approval and Sign-off Form (Appendix A).

Personal protective and safety equipment shall be inspected and maintained in serviceable and sanitary condition as recommended by the manufacturer. Defective or damaged equipment shall not be used and shall be removed from the work site to prevent accidental use. Most PPE required for waste composition projects is single-use only, with the intent of being discarded at the end of the day. For re-usable PPE, before being stored or reissued to another person, equipment shall be cleaned, disinfected, inspected, and repaired.

In general, MSW Consultants will comply with the PPE requirements of the host solid waste management facility. Such requirements supersede those described in this SAHP. However, MSW Consultants will require the following minimum PPE regardless of the host facility requirements.

5.1. GLOVES

Gloves are required to be worn by every employee involved in the physical handling of waste, regardless of the requirements of the host facility. Municipal solid waste may contain materials that are sharp or chemically dangerous if contacted by skin. Appropriate gloves are critical to worker safety.

MSW Consultants has evaluated safety gloves available from the safety products industry. Based on extensive field and office testing, we have standardized on Reinforced nitrile gloves that are compliant with 21 CFR 177.2600. Our preferred glove is shown in Figure 5-1. While no glove will effectively prevent every puncture, this glove provides extremely high puncture resistance, as well as chemical protection for chemical processing, alkaline units at petroleum refineries, metal plating operations, haz-mat handling, haz-mat suits and for hazardous waste disposal. Although arguably overkill for handling municipal solid waste, we believe such precautions are appropriate.

Figure 5-1 MSW Consultants Preferred Glove



5.2. EYE PROTECTION

Eye protection will be worn by employees engaged in physical sorting of municipal solid waste. Eye protection equipment shall be distinctly marked to facilitate identification of the manufacturer. Every worker should know the location of the nearest eye wash station or the location of eye wash bottles prior to beginning work.

MSW Consultants has evaluated eye protection products available from the safety products industry. Based on extensive field and office testing, we have standardized our eye protection on the product shown in Figure 5-2. This product is compliant with ANSI Z87.1-1989, and features an optimal combination of protection, functionality, and comfort. The wraparound style has a hinge less frame system, a single lens design providing a continuous field of vision, and a dynamic shape that allows you to wear eyewear around your neck, on top of your head or over a hardhat. The gel temple sleeves and soft, secure gel nosepiece provide additional wearing comfort. A clip-on, breakaway retainer cord is included with every pair. The lens is constructed of impact-resistant polycarbonate lens filters out 99.9% of UV radiation, and includes a scratch-resistant coating.

Figure 5-2 MSW Consultants Preferred Eye Protection



5.3. RESPIRATORY PROTECTION

Full and half mask respirators requiring fit-testing and specialized training are not required for the performance of waste composition studies. This is because only dust and odors, and not harmful vapors and oxygen-deficient atmospheres, are encountered on these projects. Face masks or cloth face coverings will be provided to all staffing and should be worn when on the project site within 6 feet of another individual. N95 disposable masks will be offered to all employees and subcontractors, as available. MSW Consultants has evaluated disposable respiratory protection products available from the safety products industry. Based on field and office testing, we have standardized our respiratory protection on the product shown in Figure 5-3. This product is National Institute for Occupational Safety and Health (NIOSH) approved. It conforms to facial contours, and comes in individual packages for ease of distribution and sanitary storage.

Figure 5-3 MSW Consultants Preferred Respiratory Protection



5.4. PLASTIC FACE SHIELDS

Plastic face shields similar to what it seen in Figure 5-4 will be offered to be used in lieu of safety glasses.

Figure 5-4 Plastic Face Shield



5.5. FOOTWEAR

Heavy-duty work boots with leather uppers are the minimum foot protection required to perform waste composition analysis. Although steel toes are not required, they are preferred. Employees (or subcontractors) not wearing the minimum foot protection shall not be allowed to enter the work site.

5.6. PROTECTIVE SUITS

Although not required, MSW Consultants will provide and encourage that all workers wear aprons or coveralls for the duration of physical sorting of wastes. For warm weather sorts, aprons are generally preferable because they allow greater airflow and help keep workers from overheating. For cold weather sorts, coveralls are preferred because they add a layer of warmth as well as barrier protection. Figure 5-5 shows a standard Tyvek coverall that may be worn in colder weather sorting events. These coveralls are available in a wide range of sizes, and meet sizing requirements of ANSI/ISEA 101-1996.

Figure 5-5 Tyvek Coveralls



5.7. OTHER PPE

Although not required by MSW Consultants when performing waste composition analysis, many host solid waste management facilities may require the following PPE:

- ◆ Reflective vests;
- ◆ Hard hats; and
- ◆ Hearing protection.

MSW Consultants will conduct a Hazard Assessment (Appendix C) to further confirm all required PPE items and they will be provided by MSW Consultants (at no cost to the employee).

6. HAZARDOUS SUBSTANCES AND ENVIRONMENTS

The activities covered by this SAHP take place entirely at host facilities permitted to receive municipal solid wastes (MSW). MSW by definition does not contain hazardous or toxic substances in sufficient concentration to require extraordinary safety precautions. However, MSW does potentially contain trace quantities of chemical, biological, and physical hazards that may be encountered during the conduct of work. This SAHP is written to provide guidance on ways to eliminate or minimize exposure to these trace hazards, and the steps to take if an exposure occurs.

To ensure that the designated work areas are safe and hazard-free, MSW Consultants will work closely with the host facility. MSW Consultants will also perform an initial site inspection to establish a safe work area and may perform periodic inspections to evaluate workplace hazards (Appendix C). Each inspection will be signed by the designated inspector and kept for a minimum of three years.

6.1. HAZARDOUS SUBSTANCES

Municipal solid waste by definition may not contain hazardous waste, with the exception of Household Hazardous Wastes (HHW) from residential generators, or commercial generators that dispose of HHW-like products at the minimum levels. Nonetheless, employees performing waste composition analysis must have an awareness of the possibility of these materials, which may include:

- ◆ Medical wastes from residential generators (e.g., sharps), including wastes that may contain bloodborne pathogens;
- ◆ Household poisons;
- ◆ Flammable chemicals;
- ◆ Lead-based paints; and
- ◆ Reactive agents.

Radioactive, biologically active, explosive and other highly hazardous materials are prohibited from being disposed as municipal solid waste, and to the extent these items are found during a waste composition study all sorting activities will be immediately postponed and the host facility management notified for removal of these wastes and site remediation.

This SAHP covers a wide variety of hazards known or suspected to exist or that are inherent to the process of waste management activities; however, unforeseen hazards may be present in the performance of these tasks. Hazards not covered by this SAHP specifically will be assessed by the Field Supervisor for the appropriate control measures to maximize worker, environment, and public safety.

6.2. HARMFUL PLANTS, ANIMALS, AND INSECTS

Depending on the location of the waste composition analysis, it is possible that the potential exist to exposure to harmful plants, animals or insects. Poison ivy may be encountered on the periphery of some work areas, and could conceivably occur in the sample itself. It is identified as having dark green, somewhat shiny foliage with sets of three, pointed leaves. Protective clothing will be worn during the performance of field work. Outer garments can either be disposed or washed at the end of each day. Protective gloves will be worn. If encountered, do not touch or burn this plant. If exposure occurs, thoroughly wash the exposed area with soap and water within 10 minutes to remove the irritating oil.

Although a remote risk, outdoor work areas may be in areas where deer ticks live. Deer ticks can carry Lyme Disease. Evidence of exposure is the presence of a tic on the body or clothes. A small, red circular area will appear shortly after a bite. If exposed, contact a physician and save the offending tics, if possible, for analysis. Avoid dense woods and wear a hat and light-colored, protective clothing. Check body at the end of each field day for the presence of tics.

Mosquitoes are known carriers of the West Nile Virus and other diseases. For outdoor work areas, protective clothing, including long pants and shirts, will be worn to reduce the area of exposure.

There is a possibility for other harmful vermin to be present at the site, such as snakes. Level D Modified PPE requires that boots should be worn, as well as long pants, which will discourage exposure to snakes. Due caution should be exercised when performing field work.

6.3. INCLEMENT WEATHER AND ENVIRONMENTAL HAZARDS

Hazards presented by the natural work environment may include heat or cold stress, and inclement weather. When there are warnings or indications of impending severe weather (heavy rains, damaging winds, tornados, hurricanes, floods, lightning, etc.), weather conditions shall be monitored and appropriate precautions taken to protect personnel and property from the effects of the severe

SAFETY AND HEALTH PLAN

weather. Table 6-1 outlines exposure control methods for working in extreme temperatures and summarizes symptoms and treatment procedures for heat and cold stress.

Table 6-1 Symptoms and Treatment of Heat and Cold Stress

Conditions	Symptoms	Treatment
Heat stroke	Red, hot, dry skin; no perspiration; dizziness; confusion; rapid breathing and pulse; and high body temperature.	This is a MEDICAL EMERGENCY! Cool victim rapidly by soaking in cool (not cold) water. Loosen restrictive clothing. Get medical attention immediately!
Heat exhaustion	Pale, clammy, moist skin; shallow breathing; profuse sweating; weakness; normal temperature; headache; dizziness; and vomiting.	Move victim to a cool, air-conditioned area. Loosen clothing, place head in low position. Have victim drink cool (not cold) water.
Frostbite	Blanched, white, waxy skin, but resilient tissue; tissue cold and pale.	Move victim to a warm area. Warm area quickly in warm (not hot) water. Do not break any blisters. Elevate the injured area and get medical attention.
Hypothermia	Shivering, apathy, sleepiness; rapid drop in body temperature; glassy stare; slow pulse; and slow respiration.	Move victim to a warm area. Have victim drink warm fluids - not coffee or alcohol. Get medical attention.

In the event of adverse weather conditions, the Field Supervisor will evaluate whether work can continue without compromising the health and safety of site personnel. The Field Supervisor will direct the implementation of precautions necessary to ensure the health and safety of site personnel. A lightning watch will go into effect 30 minutes prior to thunderstorms being within a five nautical mile radius of an activity. During the watch, operations or activities may continue, however all personnel must be prepared to implement warning procedures without delay. Workers must be alert for any lightning activity, to include audible thunder, and advise supervisory personnel of any observations.

6.4. DECONTAMINATION

Decontamination protects workers, the public, and the environment by limiting exposure to harmful substances and by preventing the spread of contamination. The Field Supervisor will oversee personnel and equipment decontamination to determine its effectiveness, and take corrective actions to rectify any deficiencies. Table 6-2 presents the decontamination procedures that will be followed for personnel and equipment. Subcontractors are responsible for decontaminating their own equipment and personnel according to these procedures.

MSW Consultants will also maintain hand sanitizers that have been prepared as suggested by the US Centers for Disease Control and Prevention (CDC) for cleaning and disinfecting in the presence of confirmed or suspected exposure to the coronavirus. For more information, please see the Coronavirus Disease 2019 CDC website at: <https://www.cdc.gov/coronavirus/2019-nCoV/index.html>.

Table 6-2 Key Decontamination Procedures

Item	Decontamination Procedure
Equipment Mobilization, Demobilization and Carpooling	Workers that mobilize equipment and travel to and from a work site together should wear masks; wash hands prior to and after the ride; create as much physical distance between each other as possible and avoid physical contact; keep disinfectant wipes or a damp soapy cloth, tissues and hand sanitizer in the vehicle; cover mouth and nose with a tissue or sleeve in the event of coughing or sneezing; avoid touching eyes, nose or mouth; and wipe down the interior of the vehicle prior to and after the ride.
Sampling Table, Bins, and Tools	Pressure wash at the conclusion of the waste composition study in an area with leachate collection.
Personnel – Mid day breaks	PPE shall be removed while the worker is in the work area. Employees shall wash hands and forearms in the washing facility supplied for the project. Hand sanitizer and/or wipes will be provided.
Personnel – End of Day	Hard hats, vests and eye protection shall be wiped down with disinfectant wipes or damp soapy cloth and returned to the Field Supervisor for inspection and cleaning. Neoprene gloves shall be removed, inspected for tears and chemical damage, and if still in safe working condition, stored in the work area. Damaged gloves shall be replaced for subsequent work days. Tyvek suits, face masks/respirators, and ear plugs shall be discarded as solid waste. Employees shall wash hands and forearms in the washing facility supplied for the project or use provided disinfectant wipes, spray and paper towels.

6.4.1 ADDITIONAL PROCEDURES FOR CLEANING AND DISINFECTING JOB-SITE SURFACES

- ◆ Wear disposable gloves when cleaning and disinfecting surfaces. Gloves should be discarded after each cleaning. If reusable gloves are used, those gloves should be dedicated for cleaning and disinfection of surfaces for COVID-19 and should not be used for other purposes. Consult the manufacturer’s instructions for cleaning and disinfection products used. Clean hands immediately after gloves are removed.
- ◆ If surfaces are dirty, they should be cleaned using a detergent or soap and water prior to disinfection.
- ◆ For disinfection, diluted household bleach solutions, alcohol solutions with at least 70% alcohol, and most common EPA-registered household disinfectants should be effective.
- ◆ Diluted household bleach solutions can be used if appropriate for the surface. Follow manufacturer’s instructions for application and proper ventilation. Check to ensure the product is not past its expiration date. Never mix household bleach with ammonia or any other cleanser.

SAFETY AND HEALTH PLAN

Unexpired household bleach will be effective against coronaviruses when properly diluted. (1-1/3 cups bleach per gallon of water)

6.4.2 GUIDANCE FOR DAILY HOME LAUNDERING OF WORK SITE CLOTHING

- ◆ If no gloves are used when handling dirty laundry, be sure to wash hands afterwards.
- ◆ If possible, do not shake dirty laundry. This will minimize the possibility of dispersing germs and contaminants through the air.
- ◆ Launder items as appropriate in accordance with the manufacturer's instructions. If possible, launder items using the warmest appropriate water setting for the items and dry items completely.

6.5. PERSONNEL DECONTAMINATION

All personnel exiting the sampling area will follow decontamination procedures. Under no circumstances (except emergency evacuation) will personnel be allowed to leave the work area before decontamination. The Field Supervisor may approve simplification of the procedures in the field when a determination has been made that decontamination procedures are unnecessary.

Hand hygiene and other preventive measures shall be practiced as follows:

- ◆ You should clean your hands often, including immediately after removing gloves, by washing hands with soap and water for 20 seconds. If soap and water are not available and hands are not visibly dirty, an alcohol-based hand sanitizer that contains at least 60% alcohol may be used. However, if hands are visibly dirty, always wash hands with soap and water.
- ◆ All workers should follow normal preventive actions while at work and home including recommended hand hygiene and avoiding touching eyes, nose, or mouth with unwashed hands.
- ◆ Additional key times to clean hands include:
 - After blowing one's nose, coughing, or sneezing;
 - After using the restroom;
 - Before eating or preparing food;
 - After contact with animals or pets; and
 - Before and after providing routine care for another person who needs assistance (e.g. a child.)

7. MATERIAL HANDLING

Per OSHA, workers and employers should manage municipal (e.g., household, business) solid waste and recyclables with potential or known COVID-19 contamination like any other non-contaminated municipal waste and recyclables.

Use typical engineering and administrative controls, safe work practices, and PPE, such as puncture-resistant gloves and face and eye protection, to prevent worker exposure to the waste streams (or types of wastes), including any contaminants in the materials they manage. Such measures can help protect workers from sharps and other items that can cause injuries or exposures to infectious materials. PPE and proper decontamination have been described above.

Although waste composition projects do not require extensive handling of heavy material, there is significant lifting and carrying that must be performed to complete the data collection. This section describes considerations in handling materials during the waste composition study.

7.1. LIFTING AND CARRYING

Employees shall be trained in and shall use safe lifting techniques. When lifting:

- ◆ Reaching out to lift an object fights against gravity, and increases strain on the lower back. Stand close to the load to be lifted and spread your feet for balance.
- ◆ Be certain the weight being lifted is within your capabilities. Ask for assistance if needed.
- ◆ Bend your knees and keep your spine straight. Grasp the object to be lifted and keep it close to your body.
- ◆ Using your leg muscles, straighten your knees and stand.

When carrying:

- ◆ Always keep the object you are carrying close to your body.
- ◆ When changing directions, shift your feet. Don't twist the upper body.
- ◆ Try to avoid changing your grip while carrying the load.
- ◆ After reaching your destination, keep the object close to your body, keep the spine straight, and slowly bend the knees as you lower the object to the floor.

7.2. TEMPORARY MATERIAL AND EQUIPMENT STORAGE

To the extent it is necessary to store sampled wastes until future sorting day and time, the entire sample shall be contained by either temporary or permanent means. Permanent storage is preferred in containers with lids. In some instances, tarping of sampled material is acceptable, provided the tarp can fully contain the sampled waste and be weighted down to prevent removal by vermin or from winds.

Work site equipment shall be stacked, consolidated, and placed at ground level so that it is stable and secured against sliding or collapse.

7.3. HOUSEKEEPING

Scrap, trash, and other wastes shall be placed in designated containers. Work areas shall be cleaned up as the job progresses. Cords and hoses shall be routed in a manner that will present no tripping hazard - preferably overhead. At a minimum, all tools, and equipment shall be stored in a stable position (tied, stacked, or chocked) to prevent rolling or falling. Tools and equipment will preferably be removed from the work site for secure storage in a vehicle overnight. A safe access way shall be maintained to all work areas and emergency exits.

SAFETY AND HEALTH PLAN

7.4. MATERIAL DISPOSAL

Waste generated onsite from field activities includes the sorted waste samples, PPE discards, and field trash. These wastes will be managed as non-hazardous, solid waste, and will be placed in the same receptacle being used to remove sorted waste samples.

Any HHW that is found in the samples wastes shall be stored and disposed according to host facility HHW collection policies. If no such policies exist, the HHW will be disposed with the remaining solid wastes.

At the request of the host facility, recyclable materials may be set aside for recovery by the host facility.

8. SITE CONTROL

Effective site control procedures will reduce the potential safety and health risks to the workers on site. Site control includes the following safe work practices:

- ◆ Limiting work area access to essential personnel, both during work hours and off hours;
- ◆ Establishing work zones within the sampling and sorting areas, and restricting personnel entering work zones;
- ◆ Establishing decontamination procedures for personnel and equipment as described above; and
- ◆ Assuring that personnel may be accurately and quickly located and evacuated during an emergency.

At no time will new substances, procedures or processes be introduced into the work site without prior evaluation and approval by MSW Consultants management.

As a general site control, alcoholic beverages, food, cigarettes, and other consumable products are prohibited in work areas at all times.

8.1. SAMPLING AREA CONTROLS

An area at the host facility will be set aside for the oversight of vehicle load tipping and sampling of the tipped load. The sampling work area shall be controlled by:

- ◆ Delineating boundaries for the tipping of targeted loads of waste;
- ◆ Prohibiting entry into these boundaries by non-targeted truckloads;
- ◆ Providing for the safe queuing of material transport hoppers out of the way of collection vehicles and waste handling mobile equipment such as loaders or compactors; and
- ◆ Providing a storage location for a loader or skid steer that may be needed to transport samples.

Only the Field Supervisor or a trained sampling manager may enter into the sampling work area during the course of the project.

8.2. SORTING AREA CONTROLS

An area at the host facility will be set aside for the performance of sorting and weighing sampled wastes. The sorting work area shall be controlled by:

- ◆ Setting aside a 20 foot by 20-foot space where the sort table and bins can be positioned;

SAFETY AND HEALTH PLAN

- ◆ Providing additional space for queuing samples;
- ◆ Maintaining a consistent site configuration so that employees know the proper position of all equipment and materials; and
- ◆ Being established out of the way of any heavy machinery or equipment that may be in operation within the facility boundaries.

No personnel will enter or work in delineated work zones without proper training or an escort.

This page intentionally left blank.

SAFETY AND HEALTH PLAN

APPENDIX A

PLAN APPROVAL AND SIGN OFF

This page intentionally left blank.

APPENDIX A – PLAN APPROVAL AND SIGN-OFF

This Safety and Health Plan has been written for the exclusive use of MSW Consultants, its employees, and subcontractors. Although intended to be a generic plan that applies broadly to waste composition projects, it may require amendment for certain specific projects or facilities. Subcontractors are required to supplement this plan, as needed, to address specific tasks (and associated hazards) they may be performing.

The following signatures verify that the undersigned has either reviewed the written Plan or else has received training on relevant components of the Plan.

Project: _____

Location: _____

Concurrence by: _____ Date: _____

MSW Consultants Field Supervisor

Crew Signoff:

“I have read, understood, and agree to abide by relevant sections of this SAHP.”

Signature: _____ Date: _____

Organization: _____

Signature: _____ Date: _____

Organization: _____

Signature: _____ Date: _____

Organization: _____

Signature: _____ Date: _____

Organization: _____

APPENDIX A - PLAN APPROVAL AND SIGN OFF

Project: _____ Location: _____

Signature: _____ Date: _____

Organization: _____

Signature: _____ Date: _____

Organization: _____

Signature: _____ Date: _____

Organization: _____

Signature: _____ Date: _____

Organization: _____

Signature: _____ Date: _____

Organization: _____

Signature: _____ Date: _____

Organization: _____

Signature: _____ Date: _____

Organization: _____

Signature: _____ Date: _____

Organization: _____

SAFETY AND HEALTH PLAN

APPENDIX B

ACCIDENT OR INJURY REPORT

This page intentionally left blank.



APPENDIX B
ACCIDENT OR INJURY REPORT: Confidential

Date/Time Report Initiated: _____

Information in this report is to be used for the prevention of accidents and is not intended as a basis for injury claims. In counting time lost, start with the first full day or shift lost after date of injury and do not include weekends and holidays.

GENERAL INFORMATION:

Type of Accident:
Location:
Weather Conditions:
Temperature:
Wind:
Date and Time of accident or injury:

INJURED PERSONNEL:

Name:		
Age:	Title:	Occupation:
Employer if Different from MSW Consultants:		
How Long Employed:	Remarks:	

NATURE AND PLACE OF INJURY:

Exact place where injury occurred:
If lost time/restricted duty resulted, date employee started losing time/restricted duty:
Did injury result in death or probable permanent disability?
Return to work date/full duty: (Estimated)
Date of death:
Calendar days lost time (Estimated):
Describe accident/ injury:

IF INJURED PERSON IS EMPLOYED BY ANOTHER FIRM:

Date and Time injured personnel's employer was contacted:
Name of employer contact person:

DAMAGED PROPERTY:

Name:		
Age:	Title:	Occupation:
Employer if Different from MSW Consultants:		
How Long Employed:	Remarks:	

NATURE AND PLACE OF PROPERTY DAMAGE:

Exact place where damage occurred (include address):
Property owner:
Property owner contact name:
Property owner contact phone:
Property owner contact email:
Date and time reported to Property owner:
Describe property damage:

Supervisor Signature: _____

Date: _____

SAFETY AND HEALTH PLAN

APPENDIX C

HAZARD ASSESSMENT AND CORRECTION RECORD

This page intentionally left blank.

HAZARD ASSESSMENT and CORRECTION RECORD



Date/Time of Inspection: _____

GENERAL INFORMATION:

Person Conducting the Inspection:
Project Name:
Location:

MSW Consultants will perform an initial work site inspection to establish a safe work area. MSW Consultants will work closely with the Host Facility to ensure that the designated work area is hazard-free and the documented safety procedures are followed. MSW Consultants and the Host Facility may perform periodic inspections to identify and evaluate workplace hazards.

Check One: Initial Inspection Periodic Inspection

WORK SITE INSPECTION:

UNSAFE CONDITION or WORK PRACTICE:

CORRECTIVE ACTION TAKEN:

Inspector's Signature: _____

This page intentionally left blank.





APPENDIX B

Questionnaire Forms

This page intentionally left blank.

Vermont DEC – Questionnaire for Food Scrap Generators

Vermont's Universal Recycling law (Act 148) fully banned food scraps from disposal in the trash. As part of the 2023 VT statewide Waste Characterization Study, we are conducting this questionnaire to generate estimates of hard-to-track diversion of food scraps from the waste stream and learn where the materials end up. Please help us by providing your food scrap management practices in the fillable form below.

Facility Information	Contact Information
Facility Name _____	Contact Name _____
Address _____	Title _____
City _____ St _____ Zip _____	Phone _____
	Email _____
How many company/facility locations are you reporting for? _____	
Enter the estimated amount food waste you diverted from the landfill in 2022: _____	Otherwise, please fill out the rest of the questionnaire
If you did not divert any food waste in 2022, check this box. _____ The questionnaire is complete.	

Food Rescue/Donations: Please tell us about any still-edible food you are able to recover and donate.

Estimate the percentage of your food that was rescued in 2022 (e.g. sent to food donation groups) _____%

Estimate the approximate pounds of food rescued in 2022 _____ Lbs.

Where do you send your rescued food?

Check here if you do not know the organization.

Organization Name

Organization Location

City _____ St _____

If you use a Vermont waste/food scrap hauler to handle your food scraps, please list their name and do not complete the rest of this form unless you also use direct processors. _____

For Source Separated Food Scraps: Please tell us about the fraction of your food scraps that are very clean, are not contained in packaging, and are generally free of contamination.

Estimate the percentage of your food scraps that are source separated _____%

Estimate the approximate pounds of source separated food waste in 2022 _____ Lbs.

Where do you send your source separated food scraps?

Check here if you do not know the facility.

Type of Facility

Facility Name

Facility Location

City _____ St _____

For Packaged Food Scraps (or if you mix Source Separated and Packaged Food Waste): Please tell us about the fraction of your food scraps that are contained in packaging and need depackaging to free the food for processing.

Estimate the percentage of your food scraps that are packaged _____%

Estimate the approximate pounds of packaged food waste in 2022 _____ Lbs

Where do you send your packaged food scraps?

Check here if you do not know the facility.

Type of Facility

Facility Name

Facility Location

City _____ St _____

Non-Disclosure Request

The information provided is confidential. Check one: Yes No

MSW Consultants (MSW) will hold confidential any information and data provided to us which you specify as confidential, as part of the 2023 Waste Composition Study that MSW is conducting for the Vermont Department of Environmental Conservation (DEC). The purpose of the study is to develop reasonable and professional estimates of the quantity of all food scrap managed throughout the state, and to ensure no double counting of material occurs. Data provided to MSW will be aggregated with all other material quantities reported to develop a single annual quantity (in tons) of food scrap managed which will be reported to Vermont DEC.

If you have any questions about this form, please call the third-party consulting firm, MSW Consultants, at (800)-679-9200 ext. 2 or e-mail survey@mswconsultants.com. If you have questions about the project in general, please contact Emma Stuhl at the Vermont Department of Environmental Conservation Solid Waste Program at (802)-622-4325 or emma.stuhl@vermont.gov.

Vermont DEC – Questionnaire for Food Scrap Transporters

Vermont's Universal Recycling law (Act 148) fully banned food scraps from disposal in the trash. As part of the 2023 VT statewide Waste Characterization Study, we are conducting this questionnaire to generate estimates of hard-to-track diversion of food scraps from the waste stream and learn where the materials end up. Please help us by providing your food scrap management practices in the fillable form below.

Company Information	Contact Information																																
Name _____	Contact Name _____																																
Address _____	Title _____																																
City _____ St _____ Zip _____	Phone _____																																
	Email _____																																
<p>Enter the annual estimated Vermont generated (e.g. collected in Vermont) food waste (including residential curbside and drop-off, commercial, and pre-processed slurry) you transported in 2022. _____ tons</p> <p>If you did not transport any food waste in Vermont in 2022, check this box. <input type="checkbox"/> The questionnaire is complete</p> <p>If you collect and transport Vermont food waste that is still in its original packaging and that is brought to a depackaging machine, what percentage of the food waste you transported was:</p> <p>Packaged food waste or food waste mixed with packaged food waste? _____%</p> <p>Source separated food waste that did not contain food waste still in its original packaging _____%</p>																																	
<p>List the top three facilities where you delivered Vermont source separated food waste (if you didn't transport source separated food waste, leave these boxes blank):</p> <table style="width: 100%; border-collapse: collapse;"> <thead> <tr> <th style="width: 10%;">Estimated Tons</th> <th style="width: 25%;">Type of Facility</th> <th style="width: 40%;">Facility Name</th> <th style="width: 25%;">Facility Location</th> </tr> </thead> <tbody> <tr> <td>_____</td> <td>_____</td> <td>_____</td> <td>City _____ St _____</td> </tr> <tr> <td>_____</td> <td>_____</td> <td>_____</td> <td>City _____ St _____</td> </tr> <tr> <td>_____</td> <td>_____</td> <td>_____</td> <td>City _____ St _____</td> </tr> </tbody> </table> <p>List the top three facilities where you delivered Vermont packaged food waste (if you didn't transport packaged or mixed food waste, leave these boxes blank):</p> <table style="width: 100%; border-collapse: collapse;"> <thead> <tr> <th style="width: 10%;">Estimated Tons</th> <th style="width: 25%;">Type of Facility</th> <th style="width: 40%;">Facility Name</th> <th style="width: 25%;">Facility Location</th> </tr> </thead> <tbody> <tr> <td>_____</td> <td>_____</td> <td>_____</td> <td>City _____ St _____</td> </tr> <tr> <td>_____</td> <td>_____</td> <td>_____</td> <td>City _____ St _____</td> </tr> <tr> <td>_____</td> <td>_____</td> <td>_____</td> <td>City _____ St _____</td> </tr> </tbody> </table>		Estimated Tons	Type of Facility	Facility Name	Facility Location	_____	_____	_____	City _____ St _____	_____	_____	_____	City _____ St _____	_____	_____	_____	City _____ St _____	Estimated Tons	Type of Facility	Facility Name	Facility Location	_____	_____	_____	City _____ St _____	_____	_____	_____	City _____ St _____	_____	_____	_____	City _____ St _____
Estimated Tons	Type of Facility	Facility Name	Facility Location																														
_____	_____	_____	City _____ St _____																														
_____	_____	_____	City _____ St _____																														
_____	_____	_____	City _____ St _____																														
Estimated Tons	Type of Facility	Facility Name	Facility Location																														
_____	_____	_____	City _____ St _____																														
_____	_____	_____	City _____ St _____																														
_____	_____	_____	City _____ St _____																														
<p>If you transported any out-of-state food waste in 2022 into Vermont please indicate the estimated amount, type of food waste using the drop down arrow in the box, and list what facility and its location.</p> <table style="width: 100%; border-collapse: collapse;"> <thead> <tr> <th style="width: 10%;">Estimated Tons</th> <th style="width: 25%;">Type of Facility</th> <th style="width: 40%;">Facility Name</th> <th style="width: 25%;">Facility Location</th> </tr> </thead> <tbody> <tr> <td>_____</td> <td>_____</td> <td>_____</td> <td>City _____ St _____</td> </tr> <tr> <td>_____</td> <td>_____</td> <td>_____</td> <td>City _____ St _____</td> </tr> <tr> <td>_____</td> <td>_____</td> <td>_____</td> <td>City _____ St _____</td> </tr> </tbody> </table>		Estimated Tons	Type of Facility	Facility Name	Facility Location	_____	_____	_____	City _____ St _____	_____	_____	_____	City _____ St _____	_____	_____	_____	City _____ St _____																
Estimated Tons	Type of Facility	Facility Name	Facility Location																														
_____	_____	_____	City _____ St _____																														
_____	_____	_____	City _____ St _____																														
_____	_____	_____	City _____ St _____																														

Please continue the questionnaire on the next page

Vermont DEC – Questionnaire for Food Scrap Transporters (continued)

Non-Disclosure Request

The information provided is confidential. Check one: Yes No

MSW Consultants (MSW) will hold confidential any information and data provided to us which you specify as confidential, as part of the 2023 Waste Composition Study that MSW is conducting for the Vermont Department of Environmental Conservation (DEC). The purpose of the study is to develop reasonable and professional estimates of the quantity of all food scrap managed throughout the state, and to ensure no double counting of material occurs. Data provided to MSW will be aggregated with all other material quantities reported to develop a single annual quantity (in tons) of food scrap managed which will be reported to Vermont DEC.

If you have any questions about this form, please call the third-party consulting firm, MSW Consultants, at (800) 679-9200 ext. 2 or e-mail survey@mswconsultants.com. If you have questions about the project in general, please contact Emma Stuhl at the Vermont Department of Environmental Conservation Solid Waste Program at (802) 622-4325 or emma.stuhl@vermont.gov.

Vermont DEC – Questionnaire for Direct-to-Broker

Vermont's Universal Recycling law (Act 148) fully banned food scraps from disposal in the trash. As part of the 2023 VT statewide Waste Characterization Study, we are conducting this questionnaire to generate estimates of hard-to-track diversion of recyclable material from the waste stream and learn where the materials end up. Please help us by providing your recyclable material management practices in the fillable form below.

Facility Information	Contact Information
Facility Name _____	Contact Name _____
Address _____	Title _____
City _____ St _____ Zip _____	Phone _____
	Email _____
Company Type	
Supermarket or retail store	Recycling Processor
Self-Brokering Recyclables Generator	Broker/Other _____
How many company/facility locations are you reporting for? _____	
If you use a Vermont waste/recycling hauler to handle your recyclables, please list their name below and do not complete the rest of this form. _____	

Materials Recycled (Between January 1 and December 31, 2022)

Material Type ¹	Annual Tons Recycled (2022)	Please list the company or location where each material is sent for Recycling, Processing, or End Use ²	Percent Commercial	Percent Residential	Approx. percent of material originating from Vermont ONLY ³
Cardboard					
Other Paper Fibers					
MGP Containers					
Plastic Film					
Scrap Metal					

1. Materials Listed: Corrugated Cardboard; Other Paper Fibers; Metal/Glass/Plastic Containers; Plastic Film/Shrink Wrap/Retail Bags; Scrap Metal. Please list any additional recyclable materials in the empty boxes.
2. This information ensures that material is not double counted due to an end user's participation in our survey.
3. If you handle material generated outside of Vermont, estimate the percent of material generated in Vermont only.

Non-Disclosure Request

The information provided is confidential. Check one: **Yes** **No**

MSW Consultants (MSW) will hold confidential any information and data provided to us which you specify as confidential, as part of the 2023 Waste Composition Study that MSW is conducting for the Vermont Department of Environmental Conservation (DEC). The purpose of the study is to develop reasonable and professional estimates of the quantity of all recyclable materials throughout the state, and to ensure no double counting of material occurs. Data provided to MSW will be aggregated with all other material quantities reported to develop a single annual quantity (in tons) of recyclable materials managed which will be reported to Vermont DEC.

If you have any questions about this form, please call the third-party consulting firm, MSW Consultants, at (800) 679-9200 ext. 2 or e-mail survey@mswconsultants.com. If you have questions about the project in general, please contact Emma Stuhl at the Vermont Department of Environmental Conservation Solid Waste Program at (802) 622-4325 or emma.stuhl@vermont.gov.

APPENDIX C

UNH Survey Center Residential Food Scrap Questionnaire Report

This page is intentionally left blank.



University of
New Hampshire

The Survey Center

A photograph showing two people, a man and a woman, sorting food scraps into yellow 'BRUTE' bins on the back of a truck. The bins are stacked and filled with organic waste. The background shows a rural landscape with trees and a field under a cloudy sky.

Vermont Department of Environmental Conservation 2023 Residential Food Scraps Questionnaire

Prepared by:

Zachary S. Azem, M.A.
Sean P. McKinley, M.A.

The Survey Center
University of New Hampshire
November, 2023

The University of New Hampshire
Survey Center

The UNH Survey Center is an independent, non-partisan academic survey research organization and division of the UNH College of Liberal Arts.

The Survey Center conducts telephone, mail, web, and intercept surveys, as well as focus groups and other qualitative research for university researchers, government agencies, public non-profit organizations, private businesses and media clients.

Our senior staff have over 50 years experience in designing and conducting custom research on a broad range of political, social, health care, and other public policy issues.

Dr. Andrew E. Smith, Director
UNH Survey Center
9 Madbury Road, Suite 402
Durham, New Hampshire 03824
603-862-2226
Andrew.Smith@unh.edu

Table of Contents

Executive Summary	1
Key Findings	1
Demographics	2
Vermont Universal Recycling Law	5
Statements About Composting	6
Composting Behavior	13
Technical Report	35
Appendix A: Detailed Tabular Results	37
Appendix B: Open-ended Responses	68
Appendix C: Questionnaire	96

Executive Summary

The University of New Hampshire Survey Center with collaboration from MSW Consultants and DSM Environmental Services fielded a questionnaire on behalf of the Vermont Department of Environmental Conservation. The study was conducted to better understand the attitudes and practices of Vermonters regarding household composting of food scraps. Nine hundred fifty-three (953) Green Mountain State Panel members completed the questionnaire online between September 14 and September 18. The response rate was 33% and the margin of sampling error is +/- 3.2 percent.

The following figures display overall results, detailed tabular results may be found in Appendix A, Appendix B contains open-ended responses, and Appendix C contains the questionnaire. Due to rounding, percentages may not add to 100%.

Key Findings

More than half of Vermonters feel that Vermont residents are very informed or informed about the Vermont Universal Recycling Law, which banned food scraps and other organic waste that decomposes from being disposed of in regular trash and landfills.

Most Vermonters think it is true that composting is good for the environment and that Vermonters should participate in composting, though relatively few say that they don't have the space to compost. However, about four in ten Vermonters don't feel composting is easy to do and feel that composting smells bad and attracts pests. Men and those with lower levels of education tend to be most antagonistic towards composting, while a majority of those who rent their home or live in an apartment or duplex say they don't have the space for composting.

One in five Vermonters, particularly those with the lowest incomes and those who live in apartments or duplexes, say that they do not compost or feed their food waste to animals at all. Composting by setting food waste aside in one's own compost pile is by far the most common method for people to manage their food waste. Vermonters who compost estimate that nearly 60% of their food waste is dealt with this way, followed by food scraps being picked up by a waste hauler or being dropped off at a transfer station or other collection point specifically for composting. Among those who do compost, more than four in ten say they also throw food waste in the regular trash, but most say that less than a quarter of their food waste is disposed of in this manner.

Overall, state residents estimate that more than three-quarters of their food waste is composted throughout the year, with composting rates marginally higher in the summer and marginally lower in the winter.

The setting of one's home has a clear influence on the method by which Vermonters manage their food waste: those who rent, live in more urban areas, and do not live in detached single-family homes are far less likely to use their own compost pile or composter, and are considerably more likely to have their food waste picked up by a waste hauler.

Among those who do compost or set aside food scraps for animals, a plurality use a container about the size of a gallon of milk, and a majority empty the container between one and three times per week. A majority say that the container on average is completely or almost full when it is emptied, while only one in six typically empty their container when it is only half full or less.

Using results from this survey data, it is estimated that the average household in Vermont composts about 12 pounds per week, which amounts to about 626 pounds per year.

Demographics

In order to ensure results that are representative of the state of Vermont, data were weighted by respondent gender, age, education, and region of the state to targets from the most recent American Community Survey (ACS) conducted by the U.S. Census Bureau.

Figure 1: Weighted Demographic Questions and ACS Estimates

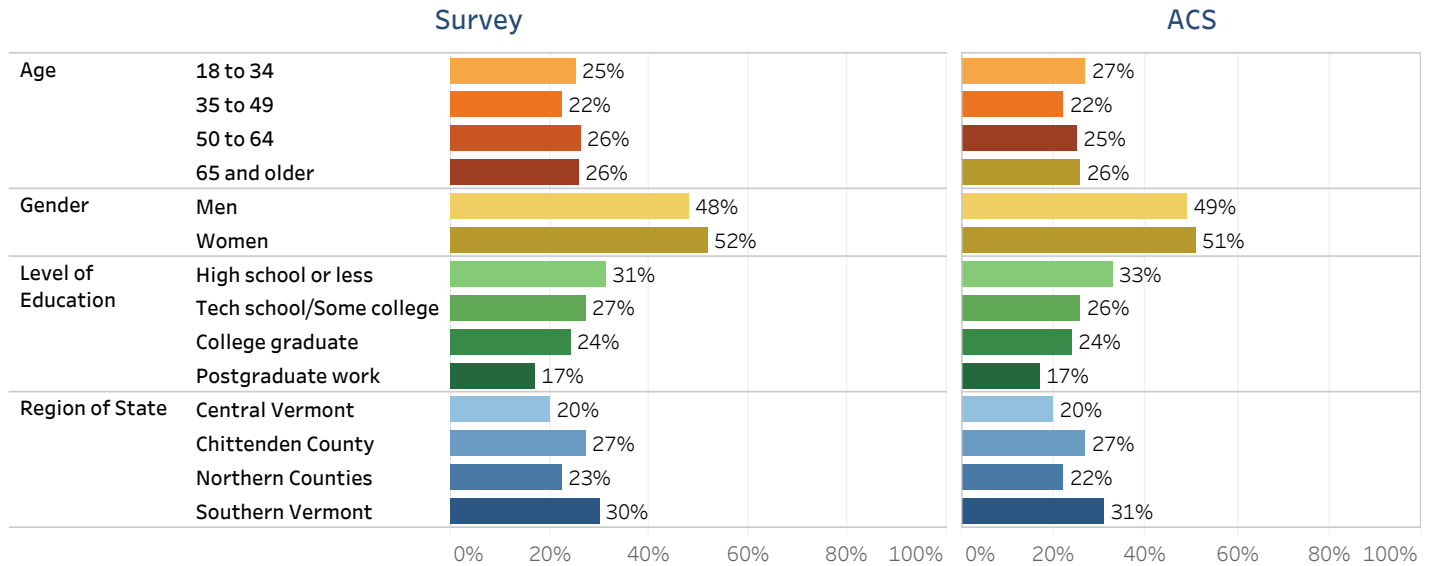

Just over a quarter of respondents (27%) say they have children in their household and about half of respondents (49%) have a household income under \$75,000. Seventy-eight percent of respondents say they own their home and 85% have at least two people in their household. When comparing to latest ACS estimates for these demographic variables, the data is largely comparable. Those in who live in a single person household are underrepresented compared to the ACS estimates.

Figure 2: Other Demographic Questions and ACS Estimates

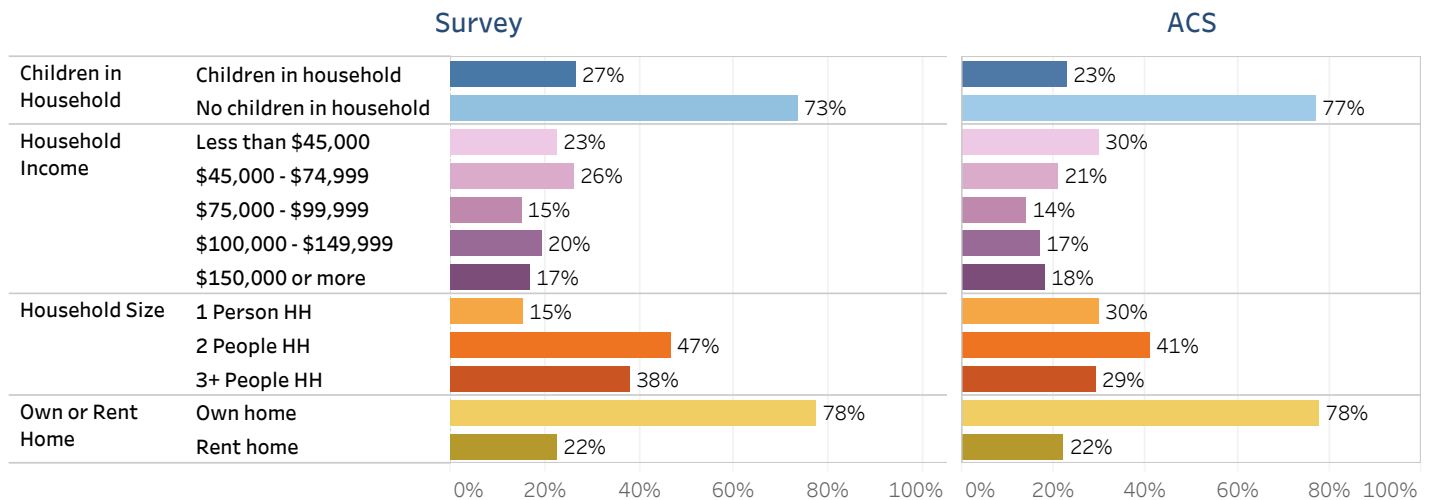

Half of respondents (52%) are employed full-time, 11% are employed part-time, 32% are retired or not working, 5% are unemployed, and less than 1% are students.

Figure 3: Employment Status

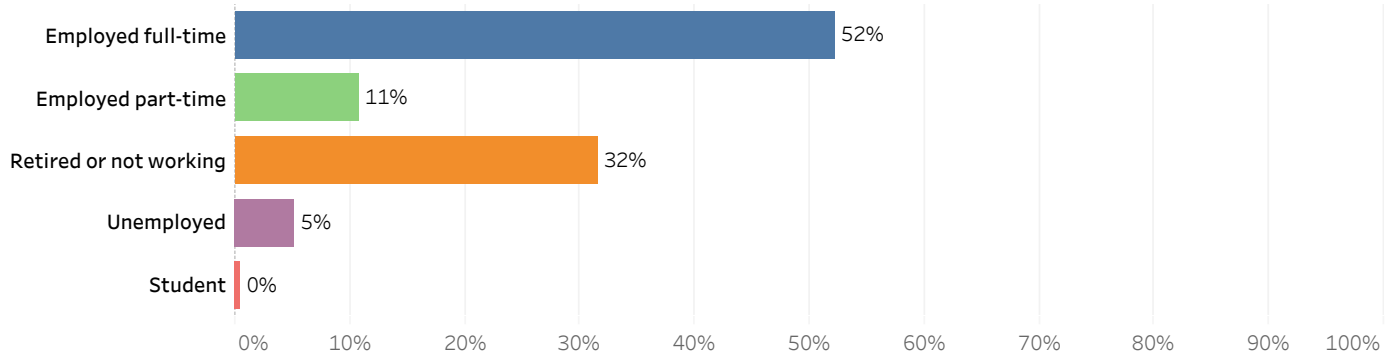

Most respondents (68%) have lived in Vermont for more than 20 years. Seventeen percent have lived in Vermont for 10 years or less and 15% have lived in Vermont for 11-20 years.

Figure 4: Years Lived in Vermont

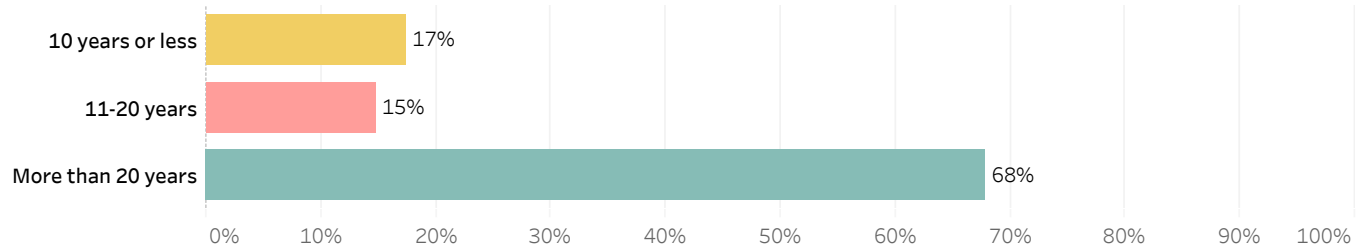

Four in ten (40%) Vermont residents describe the location of their residence as open country, but not a farm, 39% describe their home as located in a suburban setting, 18% describe it as in an urban setting, and 4% describe their home location as on a farm.

Figure 5: Which best describes the location of your residence?

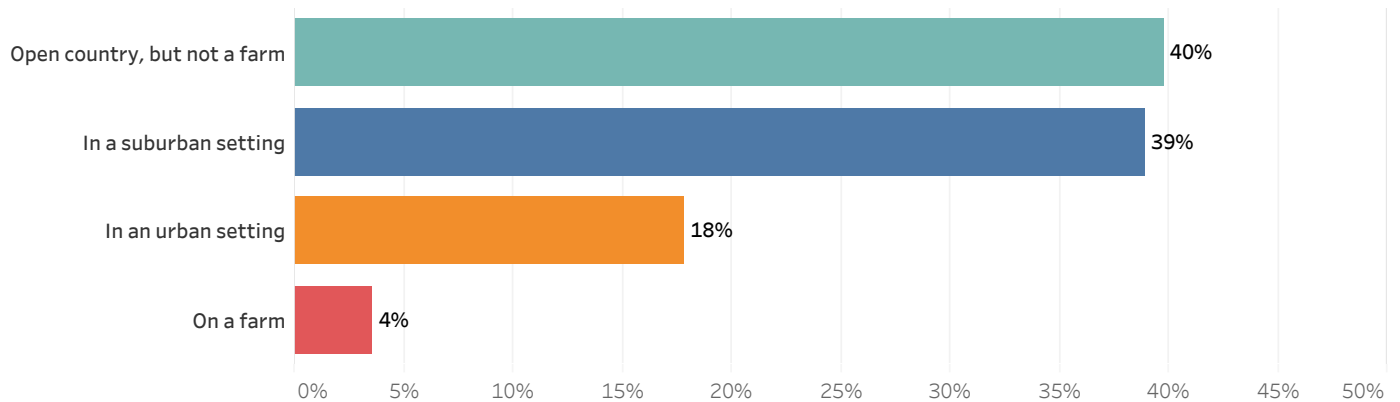

Seven in ten (70%) Vermont residents describe the housing unit they live in as a detached single-family home, 20% describe it as an apartment or duplex, 5% say they live in a townhouse or condominium, 2% live in a mobile home, and 3% live in another type of residence.

Figure 6: Which of the following comes closest to the kind of housing unit you now live in?

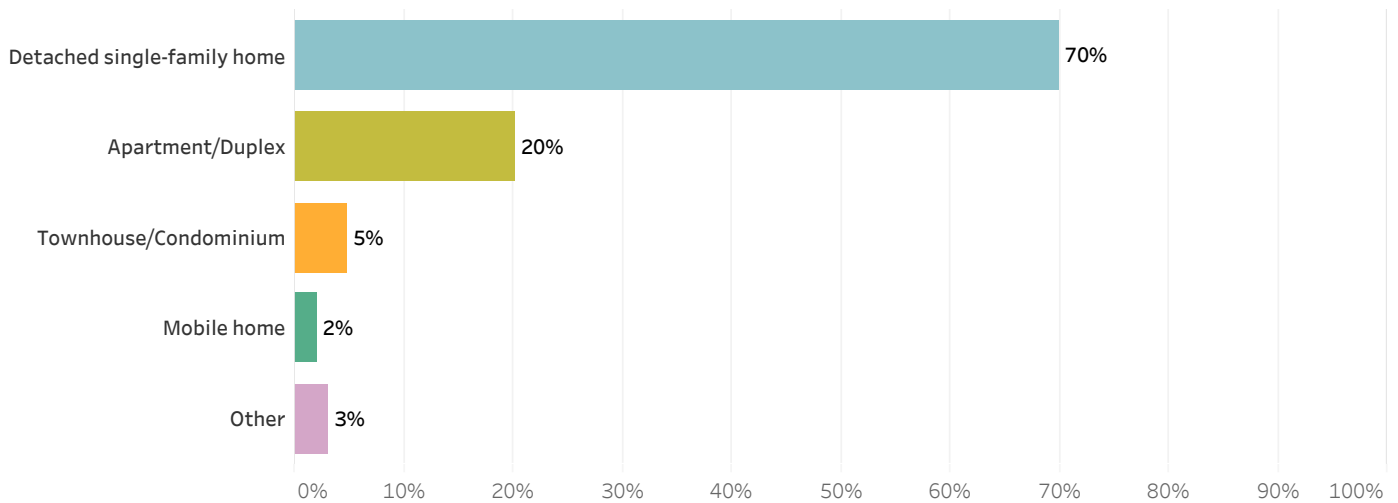

Eighty-three percent of Vermont residents say that they have a yard or outside space on which they can garden, while 17% do not.

Figure 7: Whether or not anyone in your household gardens, do you have a yard or outside space on which you can garden?

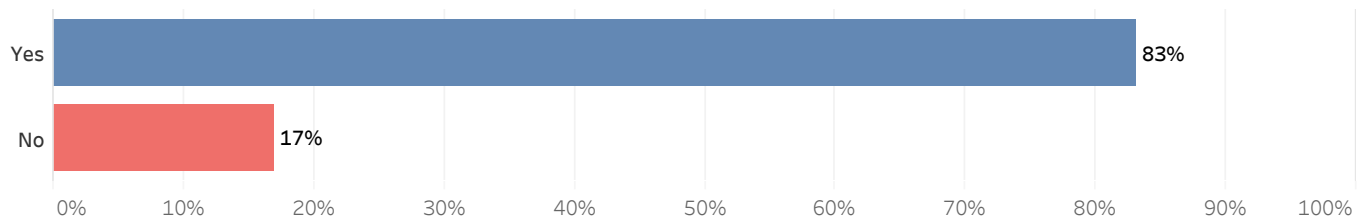

Vermont Universal Recycling Law

More than half of Vermonters (57%) say that they believe Vermont residents are very informed (8%) or informed (50%) about the Vermont Universal Recycling Law, which banned food scraps and other organic waste that decomposes from being disposed of in regular trash and landfills. Seventeen percent say they believe Vermonters are neither informed nor uninformed about this change, while a quarter (26%) say Vermonters are uninformed (21%) or very uninformed (5%) about this change.

Figure 8a: In 2020, the Vermont Universal Recycling Law (Act 148) banned food scraps and other organic waste that decomposes from being disposed of in regular trash and landfills. In your opinion, how informed or uninformed are Vermonters about this change?

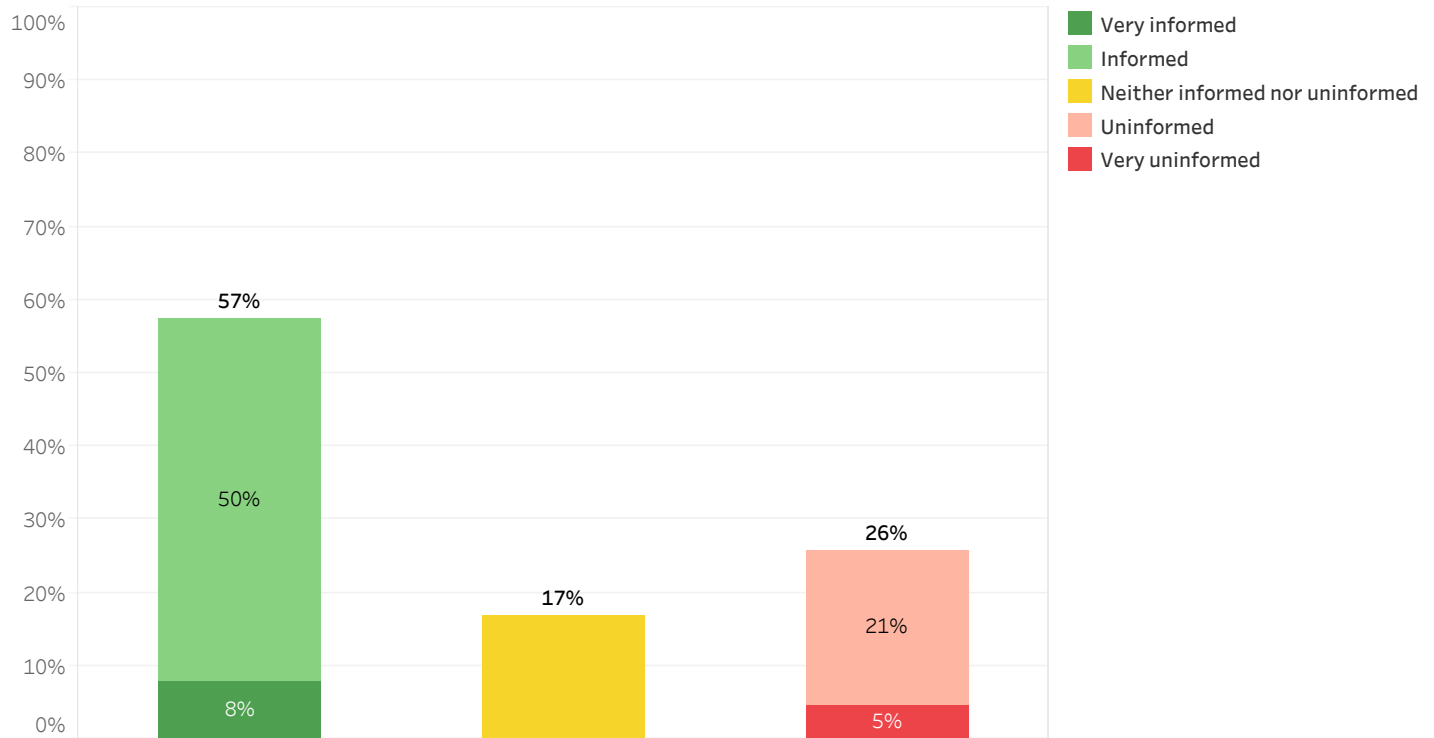

Younger respondents, those who live in an apartment or duplex, those with a lower household income, and those who rent their home are less likely than others to feel that Vermonters are very informed or informed about this change.

Figure 8b: Feel Vermonters are Very Informed or Informed About This Change - By Select Demographics

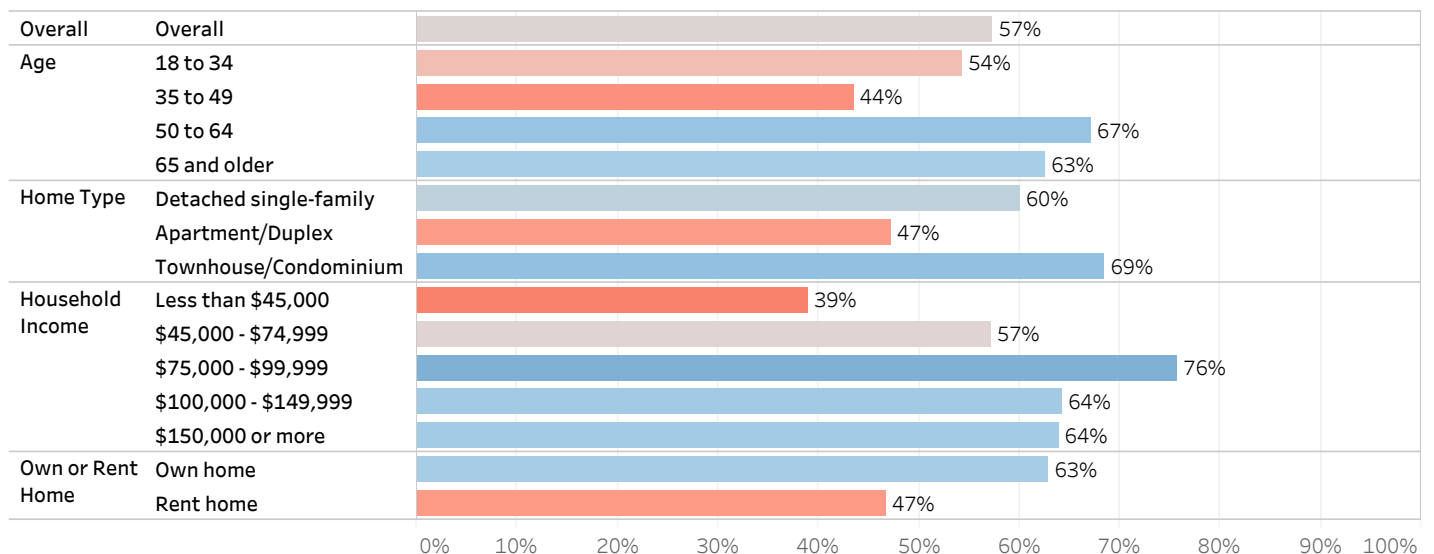

Statements About Composting

More than four-fifths of Vermont residents (82%) think it is very true (58%) or mostly true (24%) that composting food scraps is good for the environment, more than two-thirds think it is very true or mostly true that Vermonters should compost food scraps (69%), and just over half think it is very true or mostly true that composting food scraps is easy (54%).

When it comes to negative statements surrounding composting, more than half of Vermonters (57%) think it is very true (31%) or mostly true (26%) that compost piles and bins attract pests like insects and vermin, 43% think it is very true or mostly true that composting food scraps smell bad, and less than one-third think it is very true or mostly true that they don't have the space to compost food scraps (28%), composting food scraps is not worth the effort (23%), and that composting food scraps is too much work (22%).

Figure 9a: Whether or not you currently compost food scraps, we'd like to know how true each statement below is for you

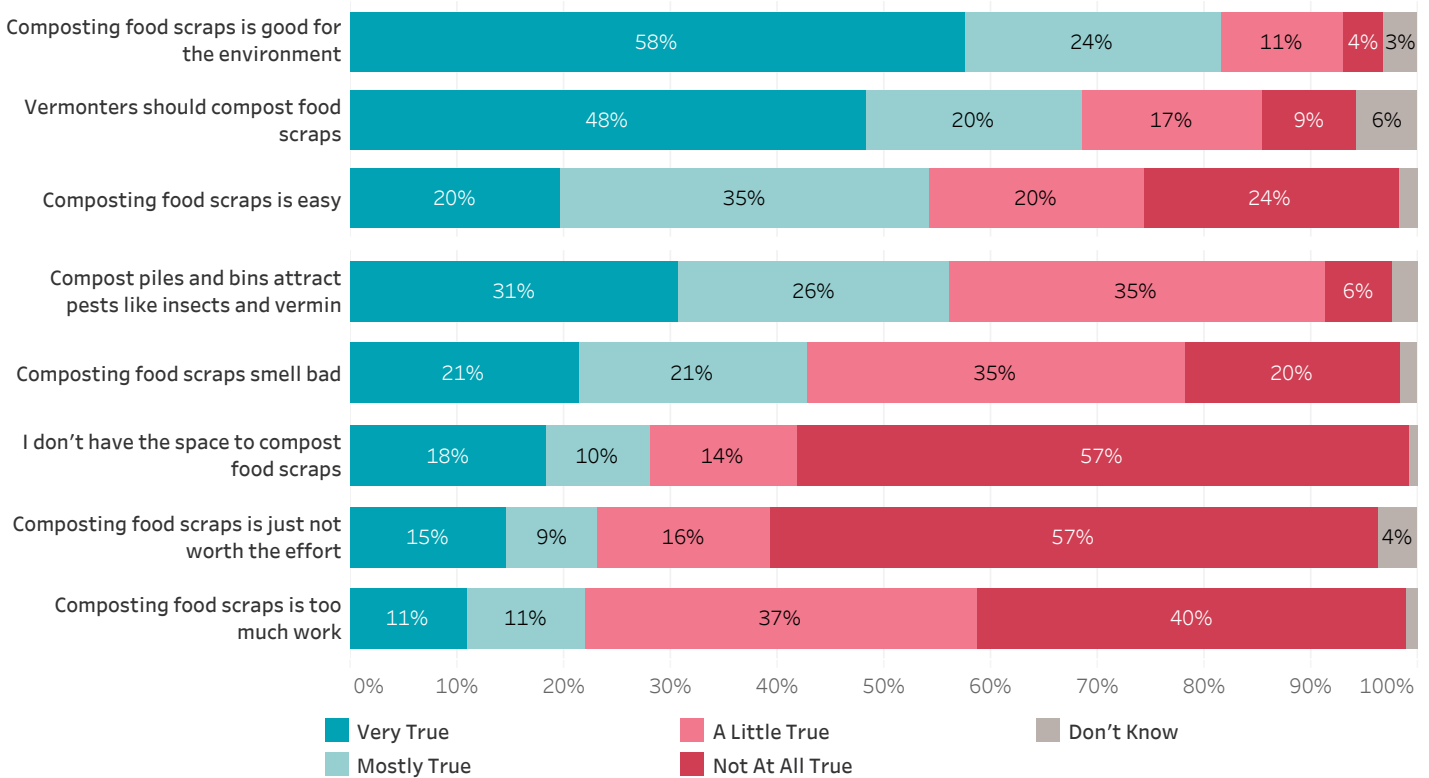

Women, those with higher levels of education, those who have lived in the state for 10 years or less, and those who live in the Northern Vermont are more likely than others to say the statement that composting good scraps is good for the environment is very or mostly true.

Figure 9b: Feel following statements are very true or mostly true - by Select Demographics

Composting food scraps is good for the environment

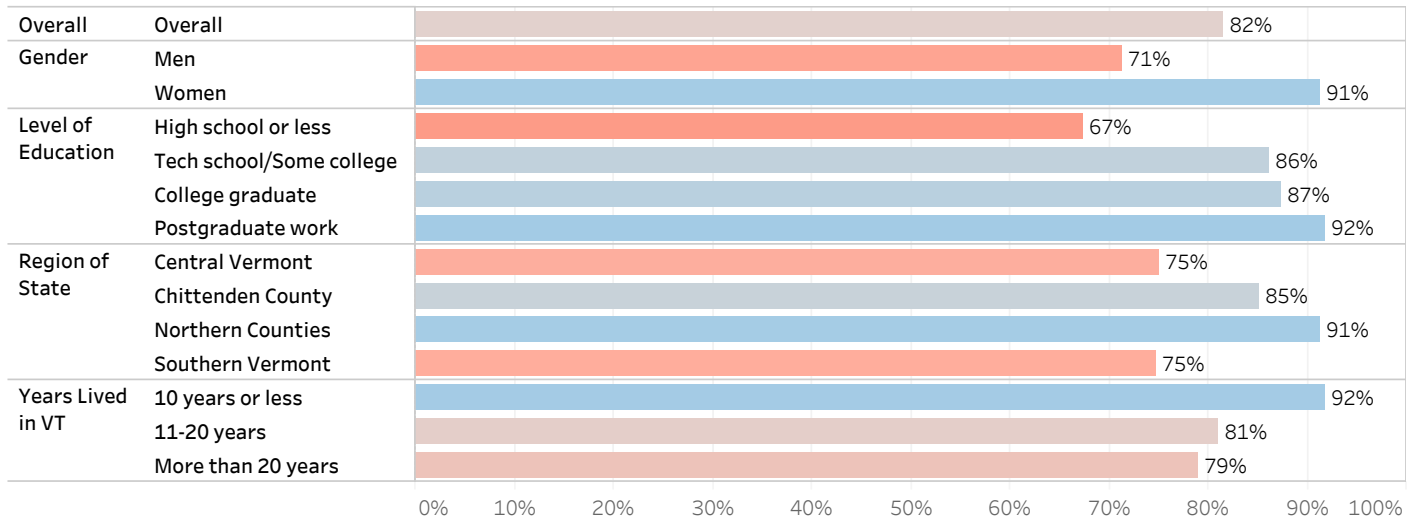

Women, respondents with higher levels of education, those who have lived in the state for 10 years or less, those who live in the Chittenden County, and those with a household income between \$75,000 and \$149,999 are more likely than others to say the statement that Vermont should compost food scraps is very or mostly true.

Figure 9c: Feel following statements are very true or mostly true - by Select Demographics

Vermonters should compost food scraps

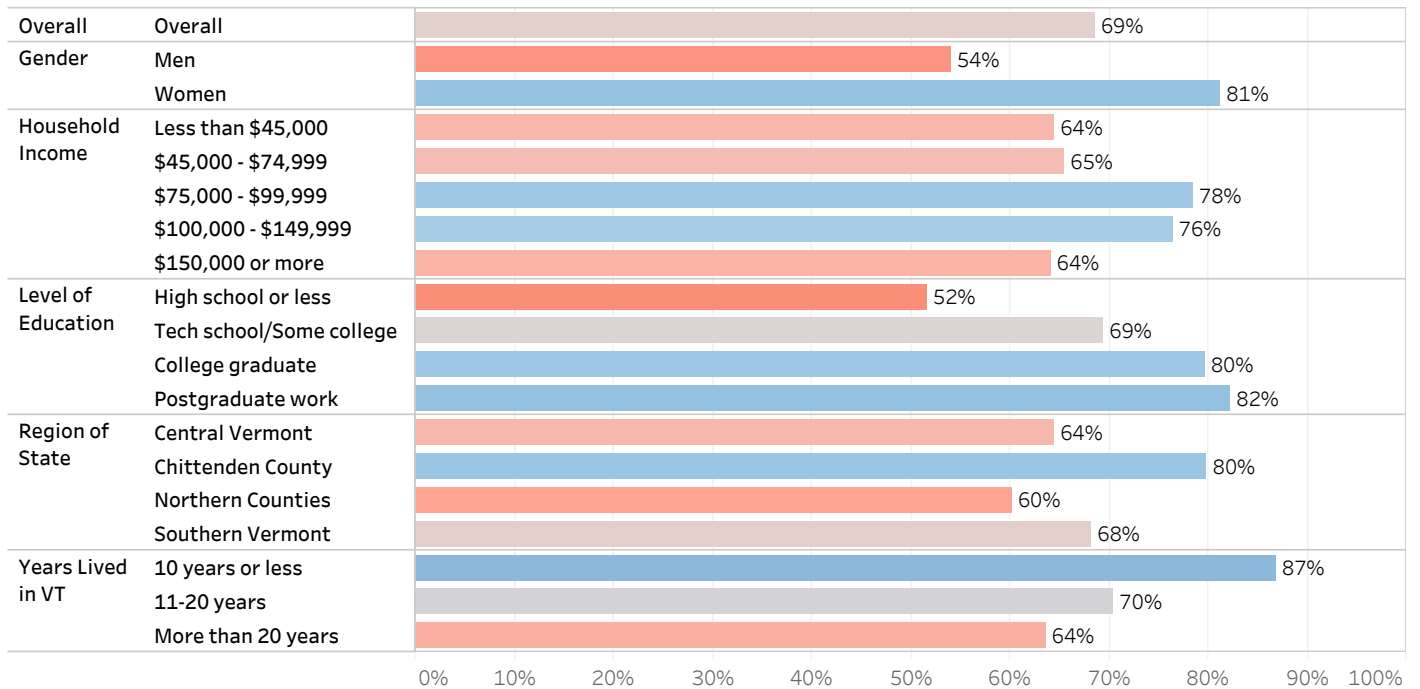

Respondents with no children in their household, those who live in an urban setting, those with a household income between \$45,000 and \$99,999, and those who live in Chittenden County or Southern Vermont are more likely than others to say the statement that composting food scraps is easy is very or mostly true.

Figure 9d: Feel following statements are very true or mostly true - by Select Demographics

Composting food scraps is easy

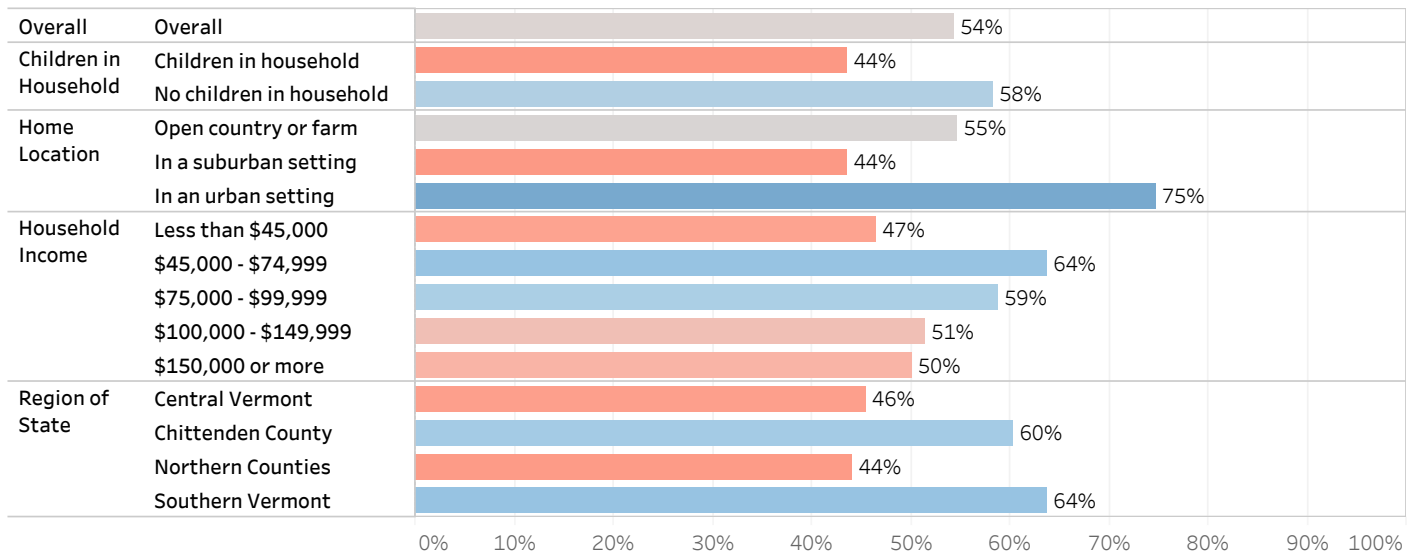

Respondents between the ages of 35 and 49, men, those living in a rural or suburban setting, those with lower levels of education, and those who have lived in Vermont for a longer period of time are more likely than others to say the statement that compost piles and bins attract pests like insects and vermin is very or mostly true.

Figure 9e: Feel following statements are very true or mostly true - by Select Demographics

Compost piles and bins attract pests like insects and vermin

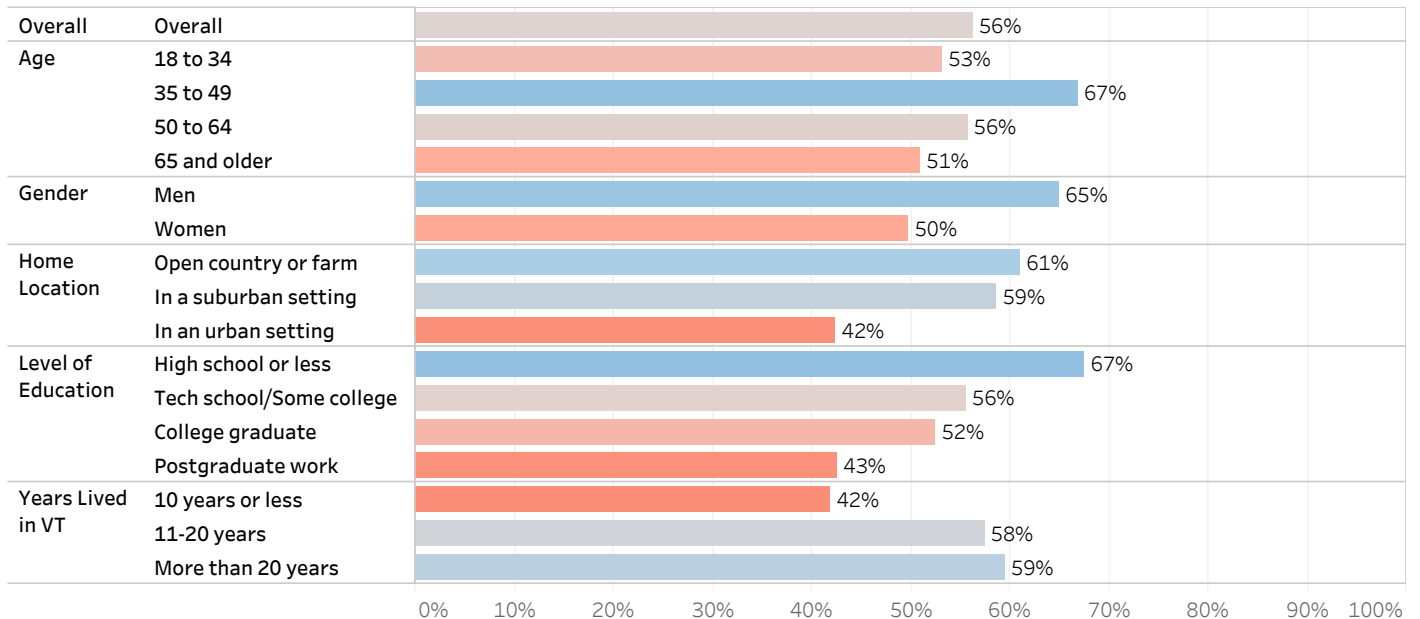

Younger respondents, those who live in an apartment or duplex, those with lower levels of household income, those with lower levels of education, those who rent their home, and those who have lived in Vermont for a longer period of time are more likely than others to say the statement that composting food scraps smell bad is very or mostly true.

Figure 9f: Feel following statements are very true or mostly true - by Select Demographics

Composting food scraps smell bad

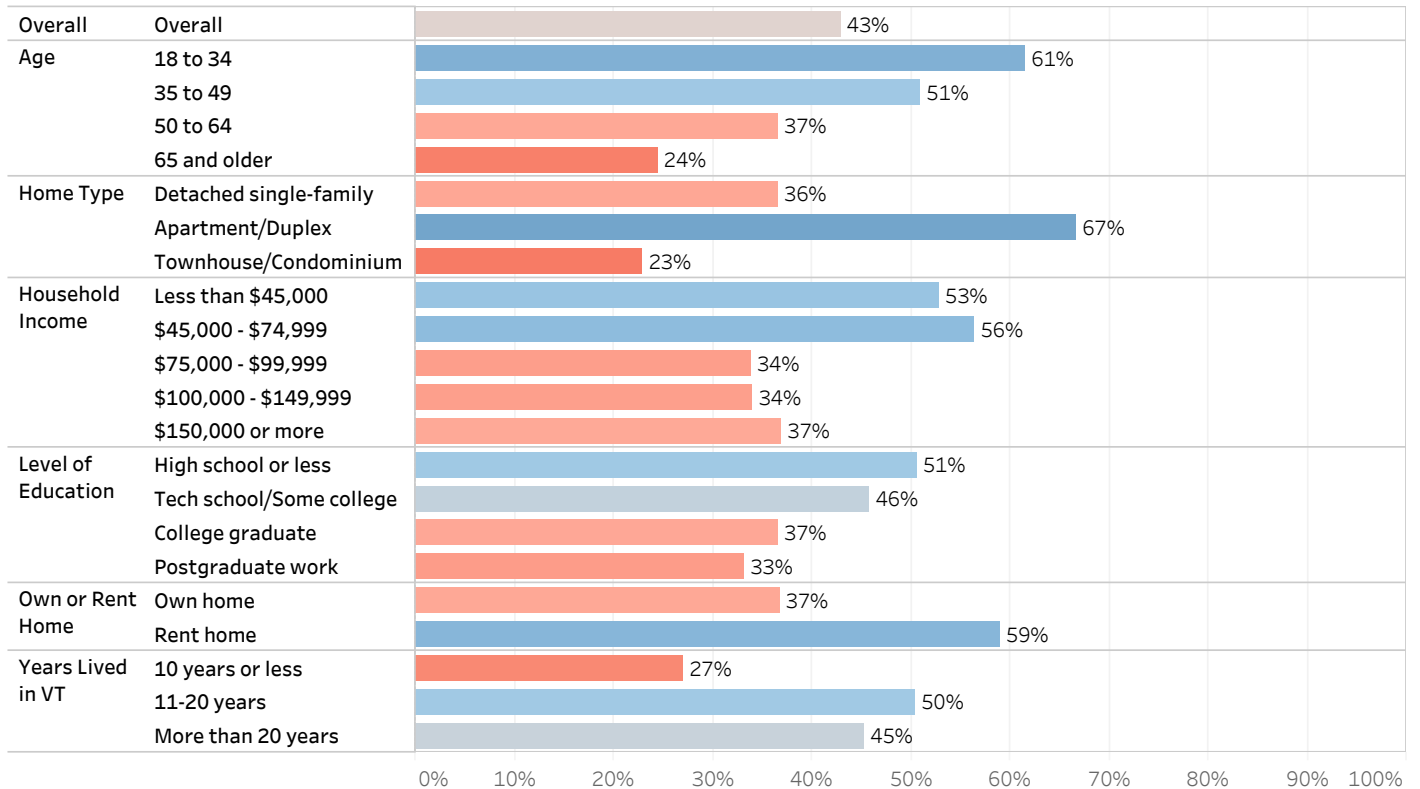

Younger respondents, those who live in a suburban or urban setting, those who live in an apartment or duplex, those with lower levels of household income, and those who rent their home are more likely than others to say the statement that they don't have the space to compost food scraps is very or mostly true.

Figure 9g: Feel following statements are very true or mostly true - by Select Demographics

I don't have the space to compost food scraps

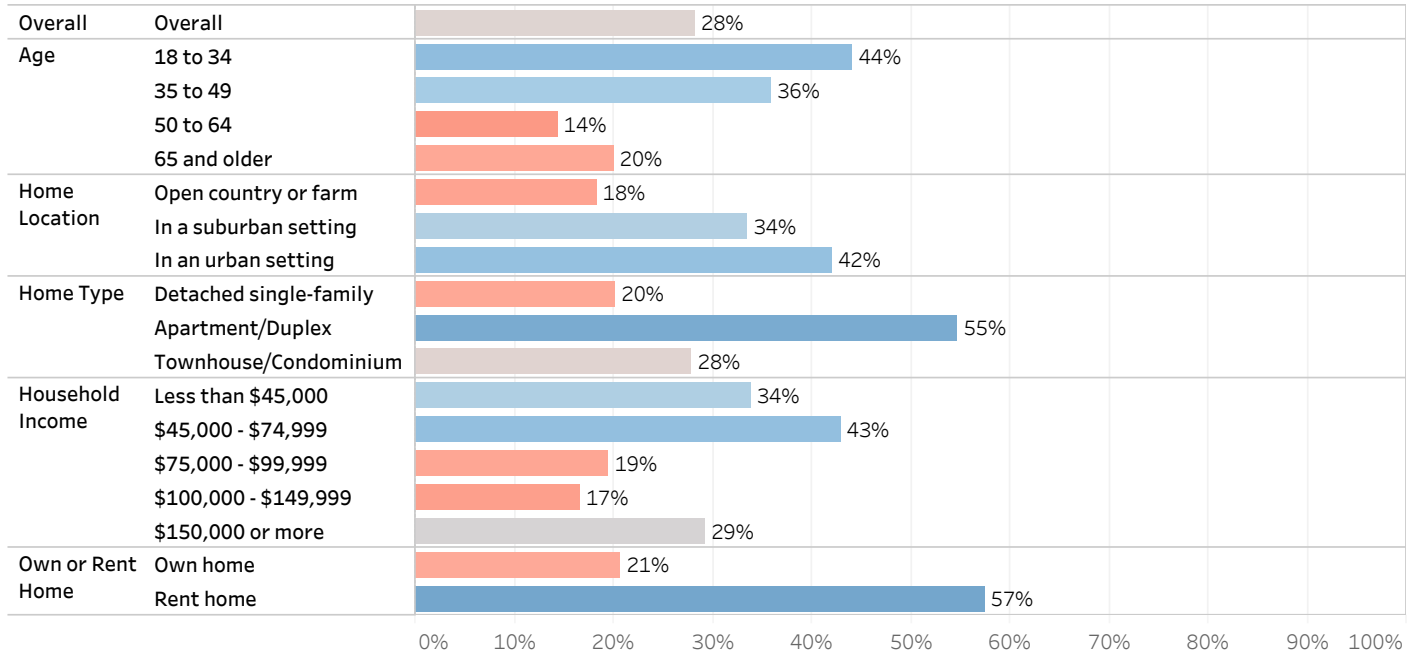

Men, those who live in an apartment or duplex, those with lower levels of household income, those with lower levels of education, those who rent their home, those who live in the Northern Counties and Central Vermont, and those who have lived in Vermont for more than 20 years are more likely than others to say the statement that composting food scraps is just not worth the effort is very or mostly true.

Figure 9h: Feel following statements are very true or mostly true - by Select Demographics

Composting food scraps is just not worth the effort

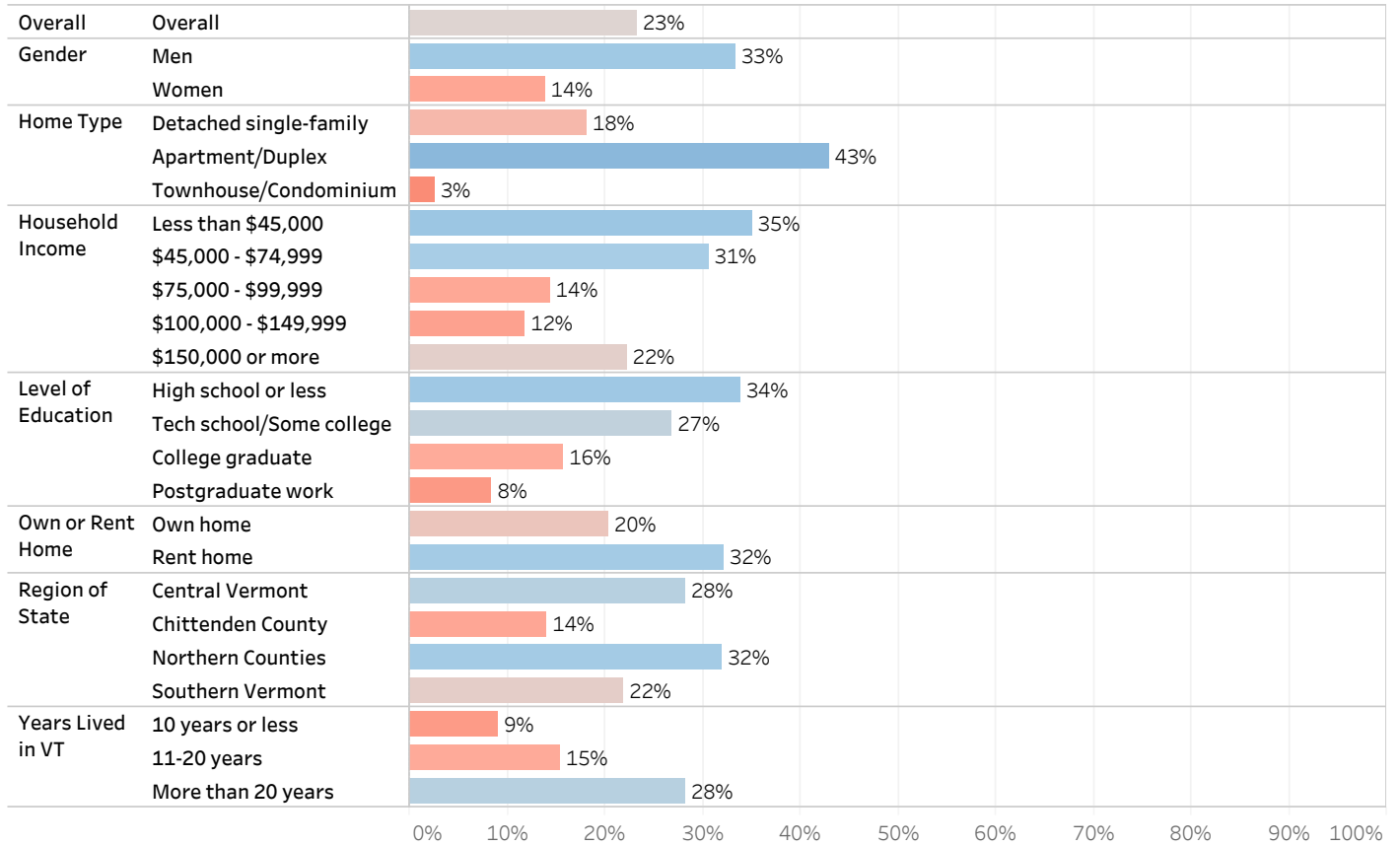

Men, those who live in an apartment or duplex, those with lower levels of household income, those with lower levels of education, those who live in Central Vermont, and those who have lived in Vermont for a longer amount of time are more likely than others to say the statement that composting food scraps is too much work is very or mostly true.

Figure 9i: Feel following statements are very true or mostly true - by Select Demographics

Composting food scraps is too much work

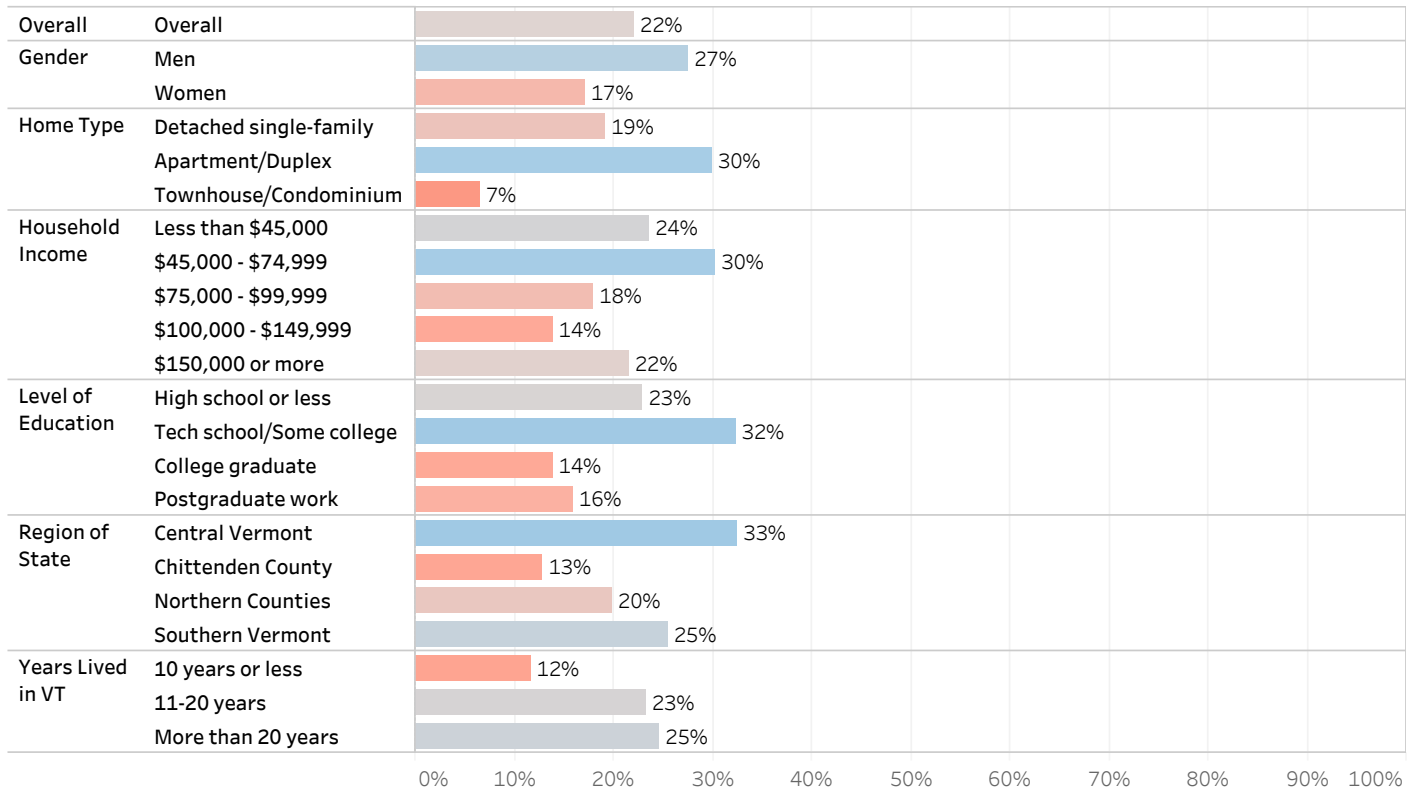

Composting Behavior

When asked what they do with food waste, 43% of Vermonters say that they set food waste aside for composting in their backyard or their own compost pile while 36% say that they put it in with the regular trash. Fewer Vermonters say that they set aside the food waste and the compost is dropped off at a transfer station or collection site (13%), put it down the garbage disposal or sink (12%), set it aside for composting being picked up by a waste hauler (12%), feed it to farm animals or livestock (12%), or feed it to pets (9%). Thirteen percent say that they do something else, while 1% don't know.

Overall, 21% say that they exclusively put their food scraps in the regular trash or down the garbage disposal or sink and do not compost or feed food scraps to animals at all.

Figure 10a: What does your household do with food waste that comes from eating or preparing food including any scraps, inedible parts, and spoiled or rotten foods? (Select all that apply)

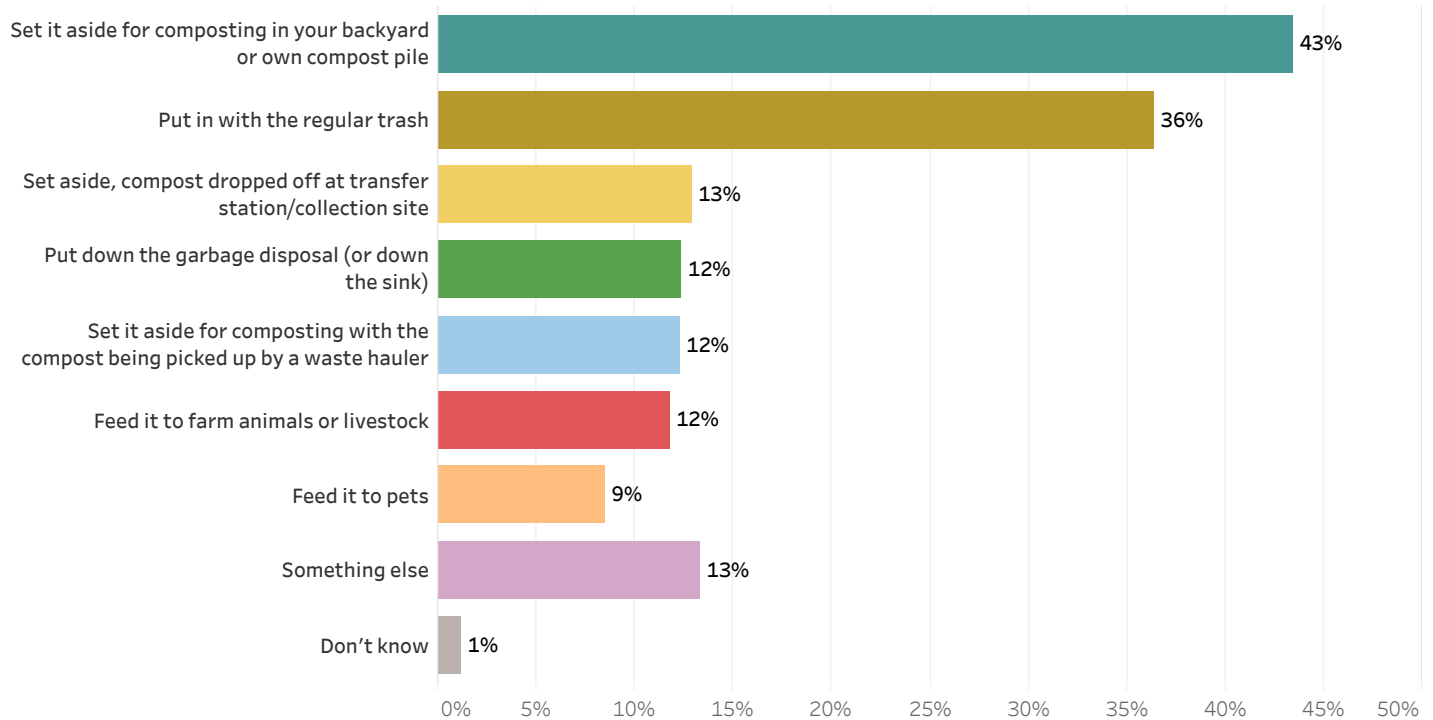

Figure 10b: What does your household do with food waste that comes from eating or preparing food including any scraps, inedible parts, and spoiled or rotten foods? (Select all that apply) - Other - Selected Quotations

"Allow wild animals to eat"

"Flush in the toilet"

"I have a mini composter (Lomi) in the kitchen."

"Put it in a bin in the freezer"

"Varies by type of food & season"

Respondents in Central and Southern Vermont are more likely than others to set aside food waste for composting in their backyard or own compost pile. Respondents in Chittenden County are more likely than others to set aside food waste for composting, with the compost being picked up by a waste hauler or dropping the compost off at a transfer station/collection site. Respondents in the Northern Counties are more likely than others to put food waste down the garbage disposal or feed it to pets, and respondents in the Northern Counties and Southern Vermont are more likely than others to feed it to farm animals or livestock.

Figure 10c: What does household do with food waste - by Region

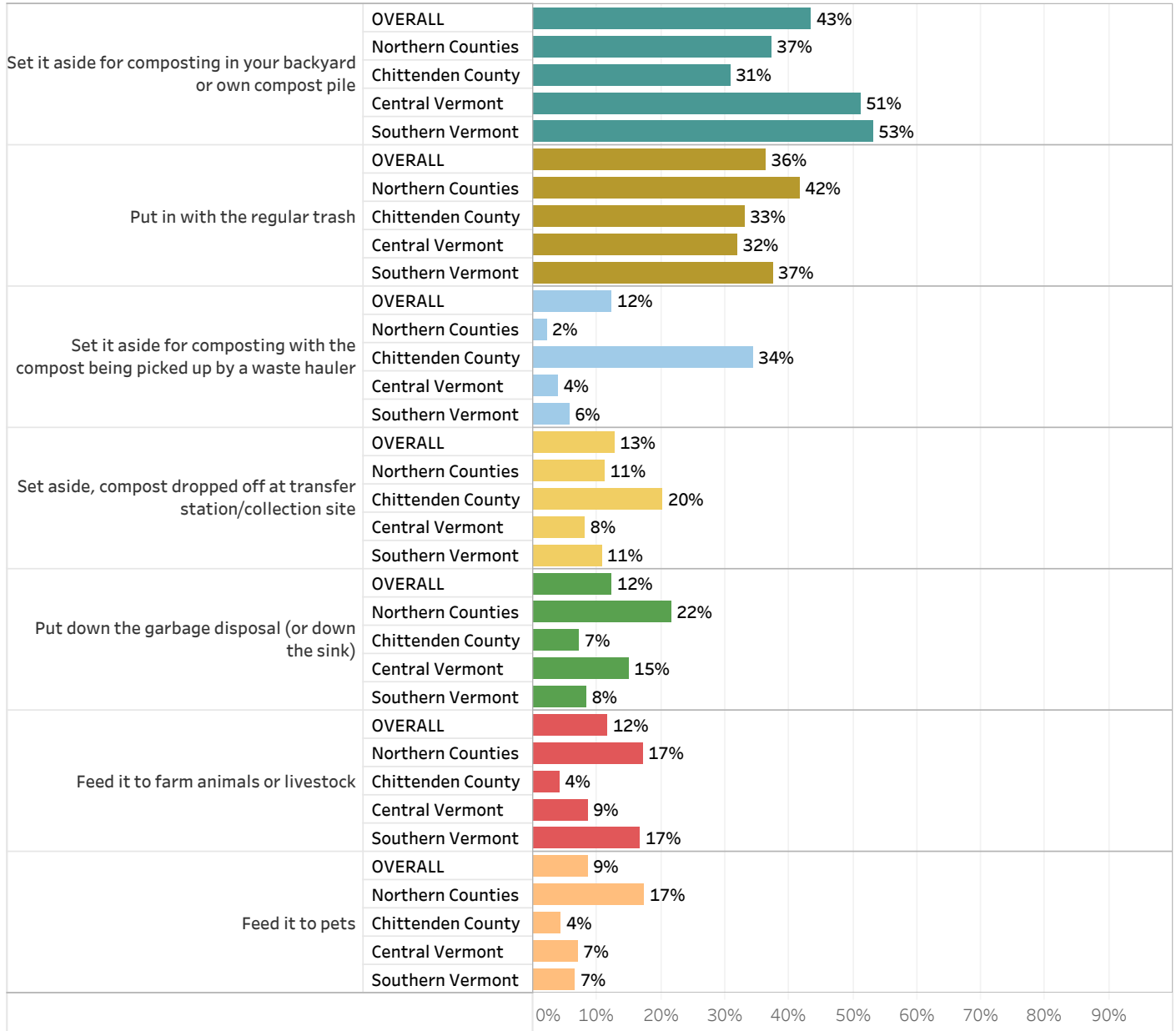

Younger respondents are more likely than others to say they put household food waste in with the regular trash. Older respondents are more likely than others to say they set aside food waste for composting in their backyard or their own compost pile.

Figure 10d: What does household do with food waste - by Age

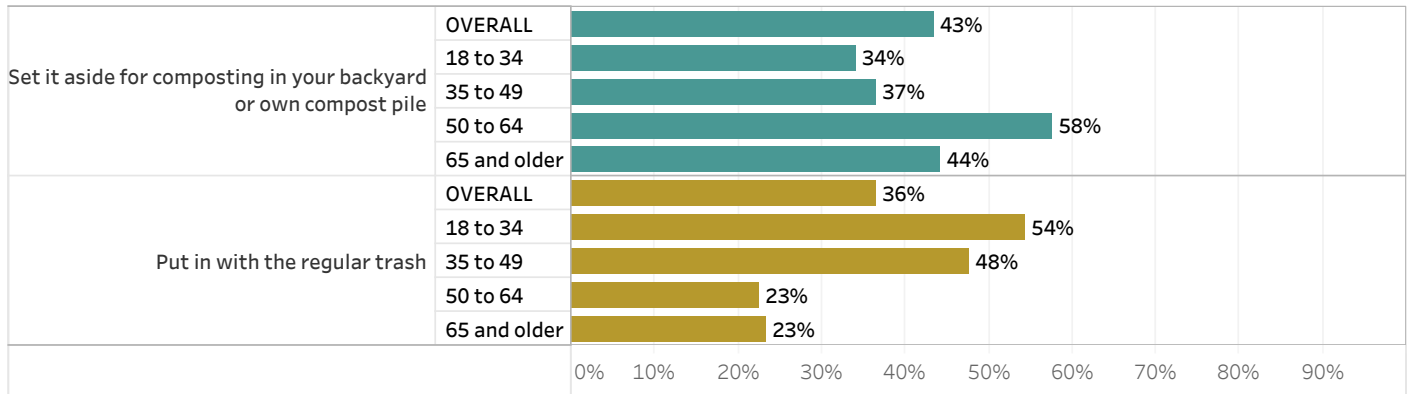

Respondents who own their home are more likely than others to set food waste aside for composting in their backyard or own compost pile. Respondents who rent their home are more likely than others to put food waste in with the regular trash or set it aside for composting with the compost being picked up by a waste hauler.

Figure 10e: What does household do with food waste - by Home Ownership Status

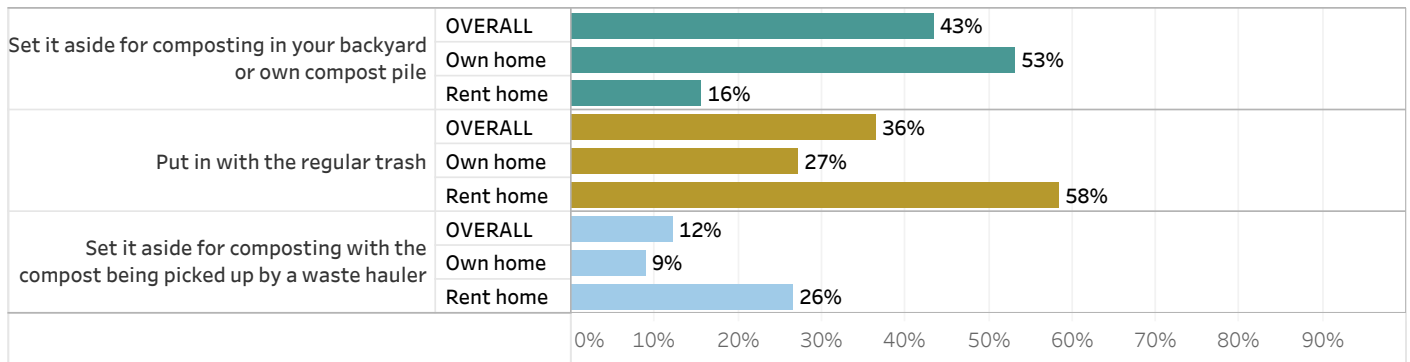

Women are more likely than others to say they set food waste aside for composting in their backyard or own compost pile, or for being picked up by a waste hauler.

Figure 10f: What does household do with food waste - by Gender

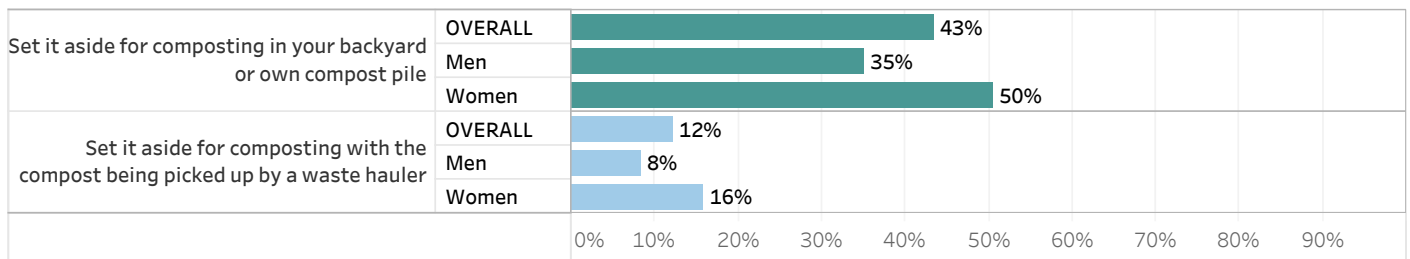

Respondents who live in open country or on a farm are more likely than others to say they set aside food waste for composting in their backyard or their own compost pile. Respondents who live in a suburban or urban setting are more likely than others to set aside food waste for composting to be picked up by a waste hauler or to be dropped off at a collection site. Respondents who live in a suburban setting are more likely than others to say they put food waste down the garbage disposal.

Figure 10g: What does household do with food waste - by Home Location

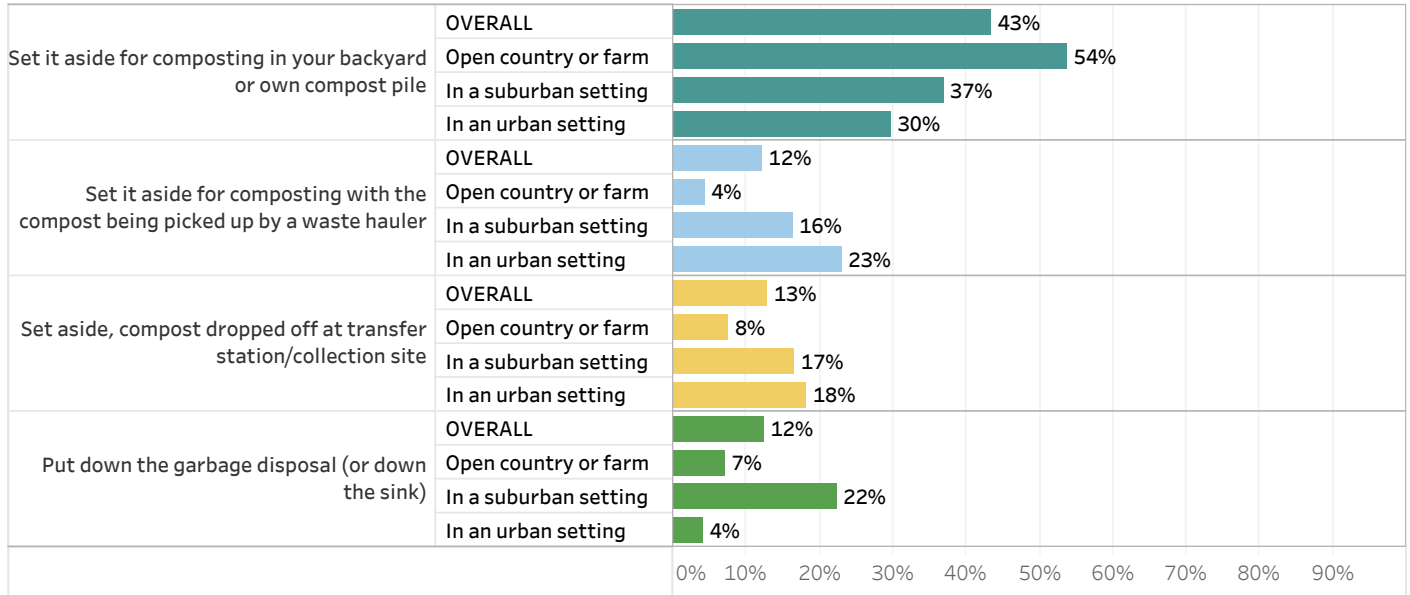

Respondents who live in a detached single-family house are more likely than others to set aside food waste for composting in their backyard or own compost pile. Respondents who live in an apartment or duplex are more likely than others to put food waste in with the regular trash. Respondents who live in a townhouse or condominium are more likely than others to set food waste aside for composting with the compost being picked up by a waste hauler.

Figure 10h: What does household do with food waste - by Home Type

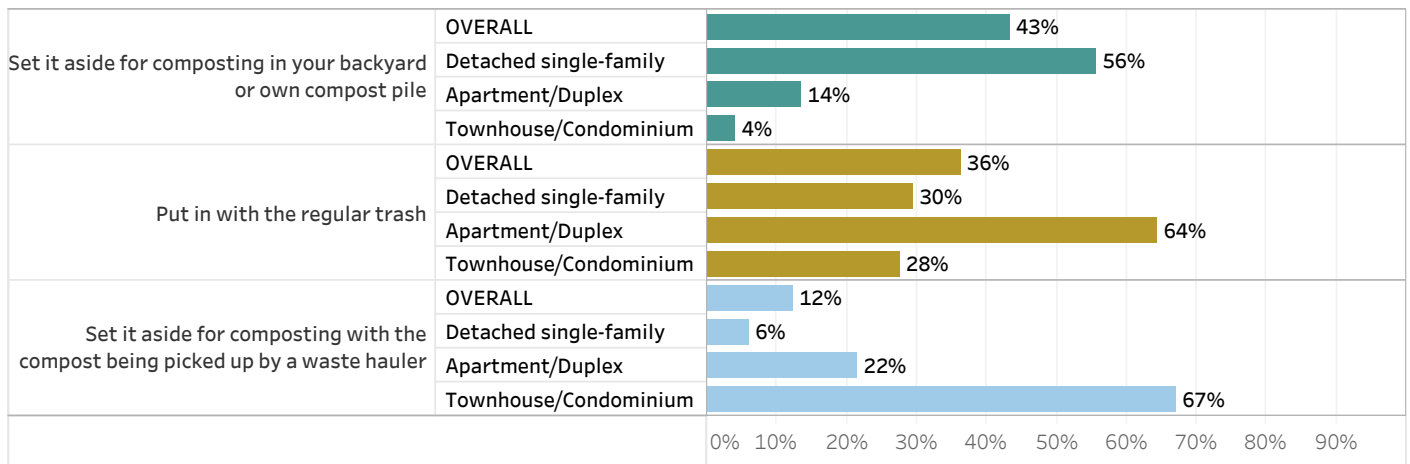

Respondents with higher household incomes are more likely than others to set food waste aside for composting in their backyard or their own compost pile. Respondents with lower household incomes are more likely than others to put food waste in with the regular trash or down the garbage disposal.

Figure 10i: What does household do with food waste - Selected Methods - by Household Income

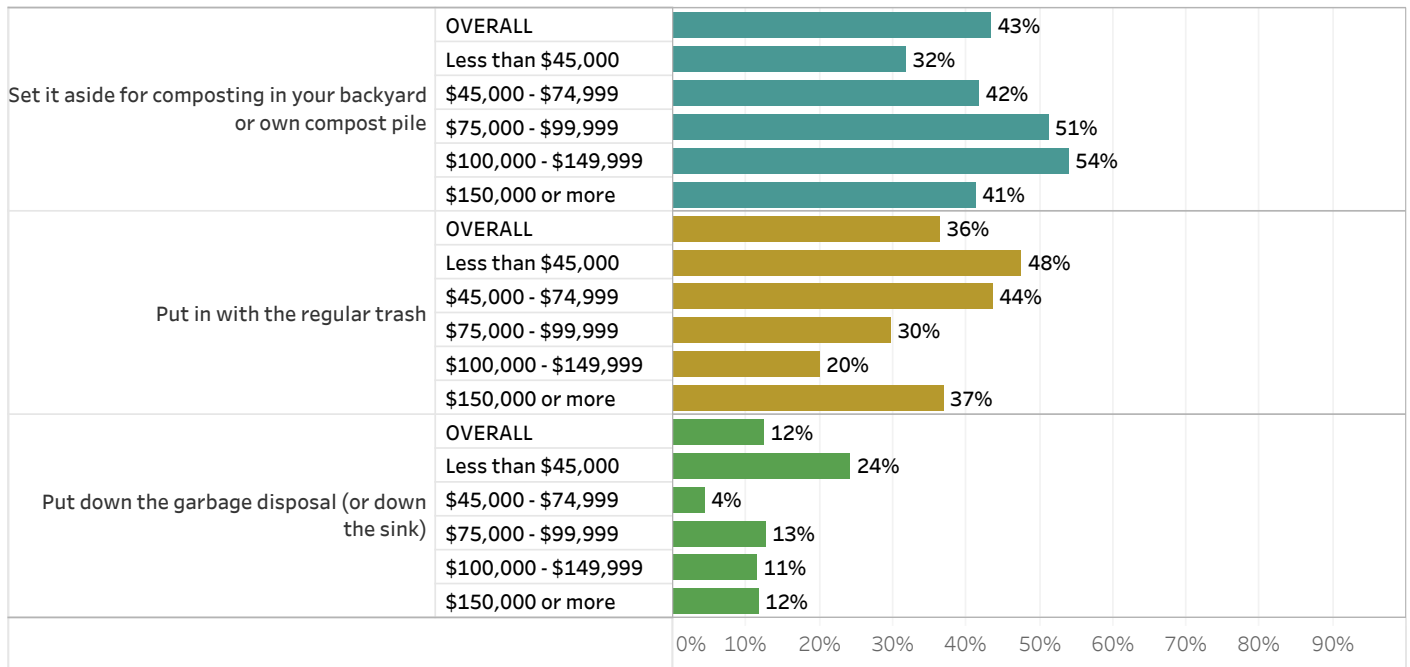

Respondents with higher levels of education are more likely than others to say they set food waste aside for composting in their backyard or own compost pile, or that they set aside food waste to be dropped off at a transfer station or collection site.

Figure 10j: What does household do with food waste - Selected Methods - by Level of Education

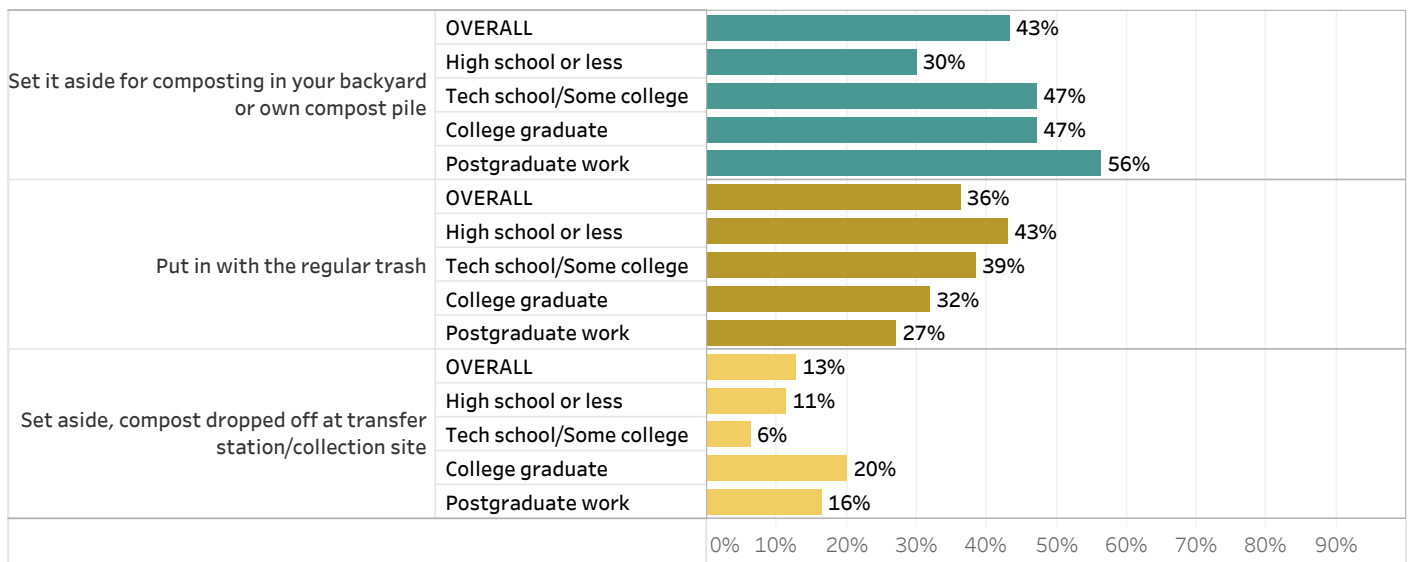

Among those who say their household composts food waste or feeds it to animals (N=714), 19% say that the size of the container their household uses to set aside items for composting or animal feed is about the size of a large 5 gallon bucket, 18% say it is about the size of a 2 gallon bucket, 39% say it is about the size of a gallon of milk, 8% say it is about the size of a half-gallon of milk, 9% say it is about the size of a quart of milk, and 6% say it is another size.

Figure 11a: Which best describes the size of the container your household uses to set aside items for composting or animal feed?

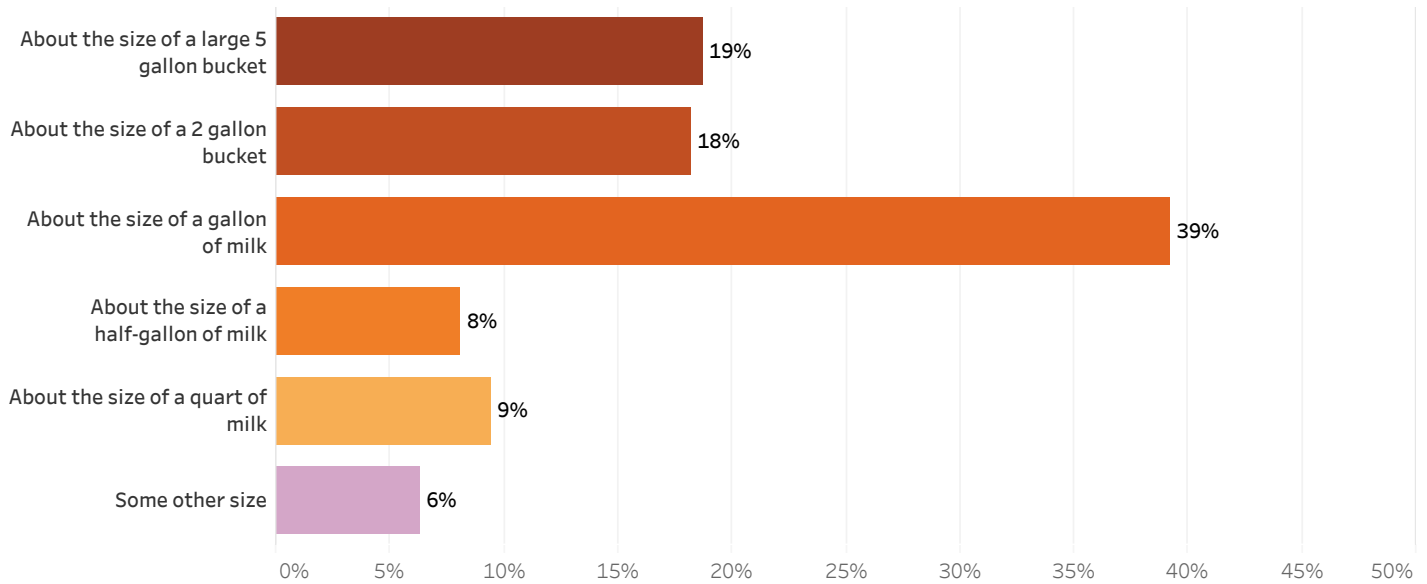

Respondents who live in an urban setting, those who live in an apartment or duplex, those with lower levels of education, those who rent their home, those who live in Chittenden County, and those who have lived in Vermont for a longer amount of time are more likely than others to have a container for composting or animal feed that is 2 gallons or more.

Figure 11b: Size of container household uses to set aside items for composting or animal feed - by Select Demographics
2 Gallons or more

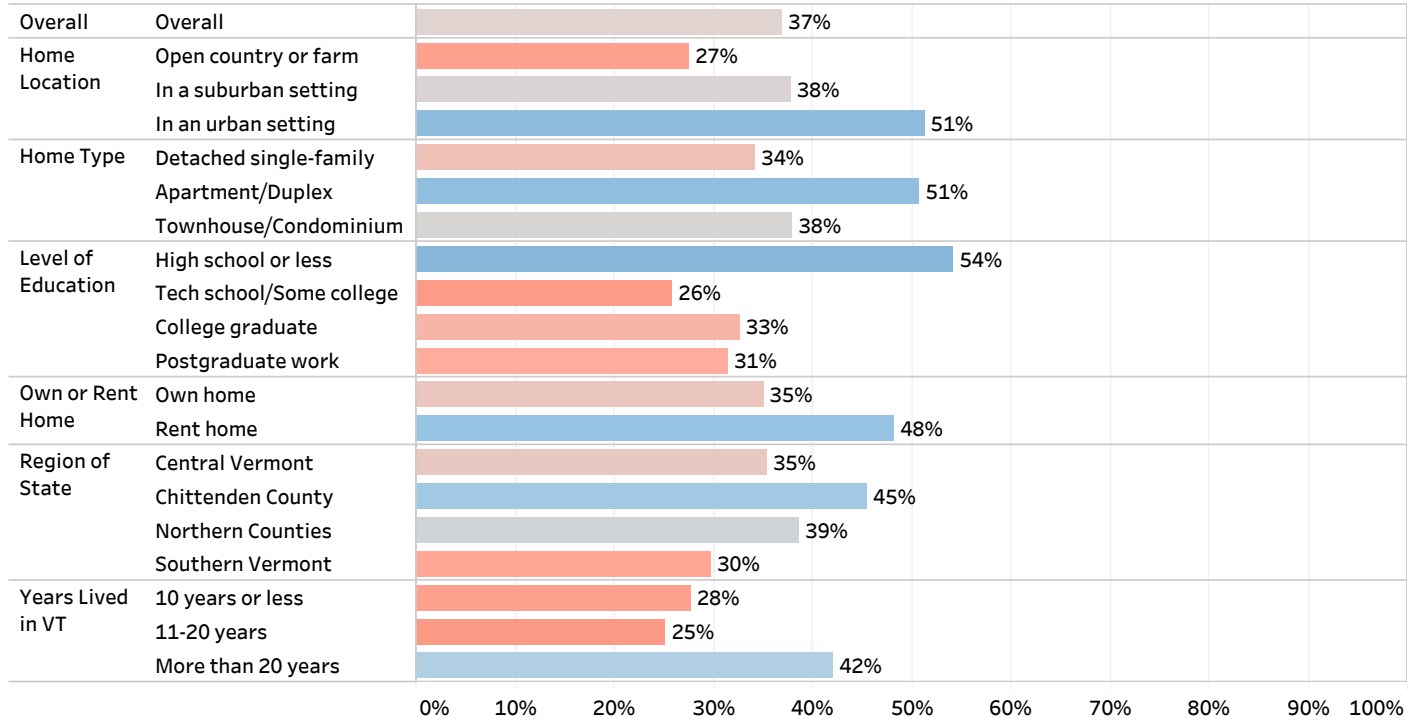

Among those who say their household composts food waste or feeds it to animals, 1% say that last week their household emptied the container they use for composting or animal feed more than once a day, 12% emptied it daily, 1% emptied it six times a week, 4% emptied it five times a week, and 5% emptied it four times a week. A larger proportion emptied their container three times a week (16%), twice a week (21%), or once per week (23%), while 8% emptied their container for composting or animal feed less than once a week and 9% did not set aside items for composting or animal feed.

Among those with a container about the size of a 5 gallon bucket, a majority (59%) empty the container once per week or less often, while among those with the smallest containers, four in ten (40%) say they empty their containers daily.

Figure 12a: Thinking about last week, about how often did your household empty the container used to set items aside for composting or animal feed?

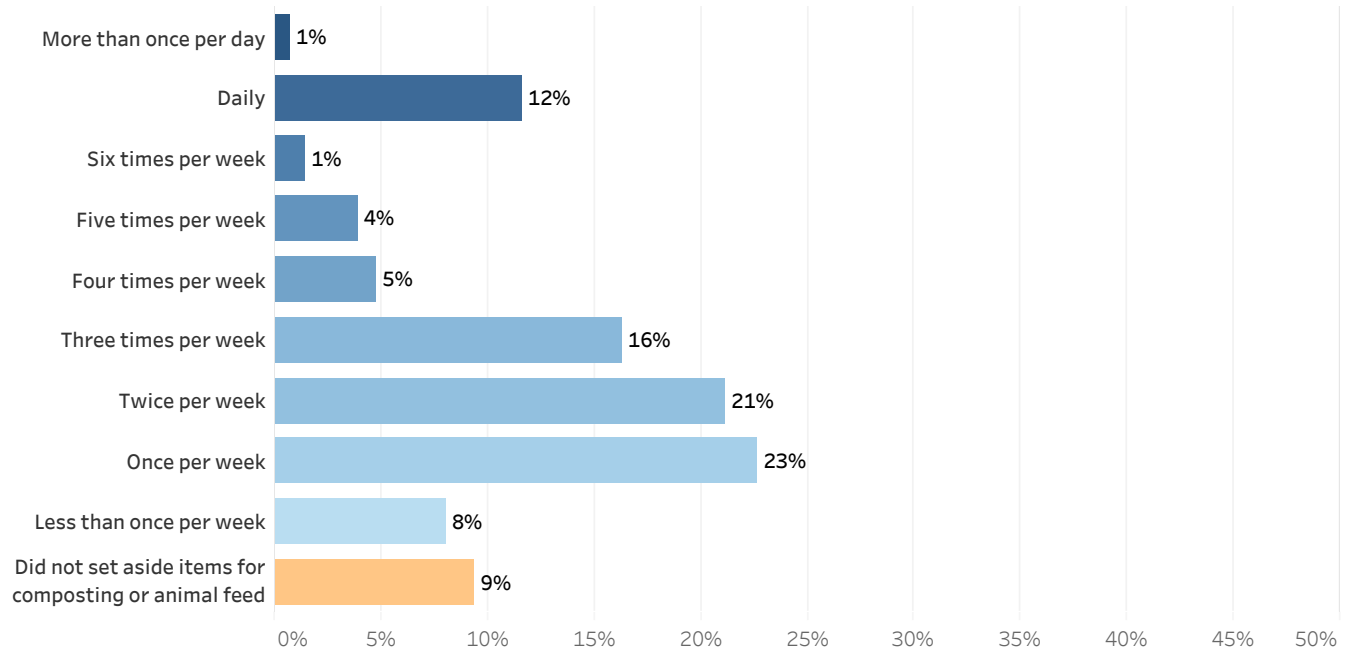

Older respondents, those who live in a detached single-family home, those with lower levels of household income, those who own their home, and those who live in Central Vermont are more likely than others to say their household empties their container three times per week or more.

Figure 12b: How often did household empty container last week - by Select Demographics

Three times per week or more

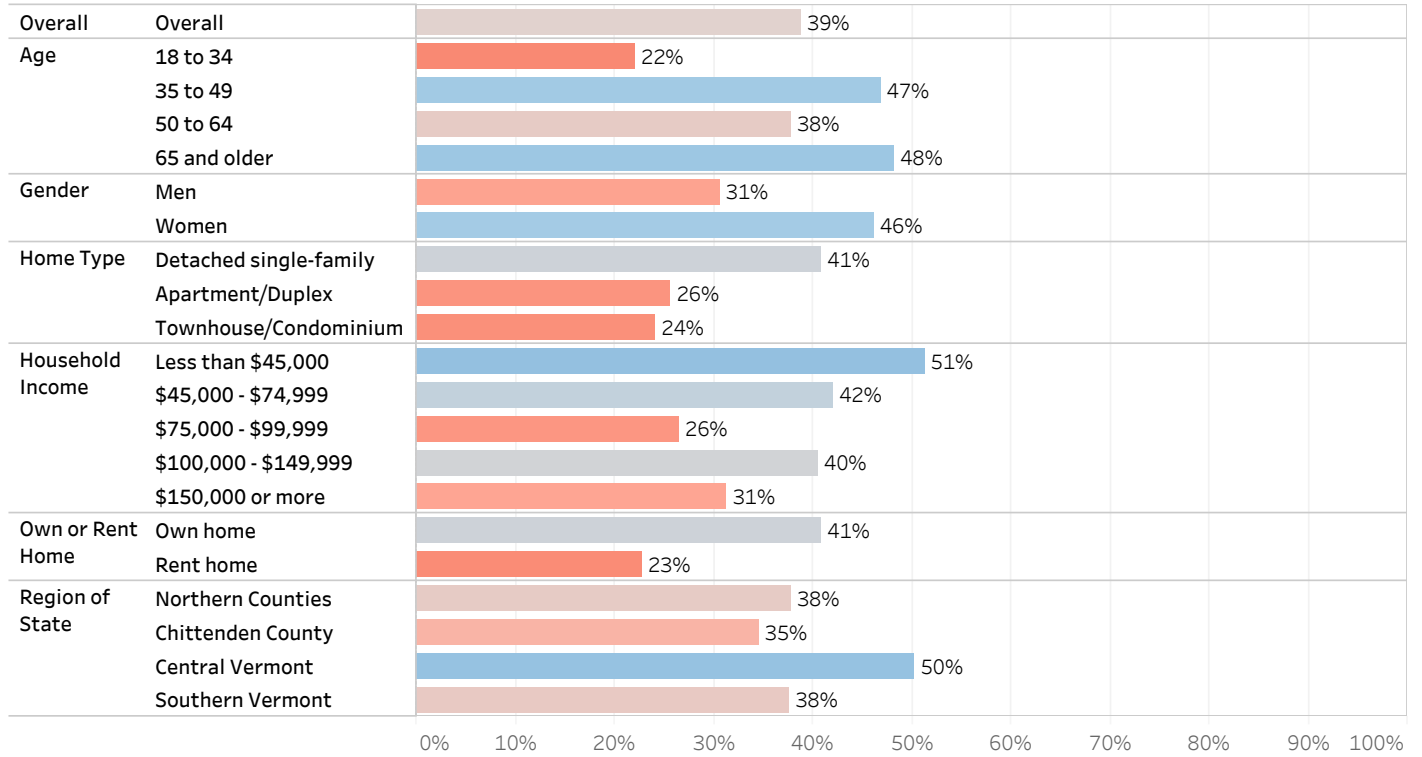

More than half (55%) say that last week, when their household emptied their container used for composting or animal feed, the container on average was completely or almost full. Just over a quarter (28%) say that on average their container was about three-quarters full, 15% say it was on average about half full, and only 2% say it was on average about a quarter full or less.

Figure 13a: On average, how full was the container when it was emptied?

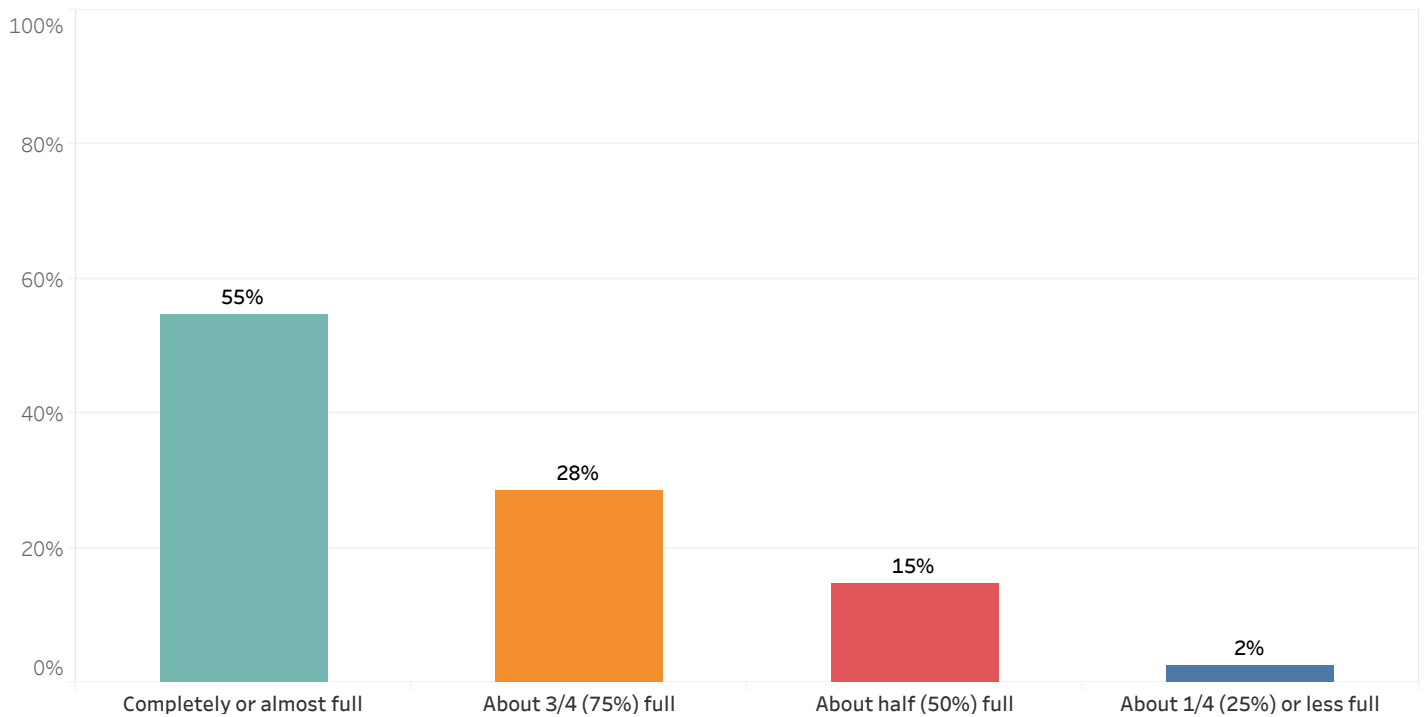

Women, those who live in a detached single-family home, and those with higher levels of household income and education are more likely than others to say they container was completely or almost full when it was emptied.

Figure 13b: How full was container when emptied - by Select Demographics

Completely or almost full

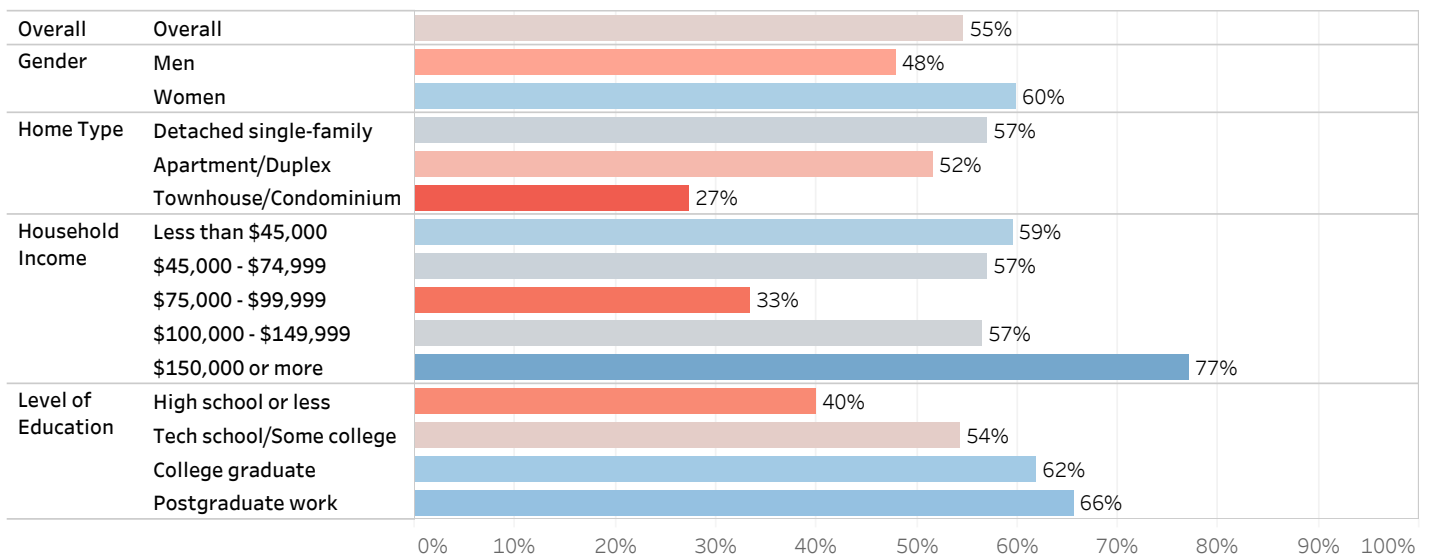

Estimates for Statewide Composting

To estimate how much of our food scraps are being composted or fed to animals, livestock, or pets, we first estimated the amount of scraps put aside for composting in those homes that compost. This estimate comes from the following three questions:

1. Q4: Which best describes the size of the container your household uses to set aside items for composting or animal feed?
2. Q5: Thinking about last week, about how often did your household empty the container used to set items aside for composting or animal feed?
3. Q6: On average, how full was the container when it was emptied?

Based on these questions, we used the following simple equation:

$$\text{Compost per week} = [\text{container size in gallons (Q4)} * \text{number of times container is emptied (Q5)} * \text{average capacity filled when emptied (Q6)}]$$

For households that compost, we estimate an average of 3.35 gallons is set aside for composting or feeding to animals. Because the composting material is not packed down, we are estimating that one gallon is equal to about 5 pounds; consequently, households that engage in composting put aside an average of 16.75 pounds per week. Averaging this out across all households – those that compost as well as those that do not—we estimate composting material at 13.23 pounds per household per week, or 688 pounds per household per year.

If we employ additional information from Q7, we can estimate that 9 percent of scraps set aside for composting are thrown into the regular trash. Based on self-reports from the survey data, below are the estimates for composting in Vermont.

Estimates of extent of residential food scraps being composted in Vermont (in pounds)

Number of HHs in Vermont	277,090
Est. of composting HHs (79%)	218,901
Est. avg composted lbs per week by composting HHs	15.24
Est. avg composted lbs per week for all HHs	12.04
Est. avg composted lbs per year for all HHs	626
Est. lbs composted per year by residents in Vermont	173,503,201

While this is the most precise estimate of the level of composting that we can gather from the data in the survey, there are reasons to suspect that the estimates are higher than the true value. Two factors that would suggest the estimate is high are the time of year of the survey and social desirability (the tendency for respondents to over-report socially desirable behavior).

First, additional survey questions make it clear that Vermonters do not compost at the same level throughout the year; 74 percent say that their composting habits do not vary throughout the year. However, 22 percent say that they compost less during the winter months and 4 percent say that they compost less during the summer months. Based on this information, and the fact that the survey was conducted in the fall when composting is easier, we should expect our estimates to be higher than the true value, but we don't have a precise estimate of how much higher.

Lastly, while any estimate of one's behavior will have error, we could expect the error in composting estimates to be positively biased; in other words, we can expect that respondents are more likely to over-report composting than to under-report due to the social pressure to favor environmentally responsible behavior. This is compounded by the fact that the composting of food waste is now legally required in the state and respondents may not be as willing to admit that they are engaging in behavior that violates state law. Unfortunately, however, we do not have a measurement of the size of the social desirability error.

Respondents were asked to enumerate what percentage of the food set aside last week for composting in their household was managed in each of the following ways. Nearly half (48%) of respondents say that three-quarters or more of their household's food set aside last week for composting was placed in their own compost pile or composter. Less than one-fifth say that any portion of the food their household set aside for composting last week was dropped off at a transfer station or other collection point specifically for composting (19%), was picked up by a waste hauler specifically for composting (18%), was fed to pets (15%), or was fed to farm animals or livestock (13%). A larger proportion (42%) say that they threw at least some of their food waste in the regular trash in the past week, but most who say their household did so at all say that only 1-24% of their food waste was disposed this way.

Overall, respondents indicate that 53% of their food waste set aside for composting last week was placed in their own compost pile or composter, 16% was picked up by a waste hauler specifically for composting, 14% was dropped off at a transfer station or other collection point specifically for composting, 9% was thrown in the regular trash, 6% was fed to farm animals or livestock, and 2% was fed to pets.

Figure 14a: Thinking about all of the food waste set aside for composting by your household last week, please estimate approximately what percentage was dealt with in each of the following ways

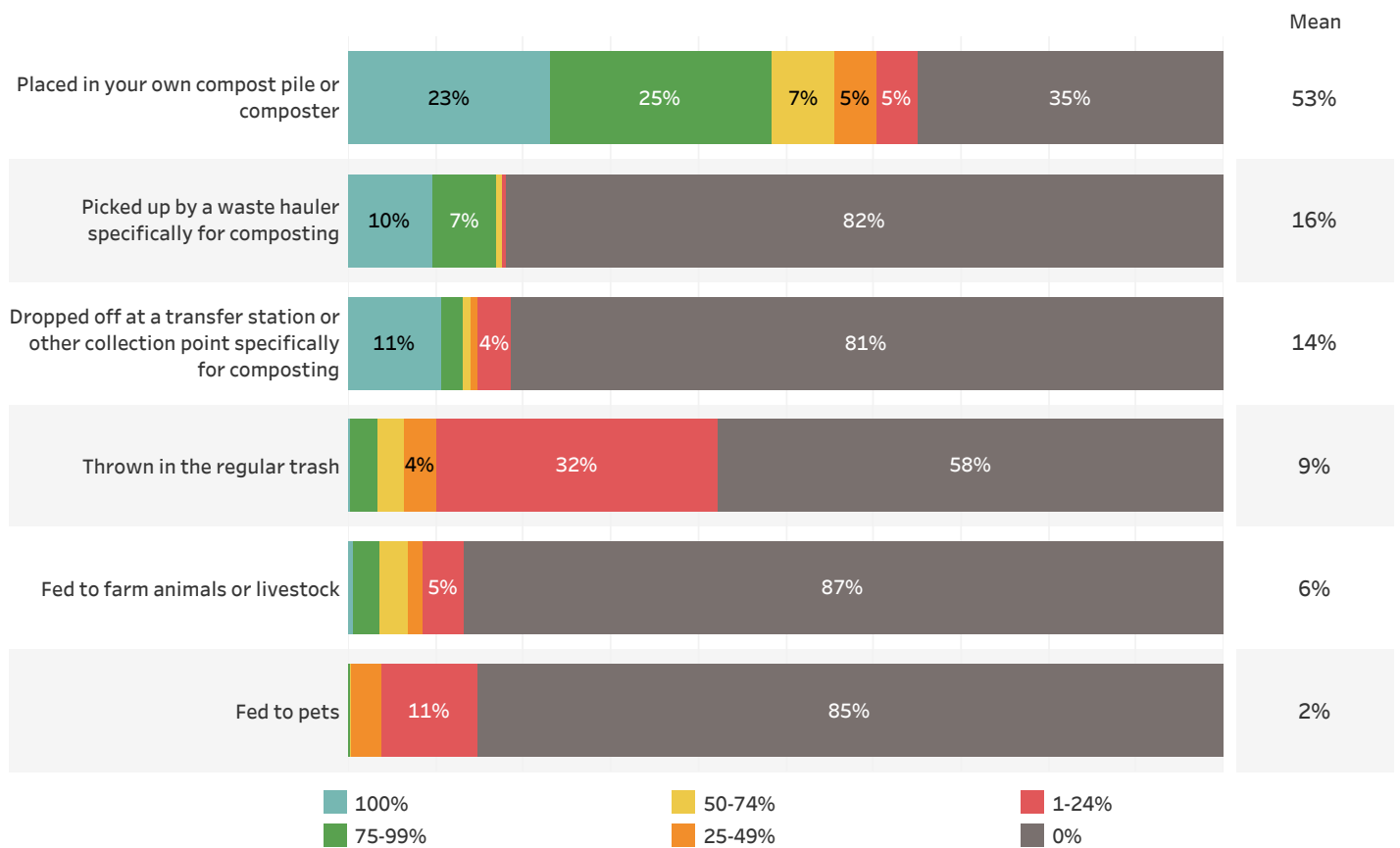

Respondents who do not live in Chittenden County are more likely to say they placed food waste in their own compost pile or composter or fed it to farm animals or livestock in the past week. Respondents in Central Vermont are more likely than others to say they put food waste in the regular trash in the past week. Respondents who live in Chittenden County are more likely than others to say they dropped off food waste at a transfer station or had it picked up by a waste hauler in the past week. Respondents in the Northern Counties are more likely than others to say they fed food waste to pets in the past week.

Figure 14b: What household did with food waste last week - Composting households - by Region

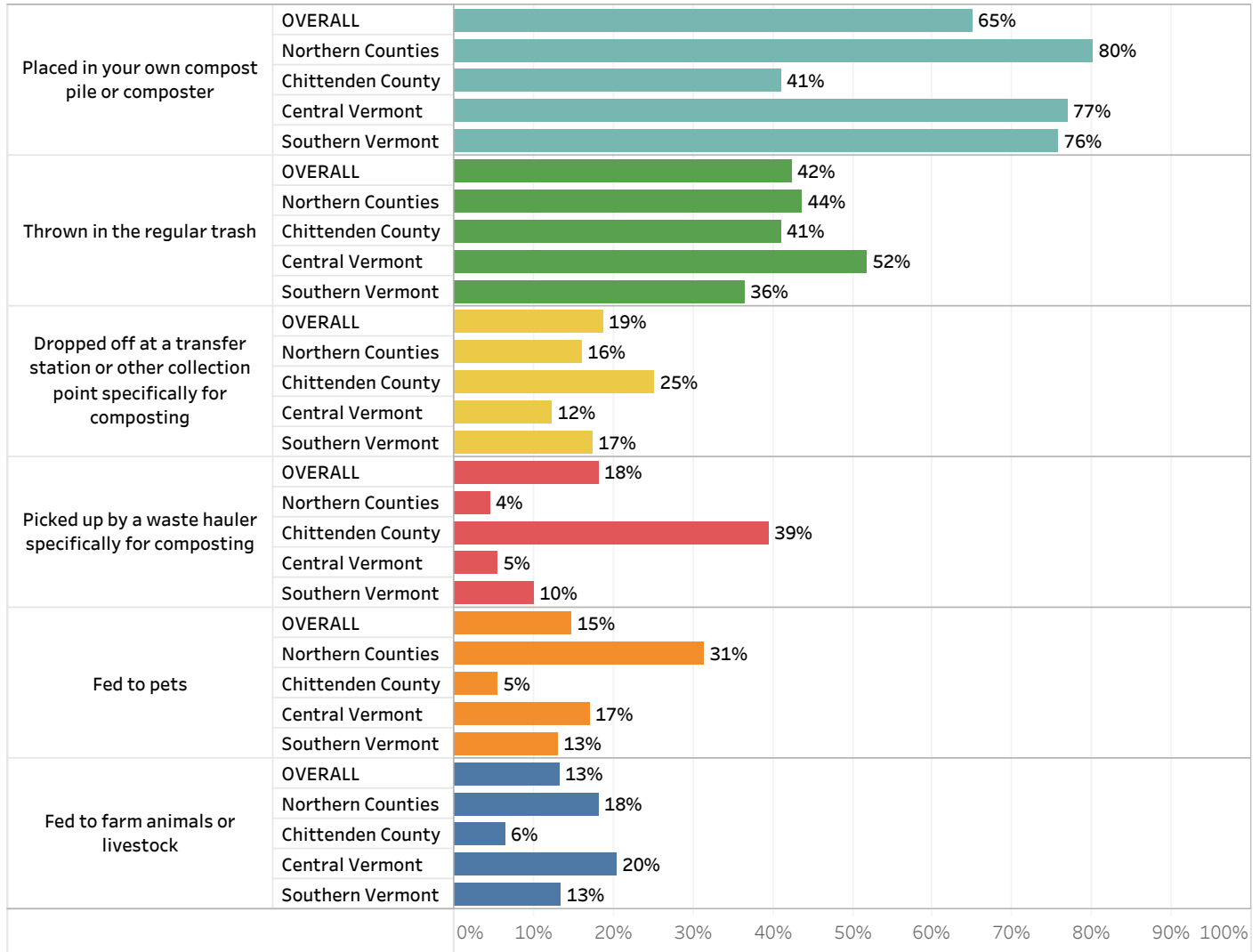

Older respondents are more likely than others to say they placed food waste in their own compost pile or composter in the past week. Younger respondents are more likely than others to say they put food waste in the regular trash in the past week. Respondents between the ages of 35 and 49 are more likely than others to say they fed food waste to pets or had it picked up by a waste hauler in the past week. Respondents between the ages of 50 and 64 are more likely than others to say they fed food waste to farm animals or livestock.

Figure 14c: What household did with food waste last week - Composting households - by Age

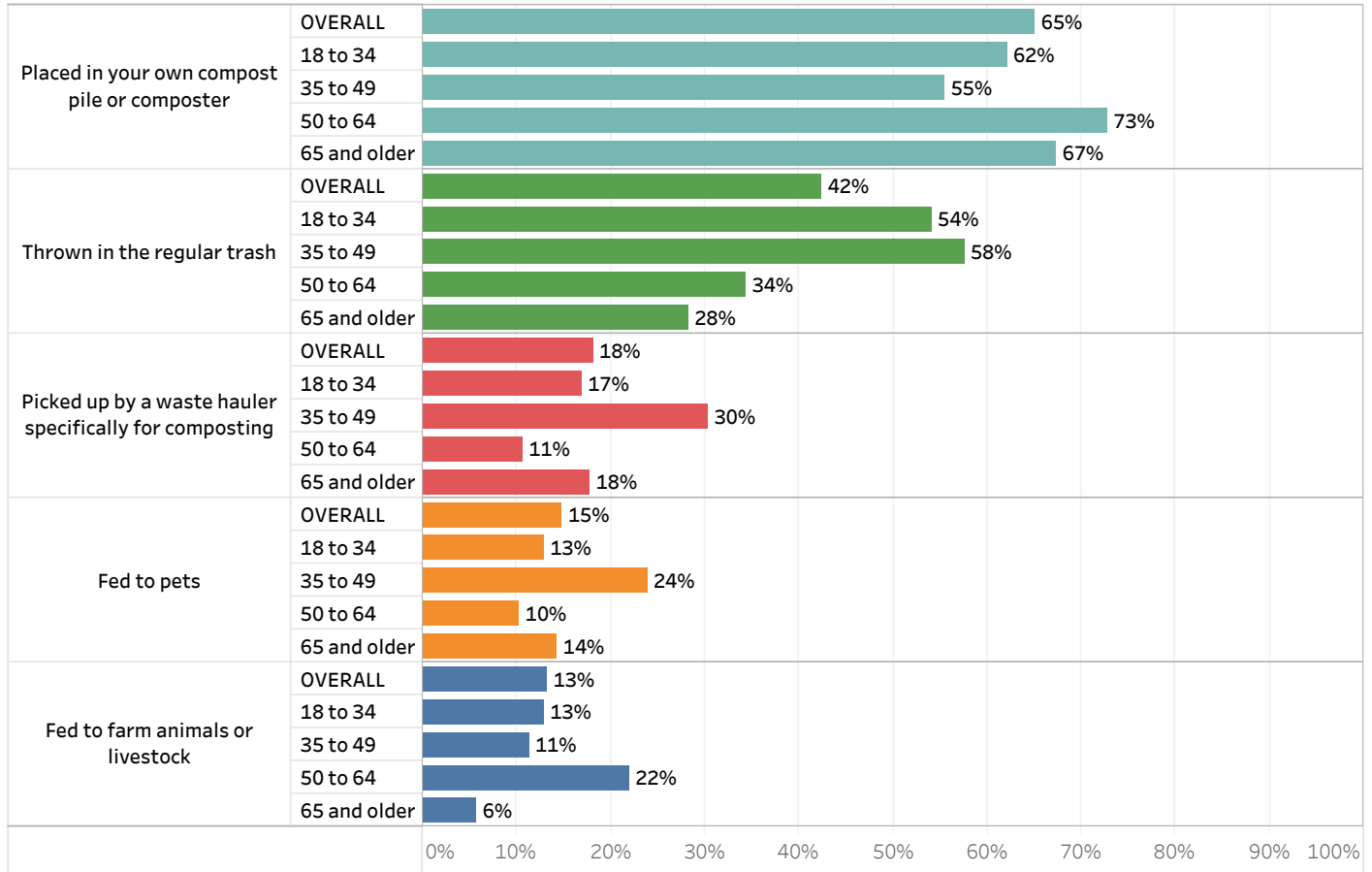

Respondents with higher levels of education are more likely than others to say they placed food waste in their own compost pile or composter within the past week. Respondents with lower levels of education are more likely than others to say they had food waste picked up by a waste hauler within the past week.

Figure 14d: What household did with food waste last week - Composting households - by Level of Education

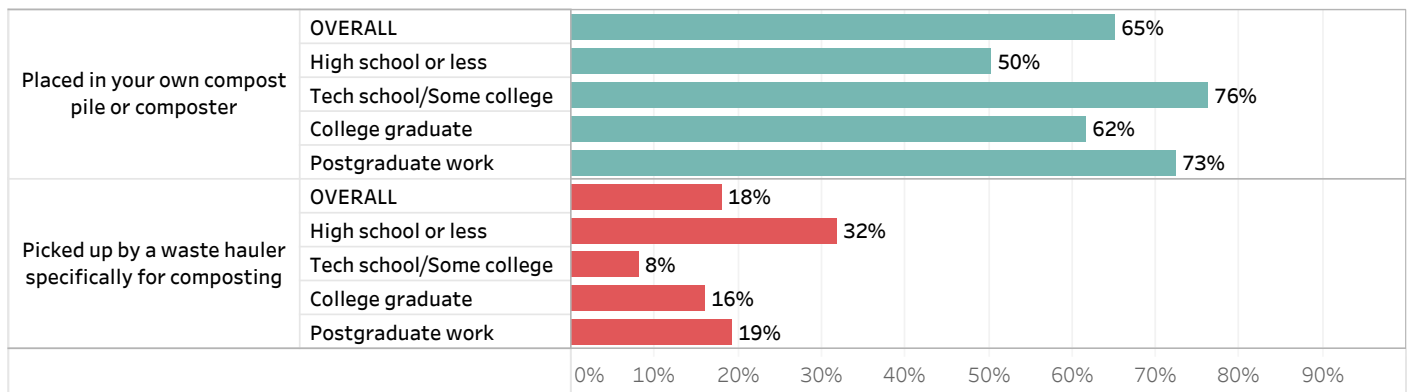

Respondents who own their home are more likely than others to have placed food waste in their own compost pile or composter in the past week. Respondents who rent their home are more likely than others to have thrown food waste in the regular trash, dropped it off at a transfer station, or had it picked up by a waste hauler in the past week.

Figure 14e: What household did with food waste last week - Composting households - by Homeowner Status

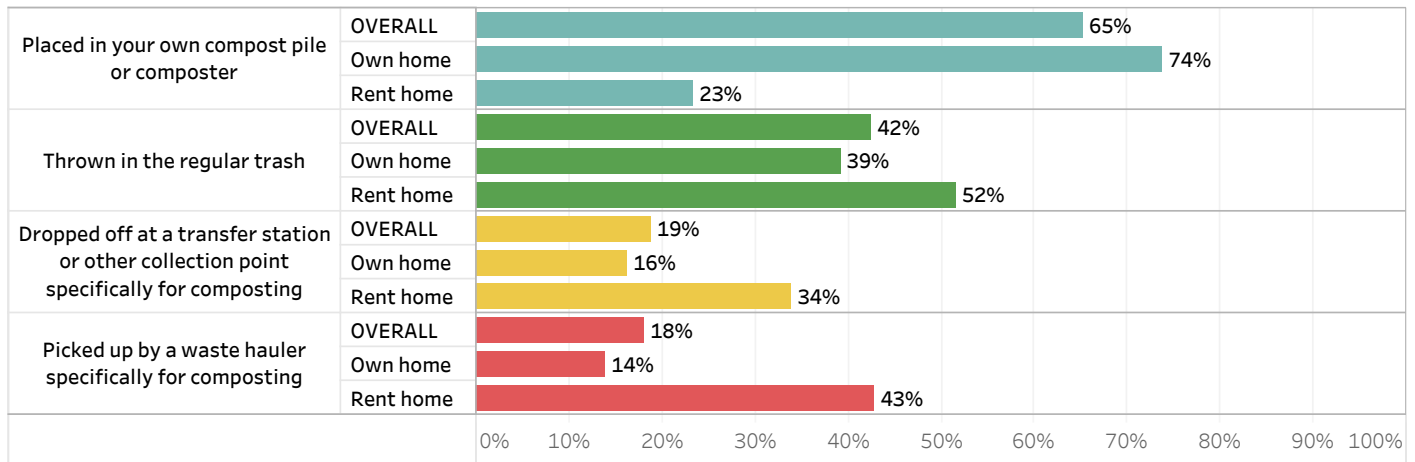

Respondents who live in open country or on a farm are more likely than others to say they placed food waste in their own compost pile or composter or that they fed food waste to pets, farm animals, or livestock within the past week. Respondents who live in an urban or suburban setting are more likely than others to say they had food waste picked up by a waste hauler in the past week, while those who live in a suburban setting are more likely than others to say they dropped off food waste at a transfer station in the past week.

Figure 14f: What household did with food waste last week - Composting households - by Home Location

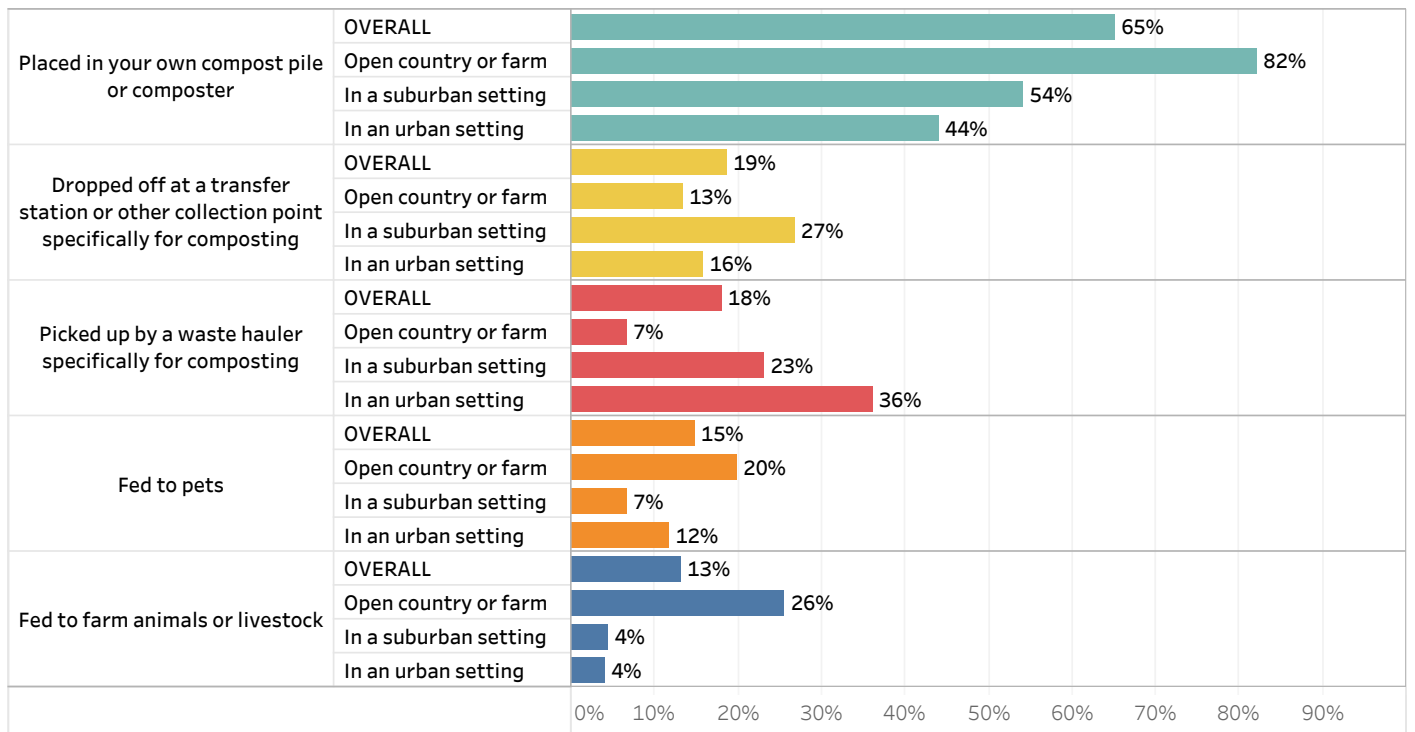

Respondents who live in a detached single-family home are more likely than others to say they placed food waste in their own compost pile or composter in the past week. Respondents who live in an apartment or duplex are more likely than others to say they put food waste in the regular trash or dropped it off at a transfer station in the past week. Respondents who live in an apartment or duplex or in a townhouse or condominium are more likely than others to say they had food waste picked up by a waste hauler.

Figure 14g: What household did with food waste last week - Composting households - by Home Type

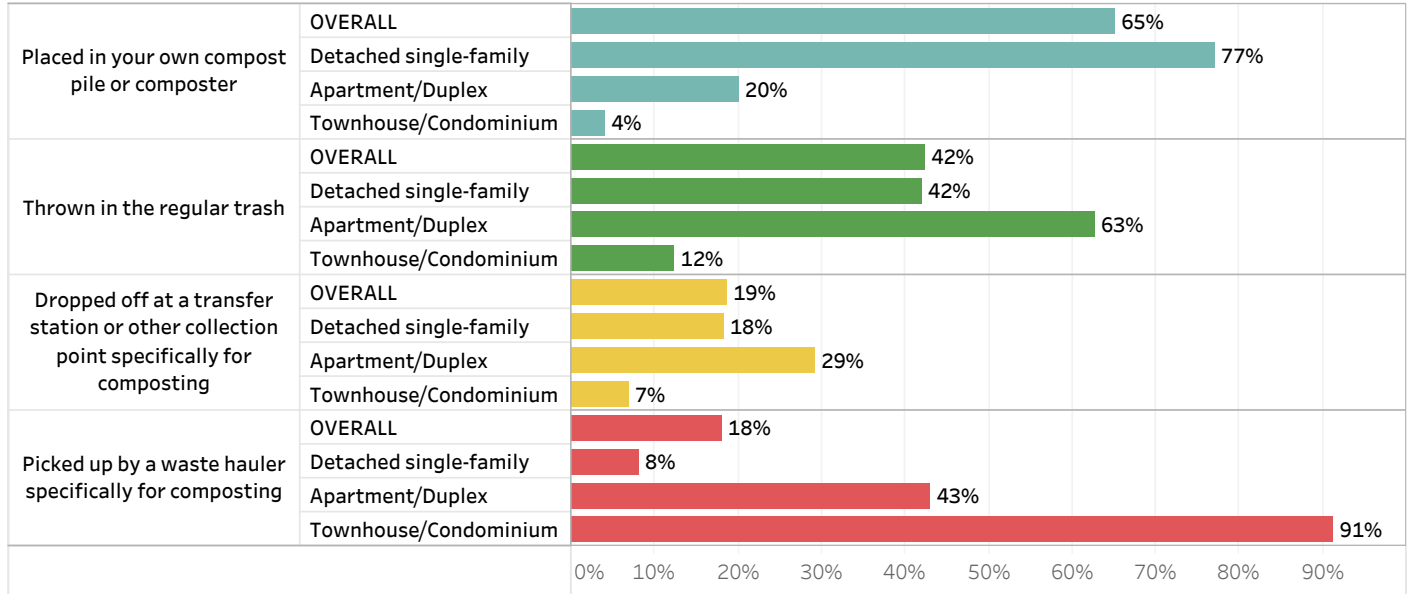

Respondents with a household income between \$45,000 and \$74,999 are more likely than others to say they threw food waste in the regular trash or fed to farm animals or livestock in the past week. Respondents with a household income of less than \$45,000 are more likely than others to say they fed food waste to pets in the past week.

Figure 14h: What household did with food waste last week - composting households - by Household Income

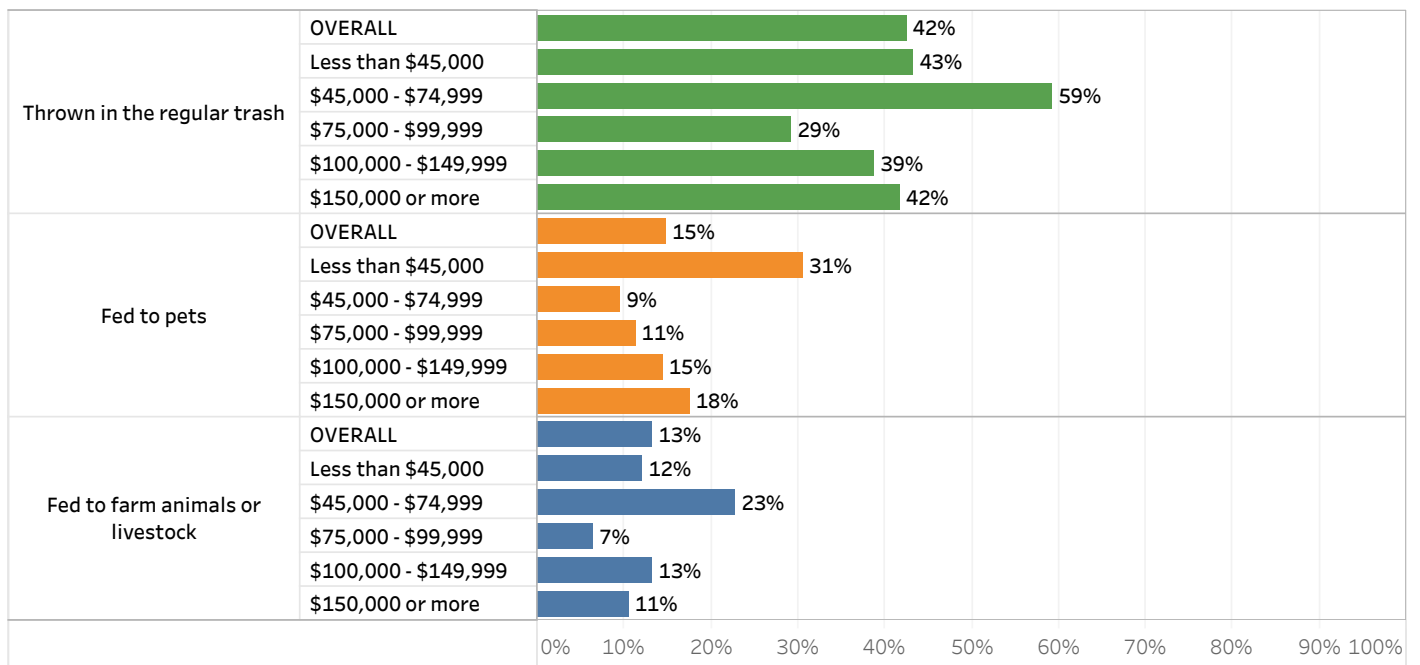

When asked what method or methods they use for composting, 32% say that they put the scraps outside in a pile or heap, 18% put the scraps in a stationary bin outside that they purchased, 14% put the scraps in a stationary bin outside that they built, 13% put the scraps in a unit outside that turns or rotates, and 17% use another method. Twenty-one percent do not have their own composting method at home, and their food scraps are dropped off or hauled.

Figure 15a: Which method(s) do you use for composting? (Select all that apply)

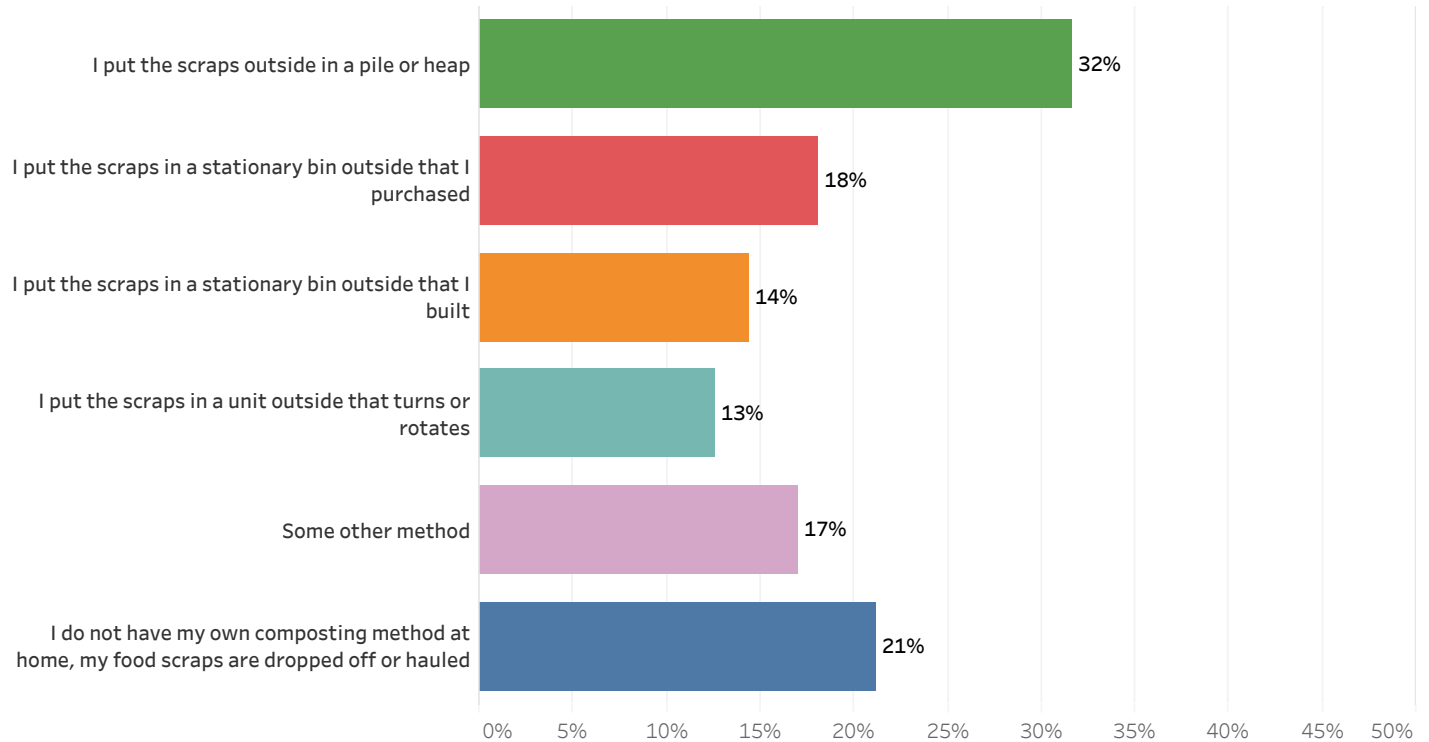

Respondents between the ages of 50 and 64 are more likely than others to say they put the scraps outside in a pile or heap as a composting method. Respondents between the ages of 18 and 34 are more likely than others to say they put the scraps in a stationary bin outside that they built as a composting method. Respondents aged 65 and older are more likely than others to say they put the scraps in a unit outside that turns or rotates as a composting method. Respondents aged 35 to 49 are more likely than others to say they do not have their own composting method at home.

Figure 15b: Methods used for composting - Composting households - by Age

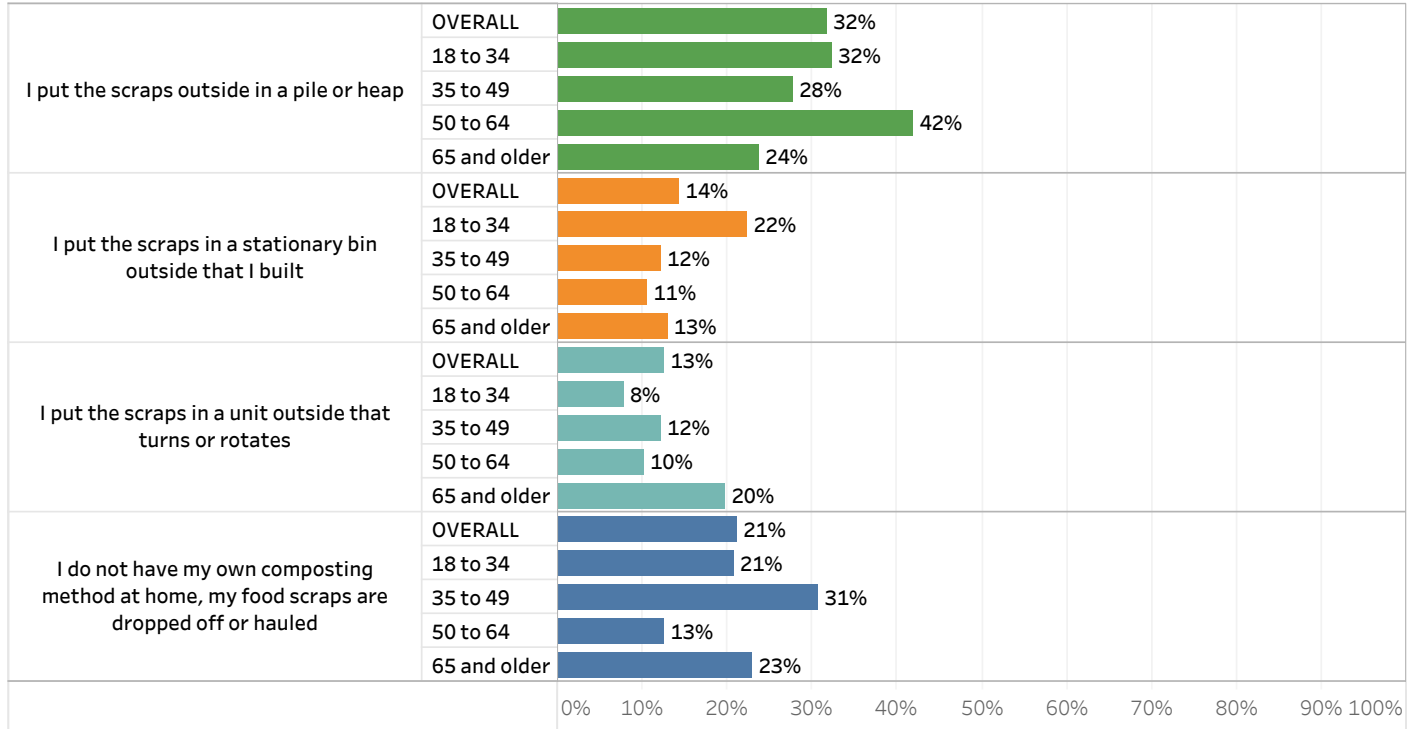

Respondents who own their home are more likely to say they put the scraps in a unit outside that turns or rotates as a composting method. Respondents who rent their home are more likely to say they don't have a composting method at home.

Figure 15c: Methods used for composting - Composting households - by Home Ownership

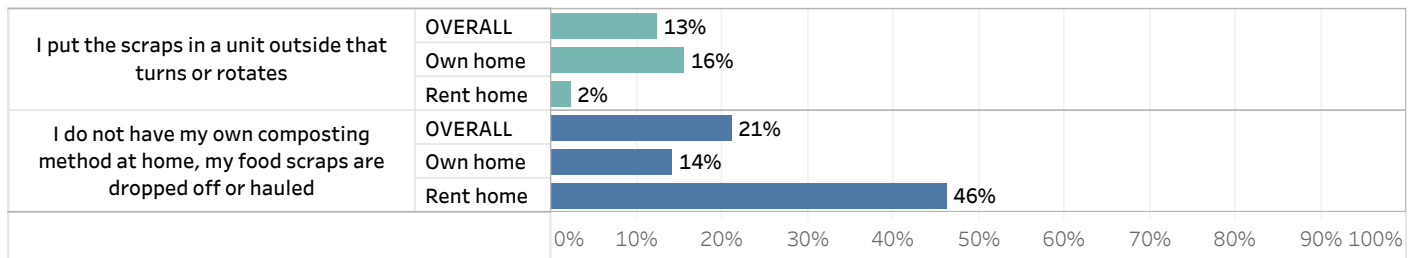

Respondents who live in open country or on a farm are more likely than others to say they put the scraps outside in a pile or heap as a composting method. Respondents who live in an urban or suburban setting are more likely to not have their own composting method at home.

Figure 15d: Methods used for composting - Composting households - by Home Location

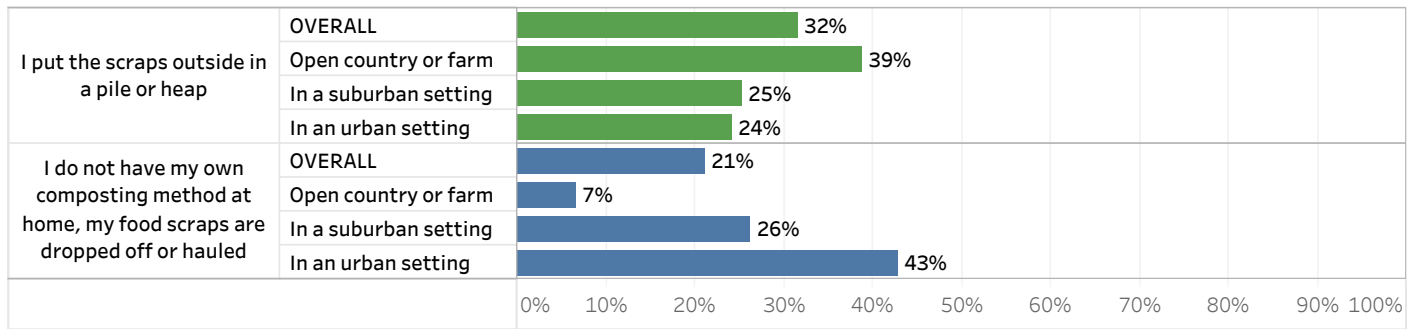

Respondents who live in a detached single-family home are more likely than others to say they put the scraps in a unit outside that turns or rotates as a method of composting. Respondents who live in a detached single-family home or in an apartment or duplex are more likely than others to say they put the scraps outside in a pile or heap as a method of composting. Respondents who live in an apartment or duplex or a townhouse or condominium are more likely than others to not have a composting method at home.

Figure 15e: Methods used for composting - Composting households - by Home Type

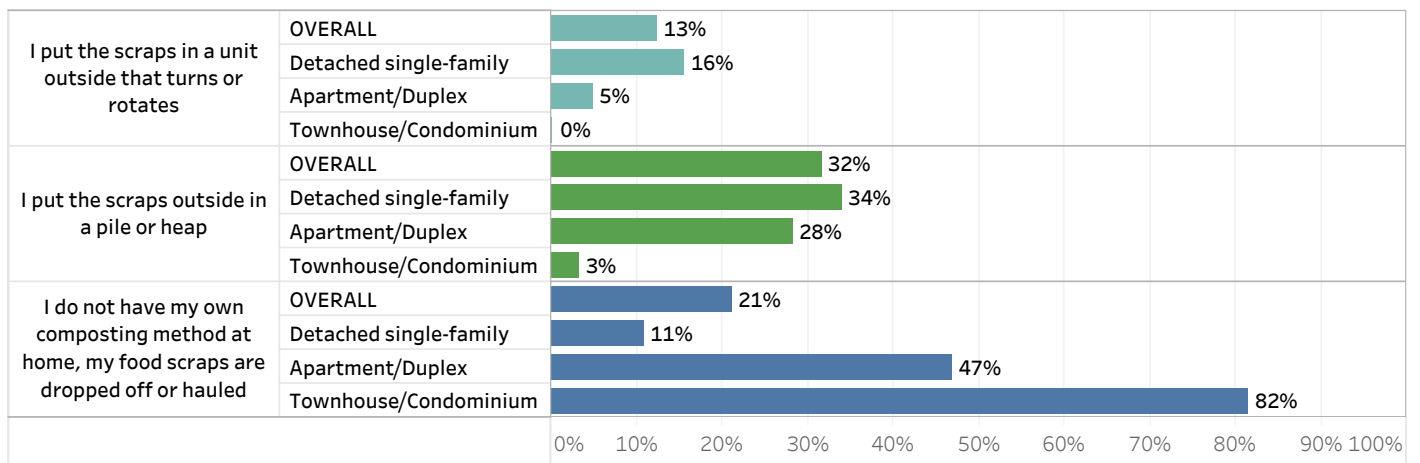

Respondents with lower household incomes are more likely than others to put the scraps outside in a pile or heap as a method of composting or to not have a composting method at home. Respondents with a household income between \$45,000 and \$74,999 are more likely than others to say they put the scraps in a stationary bin outside that they built as a method of composting.

Figure 15f: Methods used for composting - Composting households - by Household Income

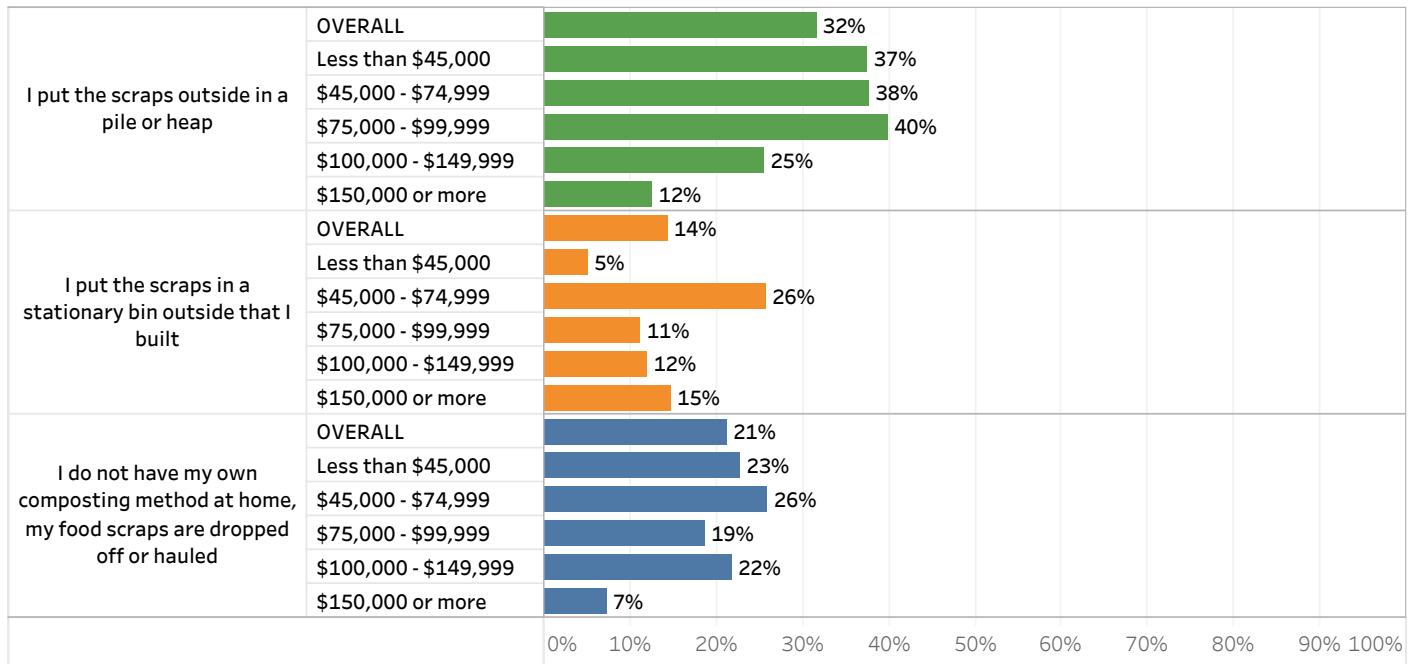

Respondents with lower levels of education are more likely than others to say they put the scraps outside in a pile or heap as a method of composting. Respondents with higher levels of education are more likely than others to say they put the scraps in a stationary bin outside that they purchased as a method of composting.

Figure 15g: Methods used for composting - Composting households - by Level of Education

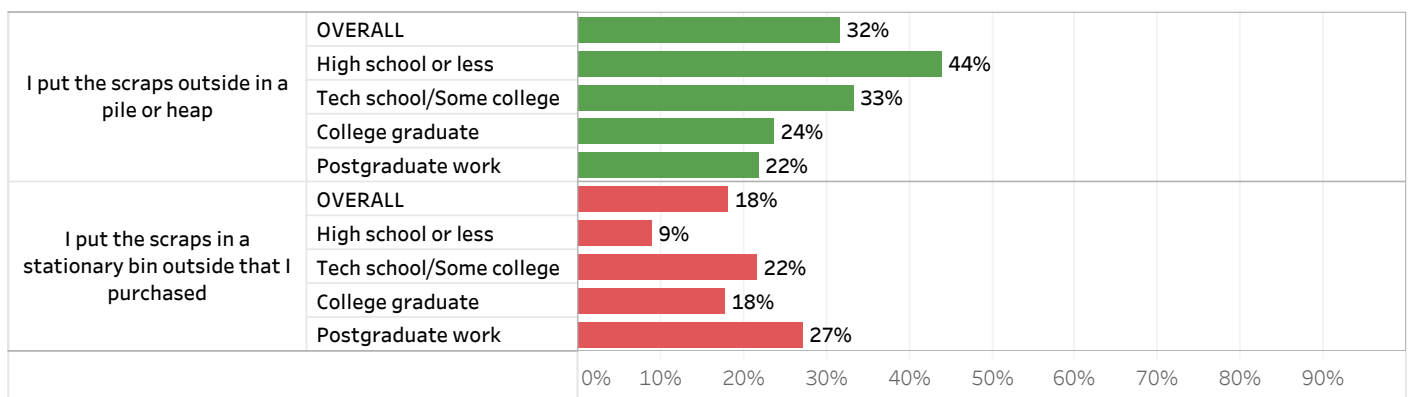

Respondents who live in Southern Vermont are more likely than others to say they put the scraps outside in a pile or heap as a method of composting. Respondents who live in Chittenden County are more likely than others to say they don't have their own composting method at home.

Figure 15h: Methods used for composting - Composting households - by Region

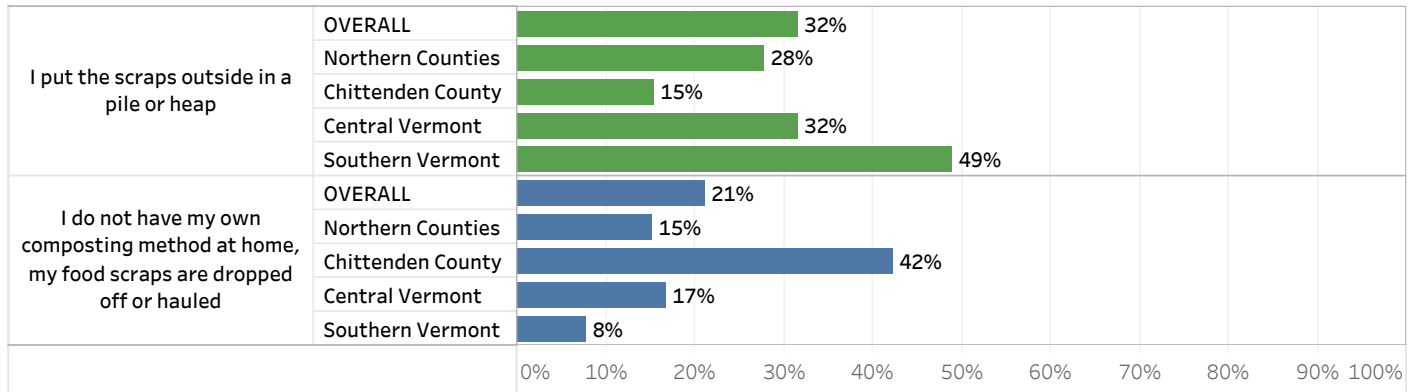

Respondents who have lived in Vermont for a longer period of time are more likely than others to say they put the scraps outside in a pile or heap as a method of composting. Respondents who have lived in Vermont for a shorter period of time are more likely than others to say they put the scraps in a stationary bin outside that they built or that they don't have their own composting method at home.

Figure 15i: Methods used for composting - Composting households - by Years Lived in Vermont

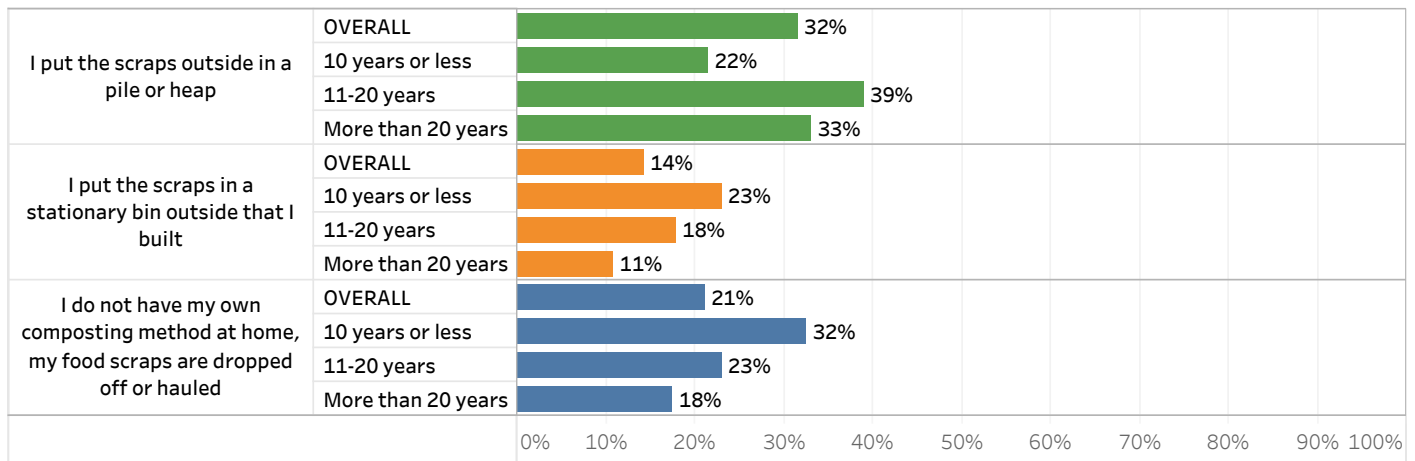

Respondents were asked what percentage of their food scraps they typically set aside for composting during the different seasons of the year. Overall, respondents indicate that they compost between 75% and 80% of their food scraps throughout the year, with the largest amount of composting taking place in the summer. Respondents report composting the least during the winter, when 15% say that they compost none of their food scraps.

Figure 16a: About what percentage of food scraps do you typically compost at each of the following times of the year?

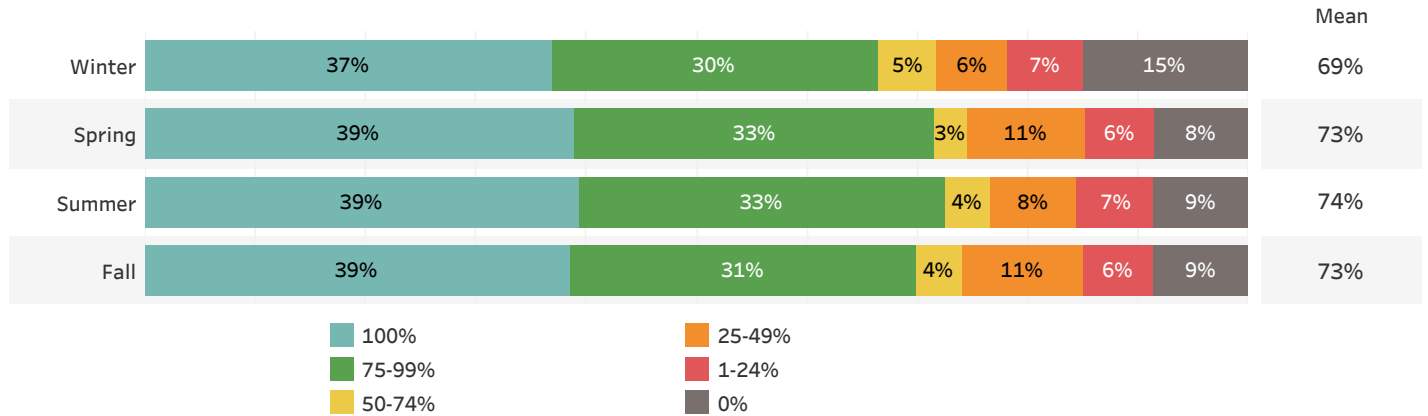

Twenty-two percent of respondents say that they compost more in the summer than they do in winter, three-quarters (74%) say they compost about the same amount in summer as they do in winter, and only 4% say they compost more in the winter than they do in summer.

Figure 16b: Comparison between composting done in summer and winter

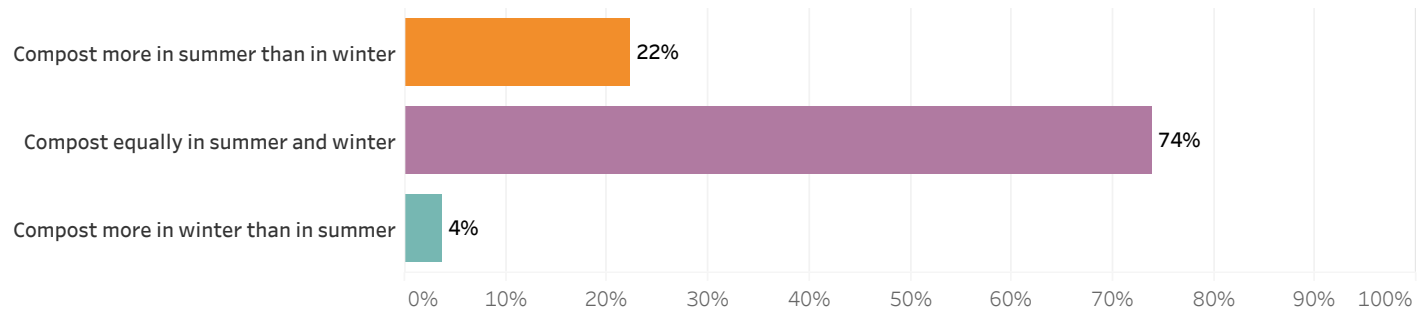

Technical Report

How the Sample Was Selected

The Vermont Compost Questionnaire was a web-based questionnaire administered to Green Mountain State Panel members who are recruited from randomly-selected cell phone numbers and addresses across Vermont. The Green Mountain State Panel is part of an effort by the University of New Hampshire Survey Center to investigate new ways of gathering and understanding the opinion of Vermont residents. Respondents to mail-to-web and text-to-web questionnaires were asked if they wished to participate in further research and asked to provide an email address or phone number. Those who agreed and provided an email address or phone number were added to the panel. Respondents under the age of 18, non-Vermont residents, and seasonal residents who are not registered to vote in Vermont were excluded from joining the panel. For each questionnaire in which they complete, panel members are entered into quarterly drawings to earn rewards, such as gift certificates from statewide and internet companies.

When Data Was Collected

An invitation email or text was sent to Green Mountain State Panel members on September 14th, 2023. Two reminders were sent to non-responders and the data collection closed on the morning of September 18th. Nine hundred and fifty-three (953) Green Mountain State Panel members completed the questionnaire. The response rate for the Vermont Compost Questionnaire is 33%.

Weighting of Data

Data were weighted by respondent gender, age, education, and region of the state to targets from the most recent American Community Survey (ACS) conducted by the U.S. Census Bureau. In addition to potential sampling error, all questionnaires have other potential sources of non-sampling error including question order effects, question wording effects, and non-response. Due to rounding, percentages may not sum to 100%. The number of respondents in each demographic below may not equal the number reported in cross-tabulation tables as some respondents choose not to answer some questions.

Sampling Error

The Vermont Compost Questionnaire, like all questionnaires, is subject to sampling error due to the fact that all residents in the area were not interviewed. For those questions asked of five hundred (500) or so respondents, the error is +/-4.4%. For those questions where fewer than 500 persons responded, the sampling error can be calculated as follows:

$$\text{Sampling Error} = \pm 1.96 \sqrt{\frac{P(1-P)}{N}}$$

Where P is the percentage of responses in the answer category being evaluated and N is the total number of persons answering the particular question.

For example, suppose you had the following distribution of answers to the question, "Should the state spend more money on road repair even if that means higher taxes?" Assume 1,000 respondents answered the question as follows:

YES	47%
NO	48%
DON'T KNOW	5%

The sampling error for the "YES" percentage of 47% would be

$$\pm 1.96 \sqrt{\frac{47(53)}{1000}} = \pm 3.1\%$$

for the "NO" percentage of 48% it would be

$$\pm 1.96 \sqrt{\frac{48(52)}{1000}} = \pm 3.1\%$$

and for the "DON'T KNOW" percentage of 5% it would be

$$\pm 1.96 \sqrt{\frac{5(95)}{1000}} = \pm 1.4\%$$

In this case we would expect the true population figures to be within the following ranges:

YES	43.9% - 50.1% (i.e., 47% ±3.1%)
NO	44.9% - 51.1% (i.e., 48% ±3.1%)
DON'T KNOW	3.6% - 6.4% (i.e., 5% ±1.4%)

The margin of sampling error for the Vermont Compost Questionnaire is +/-3.2 percent.

Design Effect

These MSE's have not been adjusted for design effect. The design effect is 2.2%. To learn more about the Green Mountain State Panel, please visit our website <https://cola.unh.edu/unh-survey-center/projects/states-opinion-project>. For more information about the methodology used in the Vermont Compost Questionnaire, contact Dr. Andrew Smith at (603) 862-2226 or by email at andrew.smith@unh.edu.

Appendix A

Q1: In 2020, the Vermont Universal Recycling Law (Act 148) banned food scraps and other organic waste that decomposes from being disposed of in regular trash and landfills. In your opinion, how informed or uninformed are Vermonters about this change?

		<u>Very informed</u>	<u>Informed</u>	<u>Neither informed nor uninformed</u>	<u>Uninformed</u>	<u>Very uninformed</u>	<u>N</u>
Overall	2023	8%	50%	17%	21%	5%	953
Age	18 to 34	2%	52%	15%	19%	11%	242
	35 to 49	5%	38%	17%	34%	6%	213
	50 to 64	12%	55%	17%	15%	1%	249
	65 and older	11%	52%	19%	18%	1%	248
Children in Household	Children in household	3%	57%	18%	17%	5%	253
	No children in household	10%	47%	17%	22%	5%	698
Employment Status	Employed full-time	5%	54%	18%	18%	4%	492
	Employed part-time	13%	57%	13%	12%	5%	101
	Retired or not working	10%	42%	18%	28%	2%	297
	Unemployed	8%	31%	16%	21%	25%	48
Gender	Men	11%	51%	20%	17%	1%	442
	Women	6%	48%	15%	22%	8%	474
Home Location	Open country or farm	7%	50%	22%	16%	5%	409
	In a suburban setting	10%	49%	17%	21%	4%	367
	In an urban setting	6%	53%	6%	31%	4%	168
Home Type	Detached single-family	9%	51%	17%	19%	4%	666
	Apartment/Duplex	3%	44%	19%	28%	6%	192
	Mobile home	20%	22%	2%	24%	31%	19
	Townhouse/Condominium	10%	59%	8%	22%	2%	46
Household Income	Less than \$45,000	3%	35%	30%	29%	2%	190
	\$45,000 - \$74,999	5%	52%	14%	20%	9%	217
	\$75,000 - \$99,999	15%	61%	7%	16%	1%	124
	\$100,000 - \$149,999	11%	54%	12%	17%	6%	163
	\$150,000 or more	8%	56%	19%	16%	0%	140
Household Size	1 Person HH	7%	42%	19%	26%	6%	144
	2 People HH	7%	52%	17%	20%	4%	437
	3+ People HH	9%	50%	16%	21%	4%	355
Level of Education	High school or less	8%	52%	19%	21%		299
	Tech school/Some college	8%	41%	21%	21%	9%	259
	College graduate	8%	54%	13%	20%	6%	231
	Postgraduate work	6%	52%	13%	24%	5%	163
Own or Rent Home	Own home	9%	53%	16%	17%	4%	694
	Rent home	4%	43%	21%	25%	7%	201
Region of State	Central Vermont	9%	47%	21%	19%	4%	190
	Chittenden County	15%	48%	14%	18%	5%	257
	Northern Counties	5%	48%	19%	27%	2%	214
	Southern Vermont	3%	55%	15%	21%	6%	285
Years Lived in VT	10 years or less	5%	58%	13%	19%	5%	166
	11-20 years	7%	48%	17%	17%	12%	140
	More than 20 years	9%	48%	18%	22%	3%	645

Q2_1: Whether or not you currently compost food scraps, we'd like to know how true each statement below is for you - Composting food scraps is too much work

		<u>Very True</u>	<u>Mostly True</u>	<u>A Little True</u>	<u>Not At All True</u>	<u>Don't Know</u>	<u>N</u>
Overall	2023	11%	11%	37%	40%	1%	953
Age	18 to 34	16%	10%	46%	28%	1%	242
	35 to 49	13%	11%	42%	32%	2%	213
	50 to 64	6%	14%	33%	46%	2%	249
	65 and older	9%	10%	27%	54%		248
Children in Household	Children in household	12%	12%	35%	41%	1%	253
	No children in household	11%	11%	37%	40%	1%	698
Employment Status	Employed full-time	12%	13%	35%	38%	1%	492
	Employed part-time	5%	8%	40%	45%	3%	101
	Retired or not working	10%	8%	35%	47%	0%	297
	Unemployed	20%	16%	44%	21%		48
Gender	Men	11%	17%	35%	37%	0%	442
	Women	11%	6%	37%	44%	2%	474
Home Location	Open country or farm	14%	9%	30%	44%	2%	409
	In a suburban setting	10%	11%	43%	36%	0%	367
	In an urban setting	5%	18%	40%	36%		168
Home Type	Detached single-family	11%	8%	33%	47%	1%	666
	Apartment/Duplex	7%	23%	47%	23%	0%	192
	Mobile home	42%	22%	26%	10%		19
	Townhouse/Condominium	4%	3%	45%	49%		46
Household Income	Less than \$45,000	15%	9%	36%	39%	1%	190
	\$45,000 - \$74,999	12%	19%	40%	29%	0%	217
	\$75,000 - \$99,999	4%	14%	27%	54%	2%	124
	\$100,000 - \$149,999	8%	6%	43%	43%	0%	163
	\$150,000 or more	17%	4%	39%	39%	0%	140
Household Size	1 Person HH	18%	10%	40%	32%	0%	144
	2 People HH	9%	13%	31%	46%	1%	437
	3+ People HH	11%	8%	42%	38%	1%	355
Level of Education	High school or less	6%	17%	38%	39%		299
	Tech school/Some college	22%	10%	32%	33%	3%	259
	College graduate	9%	5%	42%	44%	0%	231
	Postgraduate work	6%	10%	34%	49%	1%	163
Own or Rent Home	Own home	12%	9%	31%	47%	1%	694
	Rent home	10%	18%	48%	24%	0%	201
Region of State	Central Vermont	12%	20%	29%	38%	0%	190
	Chittenden County	8%	5%	43%	44%	0%	257
	Northern Counties	16%	4%	42%	37%	1%	214
	Southern Vermont	9%	16%	32%	42%	1%	285
Years Lived in VT	10 years or less	3%	8%	44%	41%	3%	166
	11-20 years	13%	11%	29%	44%	3%	140
	More than 20 years	13%	12%	36%	39%	0%	645

Q2_2: Whether or not you currently compost food scraps, we'd like to know how true each statement below is for you - Composting food scraps is good for the environment

		<u>Very True</u>	<u>Mostly True</u>	<u>A Little True</u>	<u>Not At All True</u>	<u>Don't Know</u>	<u>N</u>
Overall	2023	58%	24%	11%	4%	3%	953
Age	18 to 34	67%	19%	13%	2%		242
	35 to 49	59%	22%	9%	2%	9%	213
	50 to 64	56%	23%	10%	10%	1%	249
	65 and older	49%	32%	14%	2%	3%	248
Children in Household	Children in household	50%	32%	7%	6%	5%	253
	No children in household	61%	21%	13%	3%	2%	698
Employment Status	Employed full-time	56%	24%	11%	4%	4%	492
	Employed part-time	67%	17%	12%	4%	0%	101
	Retired or not working	52%	30%	14%	1%	3%	297
	Unemployed	75%	7%	3%	15%		48
Gender	Men	42%	29%	20%	6%	4%	442
	Women	71%	20%	4%	2%	3%	474
Home Location	Open country or farm	57%	21%	12%	5%	5%	408
	In a suburban setting	53%	32%	9%	4%	2%	367
	In an urban setting	68%	14%	16%	1%	0%	168
Home Type	Detached single-family	58%	26%	10%	4%	2%	666
	Apartment/Duplex	49%	26%	16%	6%	3%	192
	Mobile home	44%	3%	49%	3%		18
	Townhouse/Condominium	81%	7%	0%		12%	46
Household Income	Less than \$45,000	49%	39%	7%	3%	2%	190
	\$45,000 - \$74,999	59%	15%	21%	3%	2%	217
	\$75,000 - \$99,999	52%	31%	4%	12%	0%	124
	\$100,000 - \$149,999	65%	15%	12%	2%	6%	163
	\$150,000 or more	64%	26%	7%	2%	1%	140
Household Size	1 Person HH	68%	12%	8%	7%	6%	144
	2 People HH	52%	24%	17%	2%	4%	437
	3+ People HH	58%	29%	6%	5%	2%	355
Level of Education	High school or less	34%	34%	22%	5%	6%	299
	Tech school/Some college	67%	20%	8%	3%	3%	259
	College graduate	67%	20%	7%	5%	1%	231
	Postgraduate work	74%	18%	4%	2%	2%	163
Own or Rent Home	Own home	56%	25%	12%	4%	3%	694
	Rent home	57%	18%	14%	5%	5%	201
Region of State	Central Vermont	58%	17%	13%	7%	4%	190
	Chittenden County	70%	16%	9%	4%	2%	257
	Northern Counties	45%	46%	8%	1%	0%	214
	Southern Vermont	56%	19%	15%	4%	6%	285
Years Lived in VT	10 years or less	72%	20%	4%	2%	3%	165
	11-20 years	68%	13%	2%	12%	6%	140
	More than 20 years	52%	27%	16%	3%	3%	645

Q2_3: Whether or not you currently compost food scraps, we'd like to know how true each statement below is for you - Compost piles and bins attract pests like insects and vermin

		<u>Very True</u>	<u>Mostly True</u>	<u>A Little True</u>	<u>Not At All True</u>	<u>Don't Know</u>	<u>N</u>
Overall	2023	31%	26%	35%	6%	2%	953
Age	18 to 34	27%	27%	37%	8%	2%	242
	35 to 49	41%	26%	29%	2%	2%	213
	50 to 64	31%	25%	39%	4%	1%	249
	65 and older	25%	26%	35%	10%	4%	248
Children in Household	Children in household	44%	19%	35%	2%		253
	No children in household	26%	28%	35%	8%	3%	698
Employment Status	Employed full-time	33%	23%	37%	3%	3%	492
	Employed part-time	23%	25%	47%	5%		101
	Retired or not working	28%	31%	30%	9%	3%	297
	Unemployed	27%	22%	27%	24%	0%	48
Gender	Men	34%	31%	30%	4%	1%	442
	Women	29%	21%	39%	8%	4%	474
Home Location	Open country or farm	32%	29%	31%	6%	2%	409
	In a suburban setting	37%	22%	35%	2%	4%	367
	In an urban setting	17%	26%	47%	11%	0%	168
Home Type	Detached single-family	32%	24%	37%	6%	1%	666
	Apartment/Duplex	27%	31%	30%	8%	3%	192
	Mobile home	67%	7%	24%	1%	1%	19
	Townhouse/Condominium	11%	33%	37%	3%	16%	46
Household Income	Less than \$45,000	36%	23%	26%	14%	1%	190
	\$45,000 - \$74,999	27%	32%	36%	3%	3%	217
	\$75,000 - \$99,999	24%	19%	53%	4%	0%	124
	\$100,000 - \$149,999	32%	24%	34%	5%	5%	163
	\$150,000 or more	35%	26%	34%	5%		140
Household Size	1 Person HH	24%	29%	26%	18%	4%	144
	2 People HH	27%	24%	40%	6%	3%	437
	3+ People HH	37%	27%	34%	2%		355
Level of Education	High school or less	33%	34%	25%	5%	2%	299
	Tech school/Some college	33%	23%	36%	6%	3%	259
	College graduate	29%	23%	39%	7%	2%	231
	Postgraduate work	25%	18%	48%	7%	3%	163
Own or Rent Home	Own home	34%	22%	37%	5%	2%	694
	Rent home	19%	33%	36%	9%	3%	201
Region of State	Central Vermont	29%	29%	35%	7%	0%	190
	Chittenden County	25%	33%	31%	5%	5%	257
	Northern Counties	42%	19%	31%	7%	1%	214
	Southern Vermont	29%	21%	43%	6%	1%	285
Years Lived in VT	10 years or less	12%	30%	40%	13%	6%	166
	11-20 years	40%	18%	38%	1%	3%	140
	More than 20 years	33%	26%	33%	6%	1%	645

Q2_4: Whether or not you currently compost food scraps, we'd like to know how true each statement below is for you - Composting food scraps is just not worth the effort

		<u>Very True</u>	<u>Mostly True</u>	<u>A Little True</u>	<u>Not At All True</u>	<u>Don't Know</u>	<u>N</u>
Overall	2023	15%	9%	16%	57%	4%	953
Age	18 to 34	25%	3%	12%	59%	1%	242
	35 to 49	15%	10%	28%	38%	10%	213
	50 to 64	14%	9%	14%	62%	1%	249
	65 and older	5%	12%	12%	66%	4%	248
Children in Household	Children in household	15%	6%	22%	50%	7%	253
	No children in household	14%	10%	14%	60%	2%	698
Employment Status	Employed full-time	19%	7%	17%	52%	4%	492
	Employed part-time	7%	9%	7%	76%	0%	101
	Retired or not working	10%	12%	16%	57%	5%	297
	Unemployed	15%	5%	30%	50%		48
Gender	Men	23%	11%	15%	47%	4%	442
	Women	7%	6%	19%	64%	4%	474
Home Location	Open country or farm	15%	9%	14%	56%	6%	409
	In a suburban setting	15%	10%	16%	57%	2%	367
	In an urban setting	14%	4%	24%	55%	3%	168
Home Type	Detached single-family	9%	10%	16%	62%	4%	666
	Apartment/Duplex	34%	9%	19%	36%	2%	192
	Mobile home	59%	1%	18%	17%	5%	19
	Townhouse/Condominium		3%	23%	75%		46
Household Income	Less than \$45,000	22%	13%	8%	53%	5%	190
	\$45,000 - \$74,999	19%	11%	22%	47%	1%	217
	\$75,000 - \$99,999	13%	2%	11%	72%	2%	124
	\$100,000 - \$149,999	4%	8%	25%	62%	2%	163
	\$150,000 or more	18%	4%	19%	58%	1%	140
Household Size	1 Person HH	16%	10%	12%	60%	2%	144
	2 People HH	16%	11%	12%	57%	4%	437
	3+ People HH	12%	5%	24%	55%	3%	355
Level of Education	High school or less	22%	12%	14%	48%	5%	299
	Tech school/Some college	19%	8%	18%	50%	5%	259
	College graduate	7%	9%	15%	67%	2%	231
	Postgraduate work	4%	4%	20%	69%	3%	163
Own or Rent Home	Own home	11%	10%	16%	60%	4%	694
	Rent home	25%	7%	19%	45%	4%	201
Region of State	Central Vermont	16%	13%	17%	49%	5%	190
	Chittenden County	6%	8%	20%	64%	2%	257
	Northern Counties	26%	6%	15%	53%	0%	214
	Southern Vermont	13%	9%	13%	60%	5%	285
Years Lived in VT	10 years or less	3%	6%	17%	71%	3%	166
	11-20 years	9%	6%	12%	61%	11%	140
	More than 20 years	19%	9%	17%	53%	2%	645

Q2_5: Whether or not you currently compost food scraps, we'd like to know how true each statement below is for you - Vermonters should compost food scraps

		<u>Very True</u>	<u>Mostly True</u>	<u>A Little True</u>	<u>Not At All True</u>	<u>Don't Know</u>	<u>N</u>
Overall	2023	48%	20%	17%	9%	6%	953
Age	18 to 34	57%	20%	12%	8%	2%	242
	35 to 49	39%	18%	19%	11%	12%	213
	50 to 64	51%	19%	19%	10%	1%	249
	65 and older	45%	24%	17%	7%	8%	248
Children in Household	Children in household	48%	21%	8%	15%	9%	253
	No children in household	49%	20%	20%	7%	5%	698
Employment Status	Employed full-time	48%	18%	17%	11%	7%	492
	Employed part-time	57%	22%	17%	3%	0%	101
	Retired or not working	42%	24%	21%	7%	6%	297
	Unemployed	58%	23%	2%	15%	3%	48
Gender	Men	34%	20%	25%	14%	7%	442
	Women	61%	20%	11%	3%	5%	473
Home Location	Open country or farm	42%	21%	20%	9%	7%	409
	In a suburban setting	52%	18%	13%	11%	5%	367
	In an urban setting	52%	23%	17%	5%	3%	168
Home Type	Detached single-family	48%	22%	14%	10%	6%	666
	Apartment/Duplex	43%	19%	30%	6%	2%	192
	Mobile home	15%	25%	40%	20%		19
	Townhouse/Condominium	70%	8%	2%	4%	16%	46
Household Income	Less than \$45,000	41%	23%	21%	6%	8%	190
	\$45,000 - \$74,999	41%	24%	28%	2%	5%	217
	\$75,000 - \$99,999	56%	23%	9%	10%	3%	124
	\$100,000 - \$149,999	57%	19%	14%	4%	6%	163
	\$150,000 or more	49%	15%	11%	23%	2%	140
Household Size	1 Person HH	58%	16%	12%	9%	6%	144
	2 People HH	45%	17%	25%	7%	6%	436
	3+ People HH	48%	27%	10%	11%	5%	355
Level of Education	High school or less	33%	19%	26%	13%	10%	299
	Tech school/Some college	47%	23%	13%	12%	5%	259
	College graduate	61%	19%	13%	4%	3%	231
	Postgraduate work	61%	21%	11%	3%	3%	162
Own or Rent Home	Own home	48%	21%	16%	10%	6%	693
	Rent home	46%	22%	17%	7%	7%	201
Region of State	Central Vermont	49%	16%	21%	11%	4%	190
	Chittenden County	57%	23%	12%	6%	2%	256
	Northern Counties	33%	27%	17%	17%	6%	214
	Southern Vermont	53%	15%	19%	5%	8%	285
Years Lived in VT	10 years or less	68%	18%	9%	2%	2%	166
	11-20 years	54%	16%	9%	9%	11%	140
	More than 20 years	42%	21%	20%	10%	6%	644

Q2_6: Whether or not you currently compost food scraps, we'd like to know how true each statement below is for you - I don't have the space to compost food scraps

		<u>Very True</u>	<u>Mostly True</u>	<u>A Little True</u>	<u>Not At All True</u>	<u>Don't Know</u>	<u>N</u>
Overall	2023	18%	10%	14%	57%	1%	953
Age	18 to 34	35%	9%	10%	46%		242
	35 to 49	22%	14%	22%	41%	1%	213
	50 to 64	4%	11%	14%	70%	2%	249
	65 and older	14%	6%	10%	70%	1%	248
Children in Household	Children in household	28%	5%	14%	51%	1%	253
	No children in household	15%	11%	14%	60%	1%	698
Employment Status	Employed full-time	23%	10%	11%	54%	1%	492
	Employed part-time	7%	13%	19%	61%	0%	101
	Retired or not working	15%	9%	17%	59%	1%	297
	Unemployed	23%	5%	13%	60%		48
Gender	Men	20%	7%	17%	55%	1%	442
	Women	18%	12%	9%	60%	1%	474
Home Location	Open country or farm	12%	6%	12%	69%	1%	409
	In a suburban setting	23%	10%	18%	48%	1%	367
	In an urban setting	24%	18%	10%	48%		168
Home Type	Detached single-family	14%	6%	14%	65%	1%	666
	Apartment/Duplex	33%	22%	14%	30%	1%	192
	Mobile home	44%	7%	14%	34%		19
	Townhouse/Condominium	11%	17%	8%	64%		46
Household Income	Less than \$45,000	27%	6%	16%	50%		190
	\$45,000 - \$74,999	26%	17%	12%	44%	0%	217
	\$75,000 - \$99,999	9%	10%	5%	75%	0%	124
	\$100,000 - \$149,999	4%	13%	12%	71%	1%	163
	\$150,000 or more	25%	4%	12%	56%	3%	140
Household Size	1 Person HH	19%	16%	10%	54%	0%	144
	2 People HH	17%	5%	16%	61%	0%	437
	3+ People HH	20%	13%	12%	53%	2%	355
Level of Education	High school or less	19%	12%	16%	53%		299
	Tech school/Some college	27%	5%	12%	54%	2%	259
	College graduate	12%	13%	14%	60%	1%	231
	Postgraduate work	13%	8%	12%	67%	1%	163
Own or Rent Home	Own home	15%	6%	13%	66%	1%	694
	Rent home	33%	24%	10%	32%	1%	201
Region of State	Central Vermont	19%	8%	13%	57%	3%	190
	Chittenden County	6%	21%	10%	62%	1%	257
	Northern Counties	30%	6%	12%	52%		214
	Southern Vermont	20%	4%	19%	56%	0%	285
Years Lived in VT	10 years or less	16%	6%	16%	61%	1%	166
	11-20 years	11%	11%	17%	61%		140
	More than 20 years	21%	10%	12%	56%	1%	645

Q2_7: Whether or not you currently compost food scraps, we'd like to know how true each statement below is for you - Composting food scraps smell bad

		<u>Very True</u>	<u>Mostly True</u>	<u>A Little True</u>	<u>Not At All True</u>	<u>Don't Know</u>	<u>N</u>
Overall	2023	21%	21%	35%	20%	2%	952
Age	18 to 34	30%	31%	38%	0%	0%	242
	35 to 49	25%	26%	35%	11%	3%	213
	50 to 64	16%	20%	33%	29%	1%	249
	65 and older	15%	9%	36%	38%	2%	248
Children in Household	Children in household	29%	18%	36%	16%	1%	252
	No children in household	19%	23%	35%	22%	2%	698
Employment Status	Employed full-time	24%	21%	37%	16%	2%	492
	Employed part-time	18%	11%	53%	14%	4%	100
	Retired or not working	21%	20%	27%	32%	0%	297
	Unemployed	12%	43%	40%	6%		48
Gender	Men	23%	21%	35%	19%	2%	442
	Women	21%	22%	34%	22%	2%	473
Home Location	Open country or farm	17%	27%	33%	20%	3%	409
	In a suburban setting	30%	11%	40%	19%	0%	367
	In an urban setting	13%	33%	34%	18%	2%	167
Home Type	Detached single-family	19%	18%	37%	25%	2%	665
	Apartment/Duplex	30%	36%	30%	4%	0%	192
	Mobile home	50%	5%	35%	11%		19
	Townhouse/Condominium	15%	8%	46%	31%	0%	46
Household Income	Less than \$45,000	30%	23%	25%	22%	0%	189
	\$45,000 - \$74,999	11%	46%	30%	12%	2%	217
	\$75,000 - \$99,999	27%	7%	36%	30%		124
	\$100,000 - \$149,999	22%	12%	36%	27%	3%	163
	\$150,000 or more	22%	15%	49%	14%	0%	140
Household Size	1 Person HH	18%	28%	30%	23%	1%	144
	2 People HH	19%	19%	39%	22%	1%	437
	3+ People HH	27%	20%	35%	17%	1%	354
Level of Education	High school or less	20%	30%	24%	24%	1%	299
	Tech school/Some college	28%	18%	32%	19%	4%	259
	College graduate	18%	18%	50%	13%	0%	231
	Postgraduate work	18%	15%	41%	25%	1%	162
Own or Rent Home	Own home	20%	17%	36%	25%	2%	693
	Rent home	22%	37%	33%	6%	2%	201
Region of State	Central Vermont	19%	22%	35%	24%	0%	190
	Chittenden County	28%	18%	34%	19%	1%	256
	Northern Counties	27%	17%	35%	19%	1%	214
	Southern Vermont	14%	28%	38%	19%	2%	285
Years Lived in VT	10 years or less	16%	11%	45%	25%	3%	166
	11-20 years	18%	32%	34%	12%	4%	140
	More than 20 years	23%	22%	33%	20%	1%	644

Q2_8: Whether or not you currently compost food scraps, we'd like to know how true each statement below is for you - Composting food scraps is easy

		<u>Very True</u>	<u>Mostly True</u>	<u>A Little True</u>	<u>Not At All True</u>	<u>Don't Know</u>	<u>N</u>
Overall	2023	20%	35%	20%	24%	2%	953
Age	18 to 34	13%	44%	16%	27%		242
	35 to 49	14%	33%	21%	28%	5%	213
	50 to 64	23%	32%	21%	21%	2%	249
	65 and older	27%	30%	22%	20%	0%	248
Children in Household	Children in household	14%	30%	21%	34%	2%	253
	No children in household	22%	36%	20%	20%	2%	698
Employment Status	Employed full-time	18%	35%	20%	24%	3%	492
	Employed part-time	21%	38%	35%	6%	0%	101
	Retired or not working	25%	29%	19%	27%	1%	297
	Unemployed	9%	48%	3%	40%		48
Gender	Men	16%	36%	19%	28%	1%	442
	Women	23%	34%	20%	20%	3%	474
Home Location	Open country or farm	18%	36%	22%	21%	3%	409
	In a suburban setting	18%	26%	23%	33%	1%	367
	In an urban setting	22%	52%	11%	13%	2%	168
Home Type	Detached single-family	22%	33%	22%	21%	2%	666
	Apartment/Duplex	12%	38%	14%	34%	1%	192
	Mobile home	7%	4%	46%	43%		19
	Townhouse/Condominium	28%	25%	25%	22%		46
Household Income	Less than \$45,000	17%	30%	17%	35%	1%	190
	\$45,000 - \$74,999	15%	49%	12%	23%	2%	217
	\$75,000 - \$99,999	25%	33%	24%	17%	0%	124
	\$100,000 - \$149,999	23%	28%	29%	19%	0%	163
	\$150,000 or more	16%	34%	23%	27%	0%	140
Household Size	1 Person HH	22%	36%	18%	23%	1%	144
	2 People HH	23%	33%	20%	24%	1%	437
	3+ People HH	15%	36%	22%	25%	2%	355
Level of Education	High school or less	14%	43%	16%	27%		299
	Tech school/Some college	22%	25%	17%	31%	5%	259
	College graduate	21%	38%	24%	16%	1%	231
	Postgraduate work	24%	31%	27%	16%	2%	163
Own or Rent Home	Own home	22%	33%	23%	21%	2%	694
	Rent home	11%	44%	13%	29%	3%	201
Region of State	Central Vermont	24%	22%	24%	30%	1%	190
	Chittenden County	23%	38%	23%	15%	1%	257
	Northern Counties	19%	26%	15%	40%	1%	214
	Southern Vermont	16%	48%	19%	16%	2%	285
Years Lived in VT	10 years or less	26%	36%	20%	16%	2%	166
	11-20 years	17%	31%	28%	20%	4%	140
	More than 20 years	19%	35%	18%	27%	1%	645

Q3: What does your household do with food waste that comes from eating or preparing food including any scraps, inedible parts, and spoiled or rotten foods? (Select all that apply)

		<u>Feed it to farm animals or livestock</u>	<u>Feed it to pets</u>	<u>Put down the garbage disposal (or down the sink)</u>	<u>Put in with the regular trash</u>	<u>Set it aside for composting in your backyard or own compost pile</u>
Overall	2023	12%	9%	12%	36%	43%
Age	18 to 34	15%	9%	13%	54%	34%
	35 to 49	15%	12%	16%	48%	37%
	50 to 64	11%	6%	11%	23%	58%
	65 and older	7%	7%	10%	23%	44%
Children in Household	Children in household	15%	10%	17%	44%	46%
	No children in household	11%	8%	11%	34%	43%
Employment Status	Employed full-time	16%	9%	14%	43%	45%
	Employed part-time	10%	7%	9%	20%	46%
	Retired or not working	7%	8%	13%	31%	38%
	Unemployed	6%	6%	9%	43%	42%
Gender	Men	15%	9%	14%	40%	35%
	Women	10%	9%	11%	32%	50%
Home Location	Open country or farm	14%	12%	7%	34%	54%
	In a suburban setting	8%	5%	22%	37%	37%
	In an urban setting	14%	4%	4%	43%	30%
Home Type	Detached single-family	12%	10%	12%	30%	56%
	Apartment/Duplex	15%	6%	18%	64%	14%
	Mobile home	0%	13%	9%	70%	10%
	Townhouse/Condominium	4%	3%	4%	28%	4%
Household Income	Less than \$45,000	8%	12%	24%	48%	32%
	\$45,000 - \$74,999	19%	6%	4%	44%	42%
	\$75,000 - \$99,999	4%	6%	13%	30%	51%
	\$100,000 - \$149,999	12%	7%	11%	20%	54%
	\$150,000 or more	16%	18%	12%	37%	41%
Household Size	1 Person HH	5%	14%	3%	34%	34%
	2 People HH	13%	8%	12%	33%	46%
	3+ People HH	13%	8%	17%	42%	43%
Level of Education	High school or less	15%	4%	12%	43%	30%
	Tech school/Some college	11%	14%	16%	39%	47%
	College graduate	9%	9%	8%	32%	47%
	Postgraduate work	11%	9%	13%	27%	56%
Own or Rent Home	Own home	12%	10%	11%	27%	53%
	Rent home	15%	4%	11%	58%	16%
Region of State	Central Vermont	9%	7%	15%	32%	51%
	Chittenden County	4%	4%	7%	33%	31%
	Northern Counties	17%	17%	22%	42%	37%
	Southern Vermont	17%	7%	8%	37%	53%
Years Lived in VT	10 years or less	13%	10%	11%	29%	46%
	11-20 years	5%	6%	15%	43%	53%
	More than 20 years	13%	9%	12%	37%	41%

Q3: What does your household do with food waste that comes from eating or preparing food including any scraps, inedible parts, and spoiled or rotten foods? (Select all that apply)

		<u>Set aside, compost dropped off at transfer station/collection site</u>	<u>Set it aside for composting with the compost being picked up by a waste hauler</u>	<u>Something else</u>	<u>Don't know</u>	<u>N</u>
Overall	2023	13%	12%	13%	1%	953
Age	18 to 34	11%	10%	13%	3%	242
	35 to 49	10%	15%	17%	1%	213
	50 to 64	12%	9%	13%	0%	249
	65 and older	19%	15%	11%	0%	248
Children in Household	Children in household	9%	7%	19%	4%	253
	No children in household	14%	14%	11%	0%	698
Employment Status	Employed full-time	9%	9%	17%	2%	492
	Employed part-time	31%	9%	12%		101
	Retired or not working	16%	20%	9%	0%	297
	Unemployed	5%	3%	12%		48
Gender	Men	14%	8%	17%	2%	442
	Women	12%	16%	10%	1%	474
Home Location	Open country or farm	8%	4%	21%	2%	409
	In a suburban setting	17%	16%	10%		367
	In an urban setting	18%	23%	4%	2%	168
Home Type	Detached single-family	14%	6%	16%	0%	666
	Apartment/Duplex	8%	22%	5%	4%	192
	Mobile home	19%	2%	18%		19
	Townhouse/Condominium	12%	67%	6%	0%	46
Household Income	Less than \$45,000	10%	5%	12%	0%	190
	\$45,000 - \$74,999	11%	15%	12%		217
	\$75,000 - \$99,999	16%	12%	12%		124
	\$100,000 - \$149,999	15%	18%	9%		163
	\$150,000 or more	9%	13%	26%	0%	140
Household Size	1 Person HH	13%	19%	16%		144
	2 People HH	14%	11%	9%	0%	437
	3+ People HH	12%	11%	19%	3%	355
Level of Education	High school or less	11%	14%	16%	3%	299
	Tech school/Some college	6%	6%	14%	1%	259
	College graduate	20%	15%	12%	0%	231
	Postgraduate work	16%	15%	10%	0%	163
Own or Rent Home	Own home	14%	9%	15%	0%	694
	Rent home	14%	26%	6%	1%	201
Region of State	Central Vermont	8%	4%	19%		190
	Chittenden County	20%	34%	9%	1%	257
	Northern Counties	11%	2%	21%	0%	214
	Southern Vermont	11%	6%	7%	3%	285
Years Lived in VT	10 years or less	15%	19%	10%	5%	166
	11-20 years	12%	10%	18%		140
	More than 20 years	13%	11%	13%	0%	645

Q4: Which best describes the size of the container your household uses to set aside items for composting or animal feed?

		About the size of a quart of milk	About the size of a half-gallon of milk	About the size of a gallon of milk	About the size of a 2 gallon bucket	About the size of a large 5 gallon bucket	Some other size	N
Overall	2023	9%	8%	39%	18%	19%	6%	714
Age	18 to 34	14%	4%	42%	11%	24%	4%	168
	35 to 49	7%	7%	37%	31%	9%	9%	149
	50 to 64	8%	12%	38%	20%	16%	6%	202
	65 and older	9%	8%	40%	13%	24%	6%	194
Children in Household	Children in household	10%	4%	42%	24%	11%	9%	174
	No children in household	9%	9%	38%	16%	21%	6%	539
Employment Status	Employed full-time	10%	7%	45%	17%	14%	6%	367
	Employed part-time	3%	2%	46%	12%	23%	14%	84
	Retired or not working	11%	8%	27%	24%	26%	4%	225
	Unemployed	8%	9%	51%	1%	16%	15%	23
Gender	Men	11%	4%	36%	21%	22%	6%	306
	Women	7%	12%	41%	17%	17%	7%	376
Home Location	Open country or farm	15%	10%	39%	17%	11%	9%	299
	In a suburban setting	5%	10%	43%	18%	19%	4%	263
	In an urban setting	5%	1%	36%	22%	29%	6%	143
Home Type	Detached single-family	11%	8%	41%	19%	15%	6%	534
	Apartment/Duplex	7%	3%	33%	21%	30%	6%	112
	Mobile home	11%	4%	10%	28%	43%	3%	8
	Townhouse/Condominium	0%	3%	51%	3%	35%	8%	38
Household Income	Less than \$45,000	16%	12%	34%	15%	17%	6%	104
	\$45,000 - \$74,999	8%	10%	34%	26%	19%	4%	169
	\$75,000 - \$99,999	2%	11%	53%	11%	19%	5%	102
	\$100,000 - \$149,999	7%	4%	42%	12%	22%	13%	144
	\$150,000 or more	15%	5%	32%	28%	13%	7%	107
Household Size	1 Person HH	8%	6%	48%	13%	19%	6%	98
	2 People HH	12%	7%	39%	14%	21%	6%	352
	3+ People HH	6%	8%	36%	27%	16%	7%	248
Level of Education	High school or less	7%	8%	27%	23%	31%	3%	207
	Tech school/Some college	20%	10%	35%	17%	9%	9%	183
	College graduate	6%	7%	49%	14%	18%	6%	189
	Postgraduate work	4%	7%	49%	19%	13%	9%	134
Own or Rent Home	Own home	9%	9%	39%	18%	17%	7%	554
	Rent home	5%	4%	42%	20%	28%	0%	139
Region of State	Central Vermont	15%	7%	36%	19%	16%	6%	127
	Chittenden County	2%	6%	40%	19%	26%	7%	211
	Northern Counties	18%	12%	27%	27%	11%	4%	148
	Southern Vermont	8%	9%	46%	11%	18%	7%	222
Years Lived in VT	10 years or less	15%	9%	41%	9%	19%	7%	133
	11-20 years	7%	4%	54%	19%	7%	9%	103
	More than 20 years	8%	9%	35%	21%	21%	6%	475

Q5: Thinking about last week, about how often did your household empty the container used to set items aside for composting or animal feed?

		<u>More than once per day</u>	<u>Daily</u>	<u>Six times per week</u>	<u>Five times per week</u>	<u>Four times per week</u>
Overall	2023	1%	12%	1%	4%	5%
Age	18 to 34	2%	5%	2%		
	35 to 49	0%	11%	0%	7%	5%
	50 to 64		12%	2%	4%	6%
	65 and older	1%	17%	1%	4%	7%
Children in Household	Children in household	0%	11%	0%	5%	5%
	No children in household	1%	12%	2%	4%	5%
Employment Status	Employed full-time	0%	5%	1%	4%	3%
	Employed part-time		9%	4%	6%	7%
	Retired or not working	0%	19%	1%	3%	7%
	Unemployed	15%	13%	1%	5%	
Gender	Men	0%	8%	2%	3%	5%
	Women	1%	16%	1%	5%	5%
Home Location	Open country or farm	0%	12%	2%	5%	6%
	In a suburban setting	0%	9%	1%	4%	6%
	In an urban setting	2%	11%	1%	2%	0%
Home Type	Detached single-family	0%	11%	2%	4%	6%
	Apartment/Duplex		5%	0%	3%	0%
	Mobile home		26%		3%	
	Townhouse/Condominium	1%	13%	1%	2%	1%
Household Income	Less than \$45,000	3%	27%	3%		1%
	\$45,000 - \$74,999		14%	0%	2%	7%
	\$75,000 - \$99,999	0%	7%	1%	3%	3%
	\$100,000 - \$149,999	0%	8%	3%	7%	8%
	\$150,000 or more	1%	5%		6%	4%
Household Size	1 Person HH	4%	11%	3%		3%
	2 People HH	0%	9%	1%	5%	4%
	3+ People HH	0%	11%	2%	5%	7%
Level of Education	High school or less		15%			2%
	Tech school/Some college	2%	11%	1%	6%	6%
	College graduate	0%	9%	2%	5%	5%
	Postgraduate work	1%	10%	3%	6%	7%
Own or Rent Home	Own home	0%	13%	1%	5%	6%
	Rent home		5%	2%	1%	2%
Region of State	Central Vermont	0%	22%	1%	9%	4%
	Chittenden County	0%	4%	1%	3%	6%
	Northern Counties	2%	14%	1%	3%	4%
	Southern Vermont	0%	12%	3%	3%	5%
Years Lived in VT	10 years or less	0%	18%	2%	1%	4%
	11-20 years		4%	2%	8%	5%
	More than 20 years	1%	12%	1%	4%	5%

Q5: Thinking about last week, about how often did your household empty the container used to set items aside for composting or animal feed?

		<u>Three times per week</u>	<u>Twice per week</u>	<u>Once per week</u>	<u>Less than once per week</u>	<u>Did not set aside items for composting or animal feed</u>	<u>N</u>
Overall	2023	16%	21%	23%	8%	9%	713
Age	18 to 34	13%	17%	23%	14%	24%	168
	35 to 49	22%	15%	28%	3%	8%	149
	50 to 64	12%	32%	20%	5%	5%	201
	65 and older	18%	18%	21%	10%	3%	194
Children in Household	Children in household	20%	27%	24%	3%	5%	174
	No children in household	15%	19%	22%	10%	11%	539
Employment Status	Employed full-time	16%	23%	24%	8%	15%	366
	Employed part-time	16%	16%	33%	1%	8%	84
	Retired or not working	20%	17%	19%	11%	2%	225
	Unemployed	2%	51%	2%		11%	23
Gender	Men	13%	22%	25%	7%	16%	306
	Women	18%	22%	19%	8%	5%	375
Home Location	Open country or farm	18%	22%	22%	3%	10%	299
	In a suburban setting	13%	23%	28%	11%	5%	262
	In an urban setting	21%	17%	15%	14%	17%	142
Home Type	Detached single-family	17%	22%	23%	7%	7%	533
	Apartment/Duplex	17%	18%	18%	15%	23%	112
	Mobile home	11%	20%	3%	4%	34%	8
	Townhouse/Condominium	6%	24%	46%	6%		38
Household Income	Less than \$45,000	17%	21%	9%	15%	4%	104
	\$45,000 - \$74,999	18%	18%	14%	9%	16%	169
	\$75,000 - \$99,999	12%	26%	35%	9%	4%	102
	\$100,000 - \$149,999	14%	26%	23%	3%	7%	144
	\$150,000 or more	15%	20%	30%	4%	15%	107
Household Size	1 Person HH	7%	25%	27%	19%	2%	98
	2 People HH	18%	19%	20%	10%	14%	352
	3+ People HH	19%	24%	26%	2%	5%	247
Level of Education	High school or less	21%	20%	23%	5%	13%	207
	Tech school/Some college	14%	24%	17%	4%	14%	183
	College graduate	15%	17%	25%	17%	4%	188
	Postgraduate work	13%	24%	26%	4%	6%	134
Own or Rent Home	Own home	16%	22%	23%	7%	8%	553
	Rent home	14%	23%	23%	14%	17%	139
Region of State	Central Vermont	13%	22%	17%	6%	4%	127
	Chittenden County	21%	20%	30%	12%	4%	210
	Northern Counties	14%	14%	26%	12%	11%	148
	Southern Vermont	15%	27%	18%	3%	15%	221
Years Lived in VT	10 years or less	14%	20%	26%	7%	7%	133
	11-20 years	24%	24%	16%	11%	5%	103
	More than 20 years	15%	20%	23%	8%	11%	475

Q6: On average, how full was the container when it was emptied?

		<u>Completely or almost full</u>	<u>About 3/4 (75%) full</u>	<u>About half (50%) full</u>	<u>About 1/4 (25%) or less full</u>	<u>N</u>
Overall	2023	55%	28%	15%	2%	646
Age	18 to 34	65%	19%	12%	5%	128
	35 to 49	54%	33%	12%	1%	138
	50 to 64	51%	25%	21%	2%	191
	65 and older	52%	34%	12%	2%	189
Children in Household	Children in household	61%	30%	7%	2%	166
	No children in household	52%	28%	17%	3%	479
Employment Status	Employed full-time	58%	26%	14%	2%	311
	Employed part-time	55%	20%	19%	6%	78
	Retired or not working	46%	38%	15%	1%	221
	Unemployed	74%	9%	1%	16%	20
Gender	Men	48%	30%	21%	1%	258
	Women	60%	27%	10%	3%	359
Home Location	Open country or farm	53%	28%	17%	2%	268
	In a suburban setting	56%	29%	13%	2%	250
	In an urban setting	52%	31%	13%	4%	119
Home Type	Detached single-family	57%	27%	14%	2%	495
	Apartment/Duplex	52%	33%	15%		86
	Mobile home	59%	34%	0%	7%	5
	Townhouse/Condominium	27%	40%	25%	8%	37
Household Income	Less than \$45,000	59%	15%	17%	8%	100
	\$45,000 - \$74,999	57%	25%	17%	1%	142
	\$75,000 - \$99,999	33%	41%	24%	1%	98
	\$100,000 - \$149,999	57%	30%	12%	1%	134
	\$150,000 or more	77%	17%	5%	1%	91
Household Size	1 Person HH	53%	25%	16%	6%	96
	2 People HH	53%	29%	17%	1%	302
	3+ People HH	56%	30%	11%	2%	236
Level of Education	High school or less	40%	43%	17%		180
	Tech school/Some college	54%	18%	23%	5%	157
	College graduate	62%	26%	8%	3%	182
	Postgraduate work	66%	24%	9%	2%	126
Own or Rent Home	Own home	55%	28%	15%	2%	510
	Rent home	53%	34%	11%	2%	115
Region of State	Central Vermont	59%	18%	20%	3%	122
	Chittenden County	55%	30%	14%	1%	202
	Northern Counties	61%	27%	8%	4%	131
	Southern Vermont	46%	34%	16%	3%	188
Years Lived in VT	10 years or less	56%	26%	17%	0%	123
	11-20 years	73%	25%	2%	1%	97
	More than 20 years	50%	30%	17%	3%	423

Q7#: Thinking about all of the food waste set aside for composting by your household last week, please estimate approximately what percentage was dealt with in each of the following ways - Thrown in the regular trash

		0%	1-24%	25-49%	50-74%	75-99%	100%	Mean	N
Overall	2023	58%	32%	4%	3%	3%	0%	9%	485
Age	18 to 34	46%	32%	7%	10%	5%		14%	114
	35 to 49	42%	46%	5%	1%	6%		13%	101
	50 to 64	66%	31%	1%	1%	2%		5%	141
	65 and older	72%	24%	3%	1%	0%	0%	4%	128
Children in Household	Children in household	46%	31%	10%	1%	11%		16%	103
	No children in household	61%	33%	2%	4%	1%	0%	7%	381
Employment Status	Employed full-time	50%	36%	3%	6%	4%		11%	236
	Employed part-time	77%	15%	7%				3%	64
	Retired or not working	58%	35%	2%	1%	3%	0%	9%	162
	Unemployed	87%	13%					0%	9
Gender	Men	58%	34%	4%	2%	1%	0%	7%	180
	Women	58%	32%	3%	4%	3%	0%	9%	275
Home Location	Open country or farm	56%	33%	5%	4%	2%	1%	9%	207
	In a suburban setting	59%	32%	2%	3%	3%		8%	183
	In an urban setting	54%	34%	5%	1%	6%		13%	86
Home Type	Detached single-family	58%	32%	4%	3%	3%	0%	8%	371
	Apartment/Duplex	37%	45%	3%	6%	8%		19%	66
	Mobile home	36%	56%		8%			13%	4
	Townhouse/Condominium	88%	12%	0%				1%	27
Household Income	Less than \$45,000	57%	35%	1%		8%		11%	68
	\$45,000 - \$74,999	41%	48%	4%	7%	0%		12%	115
	\$75,000 - \$99,999	71%	20%	2%	7%	1%		7%	72
	\$100,000 - \$149,999	61%	30%	8%		1%		5%	104
	\$150,000 or more	58%	37%	3%	1%		0%	5%	70
Household Size	1 Person HH	57%	29%	3%	10%		1%	10%	78
	2 People HH	61%	31%	2%	3%	3%	0%	8%	226
	3+ People HH	52%	37%	6%	1%	4%		10%	172
Level of Education	High school or less	57%	43%					6%	98
	Tech school/Some college	66%	19%	4%		11%		13%	112
	College graduate	51%	35%	6%	8%	1%		10%	165
	Postgraduate work	60%	34%	4%	1%	1%	0%	5%	109
Own or Rent Home	Own home	61%	32%	4%	2%	1%	0%	6%	387
	Rent home	48%	38%	4%	9%			13%	80
Region of State	Central Vermont	48%	40%	5%		6%	1%	12%	97
	Chittenden County	59%	33%	5%	3%			7%	165
	Northern Counties	56%	32%		10%	2%		10%	94
	Southern Vermont	64%	26%	3%	1%	6%		8%	127
Years Lived in VT	10 years or less	54%	24%	6%	11%	5%	0%	15%	97
	11-20 years	55%	30%	8%		7%		10%	83
	More than 20 years	59%	36%	2%	2%	1%	0%	7%	305

Q8#: Thinking about all of the food waste set aside for composting by your household last week, please estimate approximately what percentage was dealt with in each of the following ways - Fed to farm animals or livestock

		0%	1-24%	25-49%	50-74%	75-99%	100%	Mean	N
Overall	2023	87%	5%	2%	3%	3%	1%	6%	485
Age	18 to 34	87%	7%			6%		6%	114
	35 to 49	89%	3%	3%	2%	3%	1%	6%	101
	50 to 64	78%	7%	2%	8%	3%	2%	10%	141
	65 and older	94%	2%	2%	2%	0%		2%	128
Children in Household	Children in household	85%	7%	1%	2%	3%	1%	6%	103
	No children in household	87%	4%	2%	3%	3%	1%	6%	381
Employment Status	Employed full-time	84%	7%	2%	1%	5%	1%	8%	236
	Employed part-time	94%	0%	1%	4%	1%		3%	64
	Retired or not working	87%	3%	2%	7%	1%	0%	5%	162
	Unemployed	89%			5%	6%		8%	9
Gender	Men	85%	4%	2%	7%	2%	0%	7%	180
	Women	87%	5%	1%	1%	4%	1%	6%	275
Home Location	Open country or farm	74%	9%	3%	7%	6%	0%	11%	207
	In a suburban setting	96%	2%	0%	0%	0%	1%	2%	183
	In an urban setting	96%		1%	0%	3%		3%	86
Home Type	Detached single-family	85%	5%	1%	4%	4%	1%	7%	371
	Apartment/Duplex	90%	6%	4%				3%	66
	Mobile home	99%			1%			0%	4
	Townhouse/Condominium	98%		2%				1%	27
Household Income	Less than \$45,000	88%	4%	2%	2%	1%	4%	7%	68
	\$45,000 - \$74,999	77%	8%	1%	9%	5%		10%	115
	\$75,000 - \$99,999	93%	2%	0%	1%	3%		4%	72
	\$100,000 - \$149,999	87%	3%	5%	0%	5%		7%	104
	\$150,000 or more	89%	5%	1%	3%	2%	1%	5%	70
Household Size	1 Person HH	90%	7%	1%	2%	0%		3%	78
	2 People HH	85%	3%	3%	5%	3%	1%	8%	226
	3+ People HH	87%	6%	1%	1%	5%	0%	6%	172
Level of Education	High school or less	90%			10%			5%	98
	Tech school/Some college	82%	7%	4%	1%	4%	2%	9%	112
	College graduate	90%	6%	1%	1%	2%	0%	4%	165
	Postgraduate work	84%	5%	2%	2%	6%		7%	109
Own or Rent Home	Own home	85%	5%	2%	4%	4%	1%	7%	387
	Rent home	94%	5%	1%	1%			2%	80
Region of State	Central Vermont	80%	3%	3%	11%	3%		10%	97
	Chittenden County	94%	4%		0%	1%	0%	2%	165
	Northern Counties	82%	9%		2%	5%	3%	9%	94
	Southern Vermont	87%	4%	4%	2%	4%		6%	127
Years Lived in VT	10 years or less	85%	10%	2%	2%	1%		4%	97
	11-20 years	96%	2%	1%	1%	0%		1%	83
	More than 20 years	85%	4%	2%	4%	5%	1%	8%	305

Q9#: Thinking about all of the food waste set aside for composting by your household last week, please estimate approximately what percentage was dealt with in each of the following ways - Fed to pets

		0%	1-24%	25-49%	50-74%	75-99%	Mean	N
Overall	2023	85%	11%	3%	0%	0%	2%	485
Age	18 to 34	87%	10%	3%			1%	114
	35 to 49	76%	22%	2%	1%		2%	101
	50 to 64	90%	10%		0%	0%	1%	141
	65 and older	86%	5%	9%	0%		3%	128
Children in Household	Children in household	77%	22%	1%	0%		2%	103
	No children in household	88%	8%	4%	0%	0%	2%	381
Employment Status	Employed full-time	83%	14%	2%	0%	0%	2%	236
	Employed part-time	90%	7%	2%		1%	2%	64
	Retired or not working	85%	8%	6%	0%		3%	162
	Unemployed	97%	3%				0%	9
Gender	Men	86%	10%	3%	0%		2%	180
	Women	83%	13%	4%	0%	0%	2%	275
Home Location	Open country or farm	80%	16%	3%	1%	0%	2%	207
	In a suburban setting	93%	5%	1%		0%	1%	183
	In an urban setting	88%	11%	0%			1%	86
Home Type	Detached single-family	84%	11%	4%	0%	0%	2%	371
	Apartment/Duplex	87%	13%				1%	66
	Mobile home	68%	31%	1%			5%	4
	Townhouse/Condominium	100%					0%	27
Household Income	Less than \$45,000	69%	16%	14%			5%	68
	\$45,000 - \$74,999	91%	5%	5%			2%	115
	\$75,000 - \$99,999	89%	11%	0%			1%	72
	\$100,000 - \$149,999	85%	13%		1%	1%	2%	104
	\$150,000 or more	82%	17%	0%			1%	70
Household Size	1 Person HH	75%	7%	17%		0%	6%	78
	2 People HH	88%	11%	1%		0%	1%	226
	3+ People HH	86%	13%	0%	1%		1%	172
Level of Education	High school or less	89%	2%	9%			3%	98
	Tech school/Some college	82%	16%	2%			1%	112
	College graduate	86%	10%	3%	1%		2%	165
	Postgraduate work	84%	14%	1%	0%	1%	2%	109
Own or Rent Home	Own home	85%	12%	3%	0%	0%	2%	387
	Rent home	92%	3%	6%			2%	80
Region of State	Central Vermont	83%	14%	2%	1%		2%	97
	Chittenden County	95%	5%	0%		0%	0%	165
	Northern Counties	69%	17%	15%			6%	94
	Southern Vermont	87%	12%	1%	0%	0%	1%	127
Years Lived in VT	10 years or less	80%	19%		1%		1%	97
	11-20 years	92%	7%	0%			0%	83
	More than 20 years	85%	9%	5%	0%	0%	2%	305

Q10#: Thinking about all of the food waste set aside for composting by your household last week, please estimate approximately what percentage was dealt with in each of the following ways - Placed in your own compost pile or composter

		<u>0%</u>	<u>1-24%</u>	<u>25-49%</u>	<u>50-74%</u>	<u>75-99%</u>	<u>100%</u>	<u>Mean</u>	<u>N</u>
Overall	2023	35%	5%	5%	7%	25%	23%	53%	485
Age	18 to 34	38%	7%	7%	5%	22%	21%	49%	114
	35 to 49	45%	8%	1%	9%	26%	12%	41%	101
	50 to 64	27%	4%	8%	3%	28%	30%	61%	141
	65 and older	33%	2%	2%	12%	25%	27%	57%	128
Children in Household	Children in household	26%	13%	1%	10%	34%	15%	54%	103
	No children in household	37%	2%	6%	6%	23%	25%	53%	381
Employment Status	Employed full-time	28%	8%	4%	5%	33%	22%	57%	236
	Employed part-time	44%	3%	3%	13%	10%	27%	46%	64
	Retired or not working	44%	1%	7%	8%	22%	18%	46%	162
	Unemployed	2%	17%	2%	5%	13%	61%	78%	9
Gender	Men	30%	4%	7%	6%	27%	26%	57%	180
	Women	39%	4%	4%	9%	25%	20%	50%	275
Home Location	Open country or farm	18%	6%	10%	8%	33%	26%	64%	207
	In a suburban setting	46%	5%	1%	4%	23%	22%	46%	183
	In an urban setting	56%	3%	1%	3%	14%	23%	38%	86
Home Type	Detached single-family	23%	6%	6%	8%	31%	26%	62%	371
	Apartment/Duplex	80%		1%	4%	8%	6%	17%	66
	Mobile home	31%	1%		31%	25%	12%	55%	4
	Townhouse/Condominium	96%		2%		1%	1%	2%	27
Household Income	Less than \$45,000	32%	1%	2%	19%	29%	18%	57%	68
	\$45,000 - \$74,999	37%	3%	11%	5%	25%	18%	49%	115
	\$75,000 - \$99,999	45%	1%	8%	1%	16%	28%	46%	72
	\$100,000 - \$149,999	28%	7%	1%	11%	24%	28%	58%	104
	\$150,000 or more	25%	5%	1%	5%	44%	20%	63%	70
Household Size	1 Person HH	54%	0%	3%	13%	18%	13%	39%	78
	2 People HH	30%	3%	9%	5%	27%	27%	58%	226
	3+ People HH	34%	10%	1%	8%	28%	19%	51%	172
Level of Education	High school or less	50%		10%	9%	14%	18%	40%	98
	Tech school/Some college	24%	9%	1%	9%	22%	36%	62%	112
	College graduate	38%	2%	4%	6%	33%	17%	52%	165
	Postgraduate work	27%	9%	5%	6%	28%	25%	56%	109
Own or Rent Home	Own home	26%	4%	6%	8%	29%	26%	60%	387
	Rent home	77%	1%	1%	3%	9%	9%	20%	80
Region of State	Central Vermont	23%	1%	12%	8%	27%	30%	64%	97
	Chittenden County	59%	3%	0%	4%	18%	15%	34%	165
	Northern Counties	20%	5%	10%	12%	42%	12%	62%	94
	Southern Vermont	24%	9%	1%	8%	22%	35%	62%	127
Years Lived in VT	10 years or less	43%	3%	7%	5%	26%	15%	45%	97
	11-20 years	29%	9%	0%	11%	28%	22%	57%	83
	More than 20 years	34%	4%	5%	7%	24%	26%	54%	305

Q11#: Thinking about all of the food waste set aside for composting by your household last week, please estimate approximately what percentage was dealt with in each of the following ways - Picked up by a waste hauler specifically for composting

		0%	1-24%	25-49%	50-74%	75-99%	100%	Mean	N
Overall	2023	82%	0%	0%	1%	7%	10%	16%	485
Age	18 to 34	83%			2%	5%	10%	16%	114
	35 to 49	70%	0%		1%	23%	6%	26%	101
	50 to 64	89%	1%	0%		2%	8%	10%	141
	65 and older	82%	0%	0%	0%	2%	15%	17%	128
Children in Household	Children in household	87%		1%	1%	5%	7%	12%	103
	No children in household	81%	0%	0%	1%	8%	10%	17%	381
Employment Status	Employed full-time	87%	0%	0%	1%	3%	8%	12%	236
	Employed part-time	87%			0%	9%	4%	12%	64
	Retired or not working	72%	0%	0%	0%	12%	15%	25%	162
	Unemployed	85%				13%	2%	14%	9
Gender	Men	87%	1%	0%	0%	4%	8%	11%	180
	Women	78%	0%	0%	0%	10%	12%	20%	275
Home Location	Open country or farm	93%	0%		0%	2%	4%	6%	207
	In a suburban setting	77%	0%	0%	0%	7%	15%	22%	183
	In an urban setting	64%	1%	0%	3%	19%	13%	30%	86
Home Type	Detached single-family	92%	0%	0%	0%	2%	5%	7%	371
	Apartment/Duplex	57%			3%	30%	9%	36%	66
	Mobile home	100%						0%	4
	Townhouse/Condominium	9%		2%	0%	11%	78%	89%	27
Household Income	Less than \$45,000	89%				7%	4%	10%	68
	\$45,000 - \$74,999	80%	0%	0%	2%	16%	2%	16%	115
	\$75,000 - \$99,999	82%				4%	14%	18%	72
	\$100,000 - \$149,999	79%	0%	1%	1%	5%	14%	19%	104
	\$150,000 or more	80%	1%			2%	17%	19%	70
Household Size	1 Person HH	75%			3%	8%	14%	23%	78
	2 People HH	86%	1%	0%	0%	3%	10%	13%	226
	3+ People HH	79%		0%	0%	12%	8%	19%	172
Level of Education	High school or less	68%				19%	13%	28%	98
	Tech school/Some college	92%				2%	6%	8%	112
	College graduate	84%	1%		2%	2%	12%	15%	165
	Postgraduate work	81%	1%	1%	0%	10%	8%	17%	109
Own or Rent Home	Own home	86%	0%	0%	0%	4%	9%	13%	387
	Rent home	57%		1%	3%	25%	14%	37%	80
Region of State	Central Vermont	95%		1%		0%	5%	5%	97
	Chittenden County	61%	0%	0%	2%	15%	22%	36%	165
	Northern Counties	96%	0%			2%	2%	4%	94
	Southern Vermont	90%	0%		0%	6%	3%	9%	127
Years Lived in VT	10 years or less	75%		1%	2%	7%	15%	23%	97
	11-20 years	84%				4%	13%	16%	83
	More than 20 years	83%	1%	0%	0%	8%	7%	14%	305

Q12#: Thinking about all of the food waste set aside for composting by your household last week, please estimate approximately what percentage was dealt with in each of the following ways - Dropped off at a transfer station or other collection point specifically for composting

		0%	1-24%	25-49%	50-74%	75-99%	100%	Mean	N
Overall	2023	81%	4%	1%	1%	2%	11%	14%	485
Age	18 to 34	84%	3%			3%	10%	13%	114
	35 to 49	82%	4%	1%	1%	3%	8%	12%	101
	50 to 64	80%	5%	2%		1%	12%	14%	141
	65 and older	79%	2%	1%	3%	3%	12%	16%	128
Children in Household	Children in household	85%	5%		1%	3%	7%	10%	103
	No children in household	81%	4%	1%	1%	2%	11%	15%	381
Employment Status	Employed full-time	84%	5%	1%	0%	4%	6%	10%	236
	Employed part-time	55%	7%	3%	4%	1%	30%	34%	64
	Retired or not working	85%	2%	1%	1%	1%	11%	12%	162
	Unemployed	100%						0%	9
Gender	Men	80%	3%	1%	1%	3%	14%	17%	180
	Women	82%	5%	1%	1%	3%	9%	13%	275
Home Location	Open country or farm	87%	5%	1%	1%	2%	5%	7%	207
	In a suburban setting	73%	5%	1%	2%	4%	16%	21%	183
	In an urban setting	84%	0%	0%	0%	0%	15%	15%	86
Home Type	Detached single-family	82%	4%	1%	1%	2%	10%	13%	371
	Apartment/Duplex	71%	6%			6%	17%	24%	66
	Mobile home	69%			8%		23%	27%	4
	Townhouse/Condominium	93%					7%	7%	27
Household Income	Less than \$45,000	88%	0%		4%	1%	8%	10%	68
	\$45,000 - \$74,999	82%	5%	1%	0%	3%	8%	12%	115
	\$75,000 - \$99,999	73%	1%	1%	1%	1%	23%	24%	72
	\$100,000 - \$149,999	83%	8%	1%	0%	4%	5%	9%	104
	\$150,000 or more	88%	4%	0%	1%	1%	5%	7%	70
Household Size	1 Person HH	75%	5%	1%	0%	5%	12%	19%	78
	2 People HH	83%	3%	1%	1%	2%	11%	13%	226
	3+ People HH	82%	5%	0%	1%	2%	10%	13%	172
Level of Education	High school or less	82%					18%	18%	98
	Tech school/Some college	88%	3%		2%	1%	5%	7%	112
	College graduate	76%	7%	1%	1%	4%	12%	17%	165
	Postgraduate work	82%	3%	2%	1%	3%	8%	13%	109
Own or Rent Home	Own home	84%	4%	1%	1%	2%	9%	12%	387
	Rent home	66%	5%	1%	3%	5%	20%	27%	80
Region of State	Central Vermont	88%	4%	0%	1%	1%	6%	8%	97
	Chittenden County	75%	5%	0%	0%	4%	15%	20%	165
	Northern Counties	84%	4%	1%	2%	1%	8%	11%	94
	Southern Vermont	83%	2%	2%	1%	2%	11%	14%	127
Years Lived in VT	10 years or less	80%	5%	2%	3%	1%	9%	13%	97
	11-20 years	79%	5%		0%	2%	13%	15%	83
	More than 20 years	82%	3%	1%	1%	3%	10%	14%	305

Q13: Which method(s) do you use for composting? (Select all that apply)

		<u>I do not have my own composting method at home, my food scraps are dropped off or hauled</u>	<u>I put the scraps in a stationary bin outside that I built</u>	<u>I put the scraps in a stationary bin outside that I purchased</u>
Overall	2023	21%	14%	18%
Age	18 to 34	21%	22%	20%
	35 to 49	31%	12%	12%
	50 to 64	13%	11%	21%
	65 and older	23%	13%	18%
Children in Household	Children in household	16%	13%	14%
	No children in household	23%	15%	19%
Employment Status	Employed full-time	16%	19%	16%
	Employed part-time	16%	12%	29%
	Retired or not working	32%	9%	14%
	Unemployed	15%	3%	54%
Gender	Men	16%	19%	17%
	Women	24%	11%	18%
Home Location	Open country or farm	7%	20%	15%
	In a suburban setting	26%	7%	23%
	In an urban setting	43%	18%	17%
Home Type	Detached single-family	11%	15%	20%
	Apartment/Duplex	47%	19%	14%
	Mobile home	39%	4%	20%
	Townhouse/Condominium	82%	2%	10%
Household Income	Less than \$45,000	23%	5%	17%
	\$45,000 - \$74,999	26%	26%	16%
	\$75,000 - \$99,999	19%	11%	21%
	\$100,000 - \$149,999	22%	12%	22%
	\$150,000 or more	7%	15%	18%
Household Size	1 Person HH	33%	9%	20%
	2 People HH	21%	17%	18%
	3+ People HH	17%	13%	19%
Level of Education	High school or less	22%	15%	9%
	Tech school/Some college	14%	12%	22%
	College graduate	28%	15%	18%
	Postgraduate work	20%	16%	27%
Own or Rent Home	Own home	14%	14%	19%
	Rent home	46%	17%	18%
Region of State	Central Vermont	17%	16%	23%
	Chittenden County	42%	7%	17%
	Northern Counties	15%	19%	10%
	Southern Vermont	8%	17%	22%
Years Lived in VT	10 years or less	32%	23%	20%
	11-20 years	23%	18%	14%
	More than 20 years	18%	11%	18%

Q13: Which method(s) do you use for composting? (Select all that apply)

		<u>I put the scraps in a unit outside that turns or rotates</u>	<u>I put the scraps outside in a pile or heap</u>	<u>Some other method</u>	<u>N</u>
Overall	2023	13%	32%	17%	710
Age	18 to 34	8%	32%	19%	168
	35 to 49	12%	28%	17%	149
	50 to 64	10%	42%	10%	200
	65 and older	20%	24%	22%	194
Children in Household	Children in household	12%	37%	20%	174
	No children in household	13%	30%	16%	536
Employment Status	Employed full-time	12%	37%	17%	363
	Employed part-time	14%	28%	14%	84
	Retired or not working	16%	24%	20%	225
	Unemployed	1%	15%	16%	23
Gender	Men	13%	30%	22%	306
	Women	13%	33%	14%	374
Home Location	Open country or farm	15%	39%	17%	296
	In a suburban setting	12%	25%	16%	262
	In an urban setting	4%	24%	13%	143
Home Type	Detached single-family	16%	34%	19%	530
	Apartment/Duplex	5%	28%	6%	112
	Mobile home	3%	21%	12%	8
	Townhouse/Condominium	0%	3%	16%	38
Household Income	Less than \$45,000	20%	37%	21%	104
	\$45,000 - \$74,999	9%	38%	5%	169
	\$75,000 - \$99,999	7%	40%	14%	101
	\$100,000 - \$149,999	18%	25%	17%	144
	\$150,000 or more	15%	12%	40%	107
Household Size	1 Person HH	16%	15%	25%	98
	2 People HH	13%	32%	14%	349
	3+ People HH	12%	34%	19%	247
Level of Education	High school or less	14%	44%	19%	207
	Tech school/Some college	7%	33%	18%	180
	College graduate	13%	24%	15%	189
	Postgraduate work	17%	22%	15%	134
Own or Rent Home	Own home	16%	33%	19%	550
	Rent home	2%	27%	9%	139
Region of State	Central Vermont	13%	32%	11%	127
	Chittenden County	11%	15%	15%	211
	Northern Counties	18%	28%	33%	147
	Southern Vermont	11%	49%	11%	218
Years Lived in VT	10 years or less	11%	22%	6%	133
	11-20 years	9%	39%	8%	103
	More than 20 years	14%	33%	22%	472

Q14_1#: About what percentage of food scraps do you typically compost at each of the following times of the year? Winter (recoded)

		<u>0%</u>	<u>1-24%</u>	<u>25-49%</u>	<u>50-74%</u>	<u>75-99%</u>	<u>100%</u>	<u>Mean</u>	<u>N</u>
Overall	2023	15%	7%	6%	5%	30%	37%	69%	714
Age	18 to 34	30%	1%	9%	5%	25%	30%	58%	168
	35 to 49	20%	4%	5%	9%	40%	21%	62%	149
	50 to 64	7%	9%	4%	3%	31%	46%	78%	202
	65 and older	6%	11%	8%	5%	24%	45%	73%	194
Children in Household	Children in household	20%	6%	5%	9%	35%	26%	64%	174
	No children in household	13%	7%	7%	4%	28%	40%	70%	539
Employment Status	Employed full-time	23%	3%	6%	7%	30%	30%	63%	366
	Employed part-time	6%	3%	6%	5%	17%	63%	83%	84
	Retired or not working	8%	16%	5%	2%	28%	41%	71%	226
	Unemployed			23%	10%	53%	13%	68%	23
Gender	Men	20%	9%	7%	6%	24%	35%	62%	306
	Women	10%	6%	6%	5%	35%	39%	75%	376
Home Location	Open country or farm	17%	10%	9%	5%	26%	33%	63%	299
	In a suburban setting	9%	4%	5%	8%	35%	40%	78%	263
	In an urban setting	23%	6%	5%	1%	28%	37%	63%	143
Home Type	Detached single-family	14%	8%	7%	5%	29%	37%	69%	534
	Apartment/Duplex	24%	4%	5%	4%	32%	31%	62%	112
	Mobile home	8%	3%	10%	4%	62%	13%	71%	8
	Townhouse/Condominium	4%	0%	1%	15%	9%	71%	88%	38
Household Income	Less than \$45,000	7%	12%	5%	1%	39%	35%	71%	104
	\$45,000 - \$74,999	18%	13%	6%	6%	34%	23%	61%	169
	\$75,000 - \$99,999	11%	1%	5%	4%	31%	48%	80%	102
	\$100,000 - \$149,999	7%	5%	9%	13%	20%	45%	74%	144
	\$150,000 or more	16%	5%	2%	3%	40%	35%	71%	107
Household Size	1 Person HH	2%	2%	12%	8%	29%	47%	81%	98
	2 People HH	20%	8%	7%	4%	24%	37%	63%	352
	3+ People HH	11%	7%	4%	7%	36%	35%	73%	248
Level of Education	High school or less	15%	14%	4%	2%	40%	25%	64%	207
	Tech school/Some college	23%	5%	7%	6%	21%	39%	63%	183
	College graduate	12%	3%	8%	8%	25%	44%	75%	189
	Postgraduate work	8%	5%	8%	5%	32%	42%	76%	134
Own or Rent Home	Own home	13%	8%	6%	5%	31%	38%	70%	554
	Rent home	17%	3%	7%	8%	28%	37%	68%	139
Region of State	Central Vermont	10%	16%	6%	4%	23%	40%	67%	127
	Chittenden County	8%	2%	5%	8%	25%	53%	82%	211
	Northern Counties	16%	8%	6%	2%	41%	27%	66%	148
	Southern Vermont	22%	5%	8%	6%	31%	28%	61%	221
Years Lived in VT	10 years or less	11%	10%	9%	12%	25%	33%	66%	133
	11-20 years	22%	3%	6%	7%	24%	39%	67%	102
	More than 20 years	15%	7%	6%	3%	32%	37%	70%	476

Q14_2#: About what percentage of food scraps do you typically compost at each of the following times of the year? Spring (recoded)

		<u>0%</u>	<u>1-24%</u>	<u>25-49%</u>	<u>50-74%</u>	<u>75-99%</u>	<u>100%</u>	<u>Mean</u>	<u>N</u>
Overall	2023	8%	6%	11%	3%	33%	39%	73%	714
Age	18 to 34	10%	15%	12%	1%	32%	30%	65%	168
	35 to 49	16%	5%	5%	8%	43%	22%	66%	149
	50 to 64	6%	3%	6%	1%	36%	49%	83%	202
	65 and older	4%	4%	19%	2%	23%	49%	77%	194
Children in Household	Children in household	13%	5%	8%	7%	40%	27%	69%	174
	No children in household	7%	7%	12%	2%	30%	43%	75%	539
Employment Status	Employed full-time	12%	10%	10%	4%	32%	33%	67%	366
	Employed part-time	4%	2%	7%	1%	18%	68%	87%	84
	Retired or not working	6%	3%	13%	1%	34%	42%	77%	226
	Unemployed			23%	9%	54%	13%	76%	23
Gender	Men	12%	10%	11%	3%	26%	38%	67%	306
	Women	6%	3%	8%	3%	40%	40%	79%	376
Home Location	Open country or farm	13%	5%	11%	4%	32%	35%	69%	299
	In a suburban setting	5%	4%	10%	3%	37%	42%	80%	263
	In an urban setting	6%	15%	11%	1%	30%	37%	69%	143
Home Type	Detached single-family	9%	3%	11%	4%	33%	40%	75%	534
	Apartment/Duplex	6%	24%	6%	0%	32%	32%	65%	112
	Mobile home	8%	0%	10%	4%	65%	13%	73%	8
	Townhouse/Condominium	4%	0%	15%		10%	71%	84%	38
Household Income	Less than \$45,000	7%	3%	14%	1%	40%	35%	77%	104
	\$45,000 - \$74,999	2%	17%	12%	3%	43%	24%	69%	169
	\$75,000 - \$99,999	5%	1%	4%	2%	37%	50%	86%	102
	\$100,000 - \$149,999	5%	5%	13%	6%	21%	50%	77%	144
	\$150,000 or more	14%	3%	2%	5%	40%	35%	73%	107
Household Size	1 Person HH	2%	5%	11%	2%	30%	50%	84%	98
	2 People HH	11%	8%	14%	1%	28%	39%	69%	352
	3+ People HH	5%	6%	7%	6%	40%	36%	77%	248
Level of Education	High school or less	4%	13%	14%		43%	26%	69%	207
	Tech school/Some college	19%	3%	11%	4%	21%	42%	67%	183
	College graduate	6%	5%	8%	4%	31%	46%	79%	189
	Postgraduate work	5%	3%	9%	4%	35%	44%	80%	134
Own or Rent Home	Own home	9%	3%	9%	3%	35%	40%	76%	554
	Rent home	2%	19%	11%	2%	28%	38%	69%	139
Region of State	Central Vermont	8%	4%	13%	4%	31%	40%	74%	127
	Chittenden County	6%	3%	9%	2%	26%	55%	81%	211
	Northern Counties	12%	1%	12%	1%	45%	28%	72%	148
	Southern Vermont	7%	15%	10%	5%	33%	31%	68%	221
Years Lived in VT	10 years or less	6%	4%	16%	5%	33%	35%	73%	133
	11-20 years	15%	1%	11%	4%	28%	40%	71%	102
	More than 20 years	8%	8%	9%	2%	34%	39%	74%	476

Q14_3#: About what percentage of food scraps do you typically compost at each of the following times of the year? Summer (recoded)

		<u>0%</u>	<u>1-24%</u>	<u>25-49%</u>	<u>50-74%</u>	<u>75-99%</u>	<u>100%</u>	<u>Mean</u>	<u>N</u>
Overall	2023	9%	7%	8%	4%	33%	39%	74%	714
Age	18 to 34	10%	15%	8%	5%	31%	31%	65%	168
	35 to 49	16%	7%	4%	6%	45%	22%	66%	149
	50 to 64	6%	2%	6%	1%	36%	49%	84%	202
	65 and older	5%	6%	12%	6%	23%	49%	78%	194
Children in Household	Children in household	13%	6%	4%	9%	41%	27%	70%	174
	No children in household	7%	7%	9%	3%	31%	43%	76%	539
Employment Status	Employed full-time	12%	11%	7%	4%	35%	32%	68%	366
	Employed part-time	4%	2%	7%	1%	17%	69%	87%	84
	Retired or not working	7%	4%	9%	4%	36%	41%	78%	226
	Unemployed			23%	9%	13%	55%	79%	23
Gender	Men	12%	12%	7%	6%	26%	38%	68%	306
	Women	6%	3%	8%	2%	40%	41%	80%	376
Home Location	Open country or farm	13%	4%	11%	3%	33%	36%	70%	299
	In a suburban setting	5%	6%	6%	4%	40%	39%	80%	263
	In an urban setting	6%	15%	5%	7%	24%	43%	71%	143
Home Type	Detached single-family	9%	3%	9%	5%	34%	40%	76%	534
	Apartment/Duplex	6%	26%	5%	0%	30%	33%	64%	112
	Mobile home	8%	0%	7%	4%	68%	13%	75%	8
	Townhouse/Condominium	4%	14%	1%		10%	71%	83%	38
Household Income	Less than \$45,000	8%	4%	6%	7%	32%	44%	78%	104
	\$45,000 - \$74,999	2%	17%	11%	3%	45%	22%	69%	169
	\$75,000 - \$99,999	5%	1%	5%	2%	37%	51%	86%	102
	\$100,000 - \$149,999	5%	8%	10%	4%	23%	51%	78%	144
	\$150,000 or more	14%	3%	3%	4%	41%	35%	74%	107
Household Size	1 Person HH	2%	5%	11%	1%	28%	53%	84%	98
	2 People HH	11%	9%	10%	3%	28%	39%	70%	352
	3+ People HH	5%	6%	4%	7%	41%	36%	78%	248
Level of Education	High school or less	4%	15%	8%	3%	43%	26%	70%	207
	Tech school/Some college	20%	4%	6%	7%	16%	47%	68%	183
	College graduate	6%	5%	9%	2%	36%	42%	79%	189
	Postgraduate work	5%	2%	9%	4%	36%	44%	82%	134
Own or Rent Home	Own home	10%	3%	8%	4%	36%	40%	77%	554
	Rent home	2%	24%	6%	1%	27%	40%	68%	139
Region of State	Central Vermont	9%	3%	12%	3%	36%	36%	74%	127
	Chittenden County	6%	5%	7%	1%	28%	53%	81%	211
	Northern Counties	12%	1%	8%	6%	46%	28%	74%	148
	Southern Vermont	7%	15%	6%	6%	29%	36%	70%	221
Years Lived in VT	10 years or less	6%	6%	15%	5%	25%	43%	74%	133
	11-20 years	15%	0%	5%	9%	29%	40%	73%	102
	More than 20 years	8%	9%	6%	3%	36%	38%	74%	476

Q14_4#: About what percentage of food scraps do you typically compost at each of the following times of the year? Fall (recoded)

		0%	1-24%	25-49%	50-74%	75-99%	100%	Mean	N
Overall	2023	9%	6%	11%	4%	31%	39%	73%	714
Age	18 to 34	10%	13%	14%	3%	30%	30%	66%	168
	35 to 49	16%	4%	7%	7%	44%	22%	66%	149
	50 to 64	6%	3%	6%	5%	31%	49%	82%	202
	65 and older	5%	5%	17%	2%	23%	48%	75%	194
Children in Household	Children in household	13%	2%	12%	8%	39%	26%	69%	174
	No children in household	7%	7%	11%	3%	29%	43%	74%	539
Employment Status	Employed full-time	12%	8%	12%	3%	33%	32%	68%	366
	Employed part-time	4%	2%	6%	6%	13%	68%	86%	84
	Retired or not working	7%	5%	12%	5%	29%	42%	75%	226
	Unemployed			23%	9%	54%	13%	72%	23
Gender	Men	12%	11%	10%	6%	23%	37%	66%	306
	Women	6%	2%	10%	3%	39%	40%	79%	376
Home Location	Open country or farm	13%	3%	13%	8%	28%	35%	69%	299
	In a suburban setting	5%	3%	12%	2%	37%	41%	80%	263
	In an urban setting	6%	20%	6%	1%	30%	37%	68%	143
Home Type	Detached single-family	9%	4%	11%	5%	31%	39%	74%	534
	Apartment/Duplex	6%	21%	10%	0%	32%	32%	66%	112
	Mobile home	8%	0%	7%	4%	68%	13%	75%	8
	Townhouse/Condominium	4%	0%	15%		10%	71%	84%	38
Household Income	Less than \$45,000	8%	10%	8%		41%	34%	73%	104
	\$45,000 - \$74,999	2%	15%	14%	8%	37%	24%	69%	169
	\$75,000 - \$99,999	5%	1%	5%	2%	38%	50%	85%	102
	\$100,000 - \$149,999	5%	3%	15%	7%	20%	50%	78%	144
	\$150,000 or more	14%	3%	4%	3%	41%	35%	74%	107
Household Size	1 Person HH	2%	1%	15%	2%	30%	50%	83%	98
	2 People HH	11%	10%	11%	3%	25%	39%	68%	352
	3+ People HH	5%	4%	10%	7%	39%	35%	77%	248
Level of Education	High school or less	4%	14%	12%	5%	39%	26%	69%	207
	Tech school/Some college	20%	3%	11%	4%	21%	41%	66%	183
	College graduate	6%	2%	12%	5%	30%	45%	79%	189
	Postgraduate work	5%	4%	9%	3%	35%	44%	80%	134
Own or Rent Home	Own home	10%	4%	9%	5%	33%	40%	75%	554
	Rent home	2%	16%	14%	1%	28%	38%	70%	139
Region of State	Central Vermont	9%	2%	14%	11%	24%	40%	72%	127
	Chittenden County	6%	2%	10%	3%	25%	54%	82%	211
	Northern Counties	12%	6%	8%	1%	45%	28%	71%	148
	Southern Vermont	7%	13%	11%	4%	33%	31%	69%	221
Years Lived in VT	10 years or less	6%	2%	19%	5%	32%	36%	73%	133
	11-20 years	15%	1%	11%	7%	26%	40%	71%	102
	More than 20 years	8%	8%	9%	3%	33%	39%	73%	476

OWNRENT: Do you own or rent your home?

		<u>Own home</u>	<u>Rent home</u>	<u>Not applicable</u>	<u>N</u>
Overall	2023	73%	21%	6%	953
Age	18 to 34	42%	46%	12%	242
	35 to 49	67%	23%	11%	213
	50 to 64	90%	9%	1%	249
	65 and older	91%	8%	1%	248
Children in Household	Children in household	78%	14%	8%	253
	No children in household	71%	24%	5%	698
Employment Status	Employed full-time	72%	22%	6%	492
	Employed part-time	81%	19%	0%	101
	Retired or not working	75%	17%	8%	297
	Unemployed	44%	47%	9%	48
Gender	Men	78%	14%	8%	442
	Women	70%	27%	3%	474
Home Location	Open country or farm	88%	6%	6%	409
	In a suburban setting	71%	22%	7%	367
	In an urban setting	40%	55%	5%	168
Home Type	Detached single-family	92%	4%	4%	666
	Apartment/Duplex	8%	78%	14%	192
	Mobile home	99%	1%		19
	Townhouse/Condominium	63%	36%	0%	46
Household Income	Less than \$45,000	47%	40%	13%	190
	\$45,000 - \$74,999	62%	38%	0%	217
	\$75,000 - \$99,999	89%	9%	1%	124
	\$100,000 - \$149,999	92%	6%	2%	163
	\$150,000 or more	90%	2%	8%	140
Household Size	1 Person HH	46%	50%	4%	144
	2 People HH	80%	15%	5%	437
	3+ People HH	75%	17%	8%	355
Level of Education	High school or less	68%	21%	11%	299
	Tech school/Some college	73%	20%	7%	259
	College graduate	72%	27%	1%	231
	Postgraduate work	83%	15%	2%	163
Region of State	Central Vermont	84%	13%	3%	190
	Chittenden County	67%	26%	7%	257
	Northern Counties	73%	18%	9%	214
	Southern Vermont	69%	26%	5%	285
Years Lived in VT	10 years or less	65%	26%	8%	166
	11-20 years	81%	14%	5%	140
	More than 20 years	73%	21%	6%	645

Q15: Which best describes the location of your residence?

		<u>In a suburban setting</u>	<u>In an urban setting</u>	<u>On a farm</u>	<u>Open country, but not a farm</u>	<u>N</u>
Overall	2023	39%	18%	4%	40%	944
Age	18 to 34	37%	27%	3%	34%	242
	35 to 49	39%	21%	5%	35%	213
	50 to 64	43%	9%	4%	44%	249
	65 and older	37%	15%	3%	45%	239
Children in Household	Children in household	47%	11%	3%	39%	253
	No children in household	36%	20%	4%	40%	689
Employment Status	Employed full-time	40%	14%	4%	43%	492
	Employed part-time	40%	14%	5%	41%	101
	Retired or not working	38%	23%	2%	37%	288
	Unemployed	22%	41%	7%	30%	48
Gender	Men	36%	16%	2%	46%	441
	Women	42%	18%	5%	35%	465
Home Type	Detached single-family	35%	9%	4%	53%	657
	Apartment/Duplex	40%	45%	3%	11%	192
	Mobile home	61%	13%		26%	19
	Townhouse/Condominium	64%	31%		5%	46
Household Income	Less than \$45,000	45%	26%	4%	25%	181
	\$45,000 - \$74,999	25%	29%	7%	39%	217
	\$75,000 - \$99,999	50%	15%	2%	33%	124
	\$100,000 - \$149,999	37%	12%	4%	48%	162
	\$150,000 or more	40%	5%	3%	53%	140
Household Size	1 Person HH	41%	23%	5%	31%	135
	2 People HH	32%	21%	4%	44%	436
	3+ People HH	46%	13%	3%	38%	355
Level of Education	High school or less	43%	22%		36%	291
	Tech school/Some college	34%	19%	7%	40%	259
	College graduate	44%	13%	4%	40%	231
	Postgraduate work	33%	16%	3%	47%	162
Own or Rent Home	Own home	38%	10%	4%	49%	684
	Rent home	41%	46%	3%	10%	201
Region of State	Central Vermont	22%	18%	5%	56%	190
	Chittenden County	54%	24%	2%	20%	257
	Northern Counties	37%	7%	3%	53%	205
	Southern Vermont	39%	20%	5%	36%	285
Years Lived in VT	10 years or less	35%	22%	4%	39%	165
	11-20 years	33%	10%	1%	56%	140
	More than 20 years	41%	18%	4%	36%	636

Q16: Which of the following comes closest to the kind of housing unit you now live in?

		<u>Apartment/ Duplex</u>	<u>Detached single-family home</u>	<u>Mobile home</u>	<u>Townhouse/ Condominium</u>	<u>Other</u>	<u>N</u>
Overall	2023	20%	70%	2%	5%	3%	953
Age	18 to 34	42%	49%	3%	5%	1%	242
	35 to 49	28%	61%	2%	4%	6%	213
	50 to 64	7%	84%	1%	3%	5%	248
	65 and older	5%	84%	2%	8%	0%	248
Children in Household	Children in household	17%	77%	2%	3%	1%	253
	No children in household	21%	67%	2%	6%	4%	698
Employment Status	Employed full-time	19%	73%	1%	4%	2%	491
	Employed part-time	10%	79%	1%	7%	2%	101
	Retired or not working	21%	69%	3%	5%	2%	297
	Unemployed	49%	38%	5%	0%	7%	48
Gender	Men	17%	78%	1%	4%	1%	442
	Women	23%	63%	3%	6%	5%	473
Home Location	Open country or farm	7%	90%	1%	1%	1%	409
	In a suburban setting	21%	63%	3%	8%	4%	367
	In an urban setting	52%	34%	1%	8%	5%	168
Household Income	Less than \$45,000	42%	47%	2%	4%	4%	190
	\$45,000 - \$74,999	34%	54%	2%	2%	7%	217
	\$75,000 - \$99,999	5%	82%	4%	9%	0%	124
	\$100,000 - \$149,999	4%	85%	0%	10%		163
	\$150,000 or more	2%	96%	0%	2%		140
Household Size	1 Person HH	40%	38%	4%	8%	10%	144
	2 People HH	18%	75%	2%	6%	0%	437
	3+ People HH	16%	79%	2%	3%	1%	355
Level of Education	High school or less	26%	64%	2%	5%	4%	299
	Tech school/Some college	20%	70%	1%	3%	6%	258
	College graduate	20%	70%	3%	6%	0%	231
	Postgraduate work	10%	81%	2%	6%	1%	163
Own or Rent Home	Own home	2%	89%	3%	4%	2%	693
	Rent home	74%	13%		8%	5%	201
Region of State	Central Vermont	16%	75%	4%	1%	4%	190
	Chittenden County	21%	62%	4%	12%	2%	257
	Northern Counties	20%	76%	0%	2%	2%	214
	Southern Vermont	23%	68%	1%	4%	5%	285
Years Lived in VT	10 years or less	27%	58%	2%	12%	1%	166
	11-20 years	15%	82%	1%	2%		140
	More than 20 years	20%	70%	2%	4%	4%	644

Q17: Whether or not anyone in your household gardens, do you have a yard or outside space on which you can garden?

		Yes	No	N
Overall	2023	83%	17%	939
Age	18 to 34	56%	44%	242
	35 to 49	87%	13%	213
	50 to 64	96%	4%	247
	65 and older	93%	7%	236
Children in Household	Children in household	88%	12%	251
	No children in household	81%	19%	687
Employment Status	Employed full-time	80%	20%	491
	Employed part-time	91%	9%	98
	Retired or not working	90%	10%	288
	Unemployed	63%	37%	48
Gender	Men	86%	14%	439
	Women	79%	21%	463
Home Location	Open country or farm	93%	7%	399
	In a suburban setting	81%	19%	364
	In an urban setting	62%	38%	168
Home Type	Detached single-family	96%	4%	653
	Apartment/Duplex	47%	53%	192
	Mobile home	75%	25%	19
	Townhouse/Condominium	58%	42%	46
Household Income	Less than \$45,000	68%	32%	180
	\$45,000 - \$74,999	79%	21%	217
	\$75,000 - \$99,999	86%	14%	122
	\$100,000 - \$149,999	92%	8%	163
	\$150,000 or more	90%	10%	140
Household Size	1 Person HH	61%	39%	144
	2 People HH	82%	18%	427
	3+ People HH	92%	8%	352
Level of Education	High school or less	87%	13%	291
	Tech school/Some college	77%	23%	256
	College graduate	79%	21%	230
	Postgraduate work	92%	8%	162
Own or Rent Home	Own home	94%	6%	680
	Rent home	46%	54%	201
Region of State	Central Vermont	87%	13%	188
	Chittenden County	85%	15%	256
	Northern Counties	79%	21%	205
	Southern Vermont	81%	19%	283
Years Lived in VT	10 years or less	72%	28%	164
	11-20 years	88%	12%	138
	More than 20 years	85%	15%	634

Appendix B

Q3_8_TEXT: "What does your household do with food waste - Something else: please describe" - Other - Text

- All fruit and veggie scraps go into ziploc bags in the freezer, and when enough is stored, it is used to make soup stocks. THEN it is composted after being boiled down.
- Allow wild animals to eat
- Any rotten garbage gets put in with trash.... a minimal amount. Most is fed to livestock/pets or composted.
- Bones go in the trash
- Bring easy food waste to compost to the backyard bin. Save up meats etc. to bring to transfer station.
- Casella! waste told us no need to separate!
- Compost Can smell badly or attract pests if not done well: first questions were either did or didn't. Your questions assumed that properly handled waste either did or did not "smell, etc. there always some flies and other organisms on/in composting waste., even if done well. They are part of the process.
- Compost vegetables, freeze meat, fat etc., and put in garbage on garbage day.
- Countertop composter
- Dumpster bears around my house unsafe to compost
- Either in the trash or backyard pile
- Feed it to the bears when we intermittently re-start composting. The bears get used to it as a potential food source, bear-human interactions increase while fear of people decreases. Bears end up dying due to no fault of their own.
- Feed the crows and ravens
- Feed wildlife
- Flush in the toilet
- Flush more liquid food scraps down toilet
- Food scraps are set aside and I pay for a composting service to pick it up weekly.
- For lower-income individuals living in confined corners it has only decreased their happiness. The compost smells and attracts rodents and insects. In some cases, it leads to unsanitary conditions.
- Have a backyard compost for some food scraps and haul some to a collection site.
- Home composting is not an option for our domestic footprint. I am a retired degreed Agronomist and Ag Engineer.
- I also have an outdoor compost bin.
- I also put waste in the trash at times. Come arrest me.
- I am a landlord, and I have tenants. While I compost, and I give them compost buckets, and I give them the opportunity to empty their buckets in my compost pile, they usually put food

scraps in the trash. I really don't have a way of enforcing this, and I'm not going to evict them over it.

- I bring it to a friend who has a big composting system set up for their garden.
- I compost all scraps in a small in-house compost jar with biodegradable bag, when full I pull out, tie tight and place in freezer in basement. Every Tues I pull out of freezer put it in larger compost bucket we buy from town and put out for pickup with recyclables! Very easy, no smell
- I compost all vegetable and bread matter, but not leftovers meal scraps
- I drop it off at the compost piles at the dairy farm I work at.
- I have a mini composter (Lomi) in the kitchen.
- I have trash pickup and put garbage in a recyclable bag. We can't hang onto the garbage as it is because of flies when it's warm. Too many bears in the yard so composting is OUT!!
- I home compost all but meat scrapes and bones which I take to city composting.
- I only compost veggie scraps at home, meats and other foods go to the compost at the transfer station.
- I throw fruits and vegetables in the woods. Anything else goes in the garbage. This whole law is just another progressive move to control every aspect of Vermonters' lives.
- I use an Airthereal Revive kitchen composter
- I was composting, until I got maggots in my indoor compost bin and I had an explosion of flies. I'll bring it back inside in a bit but for now I'm just throwing my food out until the weather cools off a little.
- I would like to compost at home but don't have the room. My town took away the bins as they said it was too expensive
- If I composted in my backyard, I would attract skunks like WHOA...like my many neighbors who are fueling the skunk problem in this neighborhood.
- It's chicken food
- Leave non-compostable food for wildlife at the edge of our 3-acre lot.
- Leave out in woods for wild animals to eat.
- Let the wild critters enjoy, before it eventually rots
- Lomi device that composts on the tabletop
- Lomi tabletop composter
- Meat and animal-based scraps go in trash as they should
- Meat products in trash; not able to compost safely in backyard composter as attracts bears to yard (has before)
- Meat scraps should not go in a vegetable, compost, and therefore those go in the regular trash.
- Mix of pet and composting
- My husband and I used to set food scraps aside and took them to the collection site maybe once a month but haven't been able to do that since we moved to a smaller area

- Non-compostable food scraps, such as bones from meat, or seafood shells, we throw out into a field.
- Not meat scraps, only plant food goes in compost.
- Place in woods for wild critters
- Placed in larger compost containers to be picked up by haulers.
- Put in a brown paper bag in the freezer and then bring it to the transfer station when I bring my trash
- Put in food digester
- Put it in a bin in the freezer
- Put it in an electric composter which dehydrates and grinds. Doesn't seem very environmentally friendly but we have a lot of bears so can't compost outside and have no pick-up in our area and limited drop off options
- Put it in an open pile that also has lawn and garden waste
- Put it in the compost bucket supplied by an independent compost service
- Put some of it out in a location far away from buildings to keep skunks and coons from bothering garbage cans and animal feed.
- Recently switched from backyard composting to transfer station drop-off due to frequent bear visits
- Scatter over my land for wildlife consumption
- Scraps and inedible parts go in the worm bin, rotten food goes in the woods.
- Set aside for composting with community composting (private paid service but not a waste hauler) pickup - completed compost stays in the community on local farms and participating households
- Setting aside for community composting service (private company, not a waste hauler)
- Since we live in a senior living community, our compost goes into an attractive small bin on our counter and is then transferred to compost bins in the garage. It is then picked up on a regular basis.
- Some goes down disposal and some goes to compost bin. In winter all goes down disposal.
- Some often waits in the freezer until the three hours per week our transfer station is open
- Some scraps we toss into the high grass to compost or be eaten. Our yard is mostly high grass/wildflowers and backs up to the woods.
- Some things I toss into the woods like wrinkly tomatoes or soft apples
- Sometimes I just leave it in the sink until it's so freakin nasty I have to call in a swat team to get all the flies out
- Sometimes compost and sometimes just put it into the trash
- Sometimes I freeze it and drop off a local composter
- Sometimes I save it for other people's gardens
- Sometimes throw stuff in woods like fruit cores, live near woods.
- Sort with trash to go to dump.

- Take it with other trash to the transfer station serving our NH summer place where it is not an issue.
- The bones and other meat waste goes in the trash. The rest gets composted
- Throw a lot of it outside the back door for crows
- Throw into woods for wildlife to consume.
- Throw it in a compost bin that NEVER get turned over so it's essentially a garbage pile! \$100 for a bin that rotates, the labor to sort and carry the compost away from the house is just a fools hidden tax. \$500 for a counter top "automatic" composter that won't handle the volume of an average household is a ridiculous burden for the average family.
- Throw it in the woods (but not a specific compost pile)
- Throw it in the woods for wild animals
- Throw it into the woods for wildlife to consume.
- Toss in woods when I can
- Toss it in the woods
- Toss on the side of the road.
- Use a Food Cycler (an electrical appliance that dehydrates and grinds up food scrapes).
- Varies by type of food & season
- Was a combination of personal compost bin and town compost for pickup, until I got sick of cleaning maggots out of the town bin.
- We are aspirational composters with a purchased bin in yard. When it is -20 degrees and have to open a door that wastes fossil fuels on reheating house and booting up to go to compost bin, defrost door to open, and put in a quart of compost- we don't do it. Most folks we know are "environmental conscious" people and they are also aspirational. I will admit too many barriers for our household to do consistently
- We are using an amazing dehydrating kitchen composter made by Airthereal.
- We compost it in the spring summer and fall. feed it to the worms in the cellar (in a worm bin) in the winter
- We compost most fruit and veggie scraps but have to dispose of meat and dairy in the regular trash.
- We compost vegetable matter at home, but leftover meat and bones we take to the transfer station.
- We do backyard and transfer station
- We have a farm so I collect the scraps and put them in a manure pile which is eventually spread in the fields.
- We have a worm compost system at our home in North Carolina and it is highly effective, but I believe the long Vermont winter would require us to do that in our garage which would not work as well.
- We have an electric composter
- We purchased a Lomi food composter for plant food scraps. We take animal food scraps to the transfer station

- We put them outside for wild animals and birds.
- We use a green compost cone we bought from cs wd years ago. It works great except sometimes in the winter.. which is natural. It would be great if the cone could be made more public and affordable.
- Whatever pleases me at the moment. Ever heard of The Constitution? There's these pesky things called freedom and liberty. I know it's a bummer for your moronic agendas, but that's the way the cookie crumbles?
- Whatever works at the time of disposal
- Wild animals and Birds get the scraps thrown into woods. Never meat.

Q4_6_TEXT: "Which best describes the size of the container your household uses to set aside items for composting or animal feed" - Some other size - Text

- 15 gal receptacle furnished by the waste hauler
- 2 large composters. About 15-20 gallons. They rotate
- 27 gallon tote
- 3 gallon bucket
- 3'x2' cylinder
- 35 gallon drum
- A cereal bowl
- a purpose-designed composting container that is maybe 10 gallons, that we bought.
- Also have a second bucket in the freezer for items that can't be composted at home.
- Also use a bag in the fridge for bones, citrus, etc. that I don't put in my home composter but is taken to the transfer station
- Also use a smaller container quart size to put mostly veggie waste in for red wiggled worms kept in garage May- October and in cellar when cold out
- And then, when that's full, it goes into a large container to be picked up for the town recycling center
- B in the kitchen, E in the garage so we can store it for the week
- C inside home, taken to a large pile in backyard
- Depends on how much I have. Sometimes it's the top to a yogurt container, other times it's a tea tray worth.
- Don't
- Don't use a container.
- Don't use one.
- Food is taken immediately to large compost bin outside, we don't have a separate container inside that we use
- For our own compost pile, a 1-gallon container is used in the kitchen. For the material to be sent to the transfer station, a 1-gallon container is used in the kitchen, which is transferred to the 5-gallon bucket in the shed before taking it to the transfer station.

- Give directly to dog.
- Goes out at the moment.
- Halfway between 1/2 gallon and full gallon size
- Have a composter
- How often?
- I compost plant matter. I put compost in a bowl and take it out about 2 times a day.
- I DO NOT COMPOST. It's pointless.
- I don't. I just give it to the dogs or throw it away.
- I have 5 compost piles in various degrees of degradation. I have a large uncovered pile which has been sitting for a year which is ready to spread on beds. Two containers which will be emptied into these. One bin with this year's waste which will sit for a year. One empty bin which will be used this winter.
- I think it's 3.5 gallons. We put kitty box pickings in it too. We save the coffee grounds for the flower garden.
- I use both c and e. C is in the kitchen and E is in the garage.
- Inside, C, then the compost bags are taken outside to a 5-gallon bucket until they go to the compost drop off.
- Large two-barrel system
- Little bowl in house, dump into one of two outside containers: one is wire enclosure, one is closed black plastic container
- My compost is immediately fed to chickens or goes in a bin. It isn't stored because it stinks.
- N/A I throw it out on the lawn, for the most part, except vegetables which few animals will eat. Those are thrown in the woods farther from the house. Held in a grocery bag until grass is dry
- No container
- None
- None
- plastic grocery bags
- Probably about 10 gallons
- Quart for chickens 2 gal for backyard compost Multiple gallon ziplocks for meat/bones etc. to freeze until transfer station day
- Quart size containers, can be up to two a day depending on produce cleaning
- Rolling cart purchased from Windham Solid Waste for about \$40.00. 34" tall x 14" wide. It has a strong latch that prevents (nearly always) racoons from opening it. A bucket with a circular lid would be almost impossible for me to open, due to severe arthritis in my hands, nor would I be able to carry or drag it to the end of our driveway.. Rolling bin is outside by the back door. We keep a small container on kitchen counter & empty it frequently. I think the bins should be provided free or at very reduced cost to seniors (I am 70) & anyone else who would struggle to purchase one. The savings in municipal dump fees, as food garbage was taken out of the system, would make up for reducing cost to home user.

- Size c, we also have a size e tote outside where we collect the smaller bags for disposal farther out on our land.
- Size widely varies from week to week. We compost all we can at home and take citrus peels, bones, etc to a transfer station in up to a 5-gallon container
- Special compost bucket.
- Then transfer to five gallon bucket for pickup
- To avoid smelling up our home we take them out immediately after eating when we have compostable stuff, because bins get slimy and nasty and attract raccoons and bugs
- Two week cycle
- Usually whatever bowl we have handy.
- We do not set aside food scraps. We throw away of free to dogs immediately
- We have a 13-gallon kitchen trash can that we use solely for compost.
- We have a large metal trash can in the garage that we collect over a week or so. We have a 2 gallon container in the house by the kitchen sink and empty that into the large trash can about 1x day
- We have two that are about the size of C. One is for the backyard compost (peels, coffee grounds, etc), one is for the municipal compost (chicken bones, spoiled food, etc)
- We keep a 1- or 2-gallon container in the kitchen, move that to larger containers in garage, then to the transfer station
- We live in a condo. The workers built a shed to house the compost bin but the problem is that bears keep on breaking into the shed even though it is sturdy. I agree that composting is a good thing to do but don't know what the practical solution is.
- We put compost in paper bags in the freezer so it doesn't smell. When it's full we move it to a big green bin(s) in the garage. When those are full we take them to the compost bins at the dump.
- We put food scraps in compostable bags and freeze them until we take them to the transfer station
- We take right out to compost heap
- We use a combination of C for inside (daily scraps) and E for outside (weekly accumulated scraps).
- We use multiple containers. We have a small container about the size of a half-gallon that we keep in our sink. We have two other containers that are outside, near the door to the back yard. One is about 2 gallons and the other is 5 gallons. We empty the small container into the larger containers and then empty the larger containers, as needed, into the compost bin.
- We use old 32-ounce yogurt containers
- We use three compost container all about the size of a gallon milk jug.
- We use two containers. One for the chickens and one for the compost pile
- We will just carry the items outside and drop them in the pile. We don't put them into a bin.

Q13_5_TEXT: "Which method(s) do you use for composting" - Some other method - Text

- About one third are given to worm farm
- Add the few that don't go to our chickens to the pile of stuff that we clean out of their barn- basically manure and wood shavings.
- And then take it to the co-op once a week
- Big veggie scrapes like corn husks and cobs go to our household garden pile in summer. Everything else goes to Town curbside composting.
- Bokashi bran in 5 gal buckets for 2 weeks and then buried in compost pile.
- Bring scraps to transfer station when we bring our trash
- Chicken food
- Deep woods
- Drop off
- Dump in our woods far from the house
- During the winter I use a composting dehydrator
- Electric unit that dries and grids scraps
- Fed to chickens
- Feed to chickens
- Feed to dog so I don't attract bears
- Feed to pets or trash
- Five-gallon bucket
- Food scraps collected in trash room in my apartment building, one on each floor
- Foot pedaled waste can we have in our kitchen. Attracts fruit flies, Messy and stinks.
- Garbage disposal in sink
- Goes in a wheelbarrow in a barn that also has wood shavings. Eventually gets mixed in with the manure pile. I rent from a farmer who asked me to do this rather than keep a pile outside.
- Green Cone
- Green Cone food digester purchased through the county solid waste alliance
- Half taken to the transfer station
- Have a bucket in the garage
- Have inside collection that is frozen until pickup by trash hauler
- Heap with cedar pole side: two piles side by side.
- I do not compost the animals eat it all
- I do not compost!
- I do not compost. Your survey should have a button for this option on every page?
- I feed the dogs as I go. Throw the rest away.
- I have a 5-gallon bucket I keep in the freezer so that crap doesn't smell. It gets picked up 2x's per month and it's a pain in the ass....

- I have a large 'fenced' area for barn waste and household compost that can't be fed to poultry.
- I have a Lomi composting machine.
- I have both chickens (in a run) and a worm bin and divert the food as is appropriate. In the winter the chickens may get less as it would just freeze. I also compost the chicken run dirt (yearly) and make leaf mould.
- I have horses and compost everything in the manure if it's not suitable for the chickens
- I live in a continuing care retirement community with outdoor bins for food waste that are picked up for composting by Casella.
- I place the scraps in a small bucket in the garage provided by the waste hauler for pickup once a week.
- I put 13-gallon bag in a 5 gallon bucket with a lid and place the compost in the bag. Once a week I pull the bag and transport it to the local transfer station. It is then composted and each day I buy compost from the operator of the transfer station for my garden.
- I put directly into my fenced garden
- I put in a plastic bag in the freezer
- I put in municipal provided container to be picked up once a week
- I put it in a 5 gal bucket and then take it to cans left at the park for composting food scrapes.
- I put it in a bin collected by a waste hauler
- I put my scraps in Biobags in the refrigerator until I transfer them to a large container outdoors that everyone in my building uses.
- I put scraps in a 2-gallon bucket in the garage.
- I put scraps in a 5-gallon bucket with a lid in my garage that is picked up once every 2 weeks
- I put scraps in a bin outside my condo specifically for compost scraps; it is picked up weekly.
- I put scraps in a stainless steel 1 gallon container in the kitchen until that's full and then we remove those to a 2-gallon container plastic container outside that gets picked up once a week.
- I put scraps in a stationary bin purchased by our property manager for two apartment buildings.
- I put the scraps in a bucket inside our garage
- I put the scraps in a covered 5-gallon bucket which is then taken to a transfer station by my son when it is full.
- I put the scraps in compost and then waste hauler picks up
- I put the scraps in my freezer until I'm able to take them to a garbage can (used specifically for compost) that Casella (waste Remover) picks up weekly.
- I put the scraps into a small covered bin set beside the kitchen sink
- I put them in my freezer
- I store them in the freezer until I bring out to the bin to be collected by the hauler
- I take all my food scraps to the composting bin at the transfer station (aka dump)

- I take the vast majority of scraps to our local solid waste district's commercial composting station.
- I throw into the wild parts of my property
- I throw them in the woods
- I use a compost container that is picked up once every two weeks.
- I use a smaller container inside and when full empty in larger container outside.
- I use an old wooden form that was constructed to hold compost, but it is pretty decrepit now so there is a pile inside the remains. :-)
- I use several wire enclosures that I turn annually and the resulting dirt is for garden use.
- I used to compost at home in a stationary bin that I purchased. That worked great for years, but I'm a widowed empty nester and now find it easier to either take to collection point in town on Saturday or put out for hauler
- In a 5-gallon bucket which is picked up by hauler
- In spring, summer, fall: We put scraps in a barrel composter outside that we manually turn as needed. In the winter, we use an electric composter and put the result in a bucket until the spring.
- In the winter we use a worm bin in the basement
- Indoor electric food composter. Works for small household, by-product tossed in woods or garden, doesn't attract bears which are close neighbors
- Inside bin that I put outside for the waste hauler every other week
- Into our Food Cycler
- It is in house until full then dumped I to a compost bin for waste hauler
- Just throw it in the trash
- Livestock feed. Whatever can't be fed to them gets trashed.
- Meat and bones and fat go to transfer station compost
- Most gets tossed out the back door. Corn husks, tomatoes and pepper hulls get thrown into the woods farther away from the house, all within the same general area where we don't walk
- Mostly it is in a stationary bin outside. Meat scraps go in the freezer and then I take to a transfer station. Egg shells go in the trash.
- Municipal transfer station
- My outside unit used to rotate... after a few visits from bear it doesn't function as it was designed
- My property is a forest. I distribute organic waste around trees. Some gets eaten by animals, the rest rots in peace.
- My trash hauler provided us with a bin
- None
- Our town is the ONLY one in Vermont that hires a garbage hauler (Casella) and pays for it with town taxes. Biweekly "organics" pickup is included. But the containers provided stink so badly after a few days we can only use the service in the dead of winter. The rest of the

year we essentially dump the food scraps (except for meat) in a garbage bin/pile that produces more methane than a dump would.

- Outside bin in a shed for condo
- picked up with trash
- Place food in a pile and agitate with shovel once a month
- Placed in a bin outside for pickup every 2 weeks
- Put in bin Condo Association bought to be picked up by commercial hauler
- Put in bucket town provides. They pick up once a week. I keep my bucket in garage.
- Put inside a covered 5-gallon pale usually filling up 2 every 2 weeks keep outside then to drop off station
- Put scraps in a bin on my kitchen counter
- Put scraps in large trash can with lid. Picked up by hauler.
- Refrigerate in plastic bag until taken to neighbors chickens
- Rolling bin purchased from town of Brattleboro for about \$40.00
- Scraps are put in a container that hauler provides
- Scraps go in a 5-gallon container outside that gets brought to transfer station every Saturday
- Scraps go in a container that fits into an electronic unit that heats, grinds and dries the scraps, creating compost
- Scraps in the freezer, in a bowl lined with compostable bag; dump at transfer station every week or so.
- Scraps live in the fridge until I drop them off.
- Small container on the counter that holds compost bagels, when the bags are full they go outside to a 5 gallon bucket until they are taken to the compost drop off.
- Spread directly on raised beds in the fall for overwinter composting
- Those items that go to the commercial composter are kept in the freezer in a bucket.
- Throw in the woods
- Throw scraps behind house or in trash
- Toss some food waste on the side of the road. The rest is put in the trash.
- trench method - directly into the garden (in spring/summer/fall)... first winter in this house, winter method is TBD
- Two stationary bins side by side.
- Use a container in the garage and bring to local farm
- Vendor
- We fill 3 5-gal utility buckets with compostable materials and drop them at a transfer station monthly.
- We have 3 methods, pets, rotating composter, and a bin to go to the transfer station (meat, corn cobs, pits)
- We have a bucket in the kitchen

- We have a community compost bin for our HOA.
- We have a green cone digester for bones, fats and dairy scraps.
- We have a small compost bin by the sink, when that becomes full or full of fruit flies, we take it outside to our large compost pails and take it over to the Vermont Compost Company for them to use.
- We have three spinning units that we can rotate both physically and rotate from season to season. Two are always biodegrading and one is always for new waste.
- We keep bin in the basement because of bears and put it out once a week for municipal composting.
- We put our scraps in a bio-bag
- We throw them over our bank to create dirt to sustain it and stop it from eroding as much
- We use a Lomi in-home composter, we then bring those bits outside in a unit outside that turns. We then use it in our garden and yard.
- We use a small compost bin under the sink that has compostable bags and when a bag is full we transfer it to a larger can in the garage. That can is then put out for pick up with our other trash when full or near full (we are charged per pickup). There are insect problems in warmer weather but we can't keep outdoors because of bears.
- When backyard compost is full we store in 5 gallon pail in garage then take to transfer station

Q16_5_TEXT: "Which of the following comes closest to the kind of housing unit you now live in" - Other - Text

- accessory dwelling unit
- Apartment attached to a business
- Apartment attached to a house
- Apartment attached to house
- Apartment building, 9 floors.
- Have a tea gal apt
- House
- Houseless
- I house
- Leased apartment
- Mobile home in a park
- Multi family home that I own and rent out apartments
- On top of full basement
- Residential care home
- Small cabin
- Tiny house

- Two family home

ENDCOM Thank you for participating! Before you submit your responses, do you have any final comments or feedback that you would like the researchers to know about?

- 4 adults, 2 parents & 2 college students who live mostly on campus. We compost everything except egg shells. We feed meat scraps to dogs & cats, all other scraps go to the poultry except egg shells because we don't want to feed their own egg shells back to them for a variety of reasons (germs & encouraging egg eating mostly). I was definitely aware of Vermont's phased approach to composting regulations & find most other Vermonters are similarly aware. I work in Chittenden County & I know that composting there is a lot more complicated than on my rural homestead with abundant space from my home & my neighbors' homes.
- Although composting can be more effort, what we save from going to landfill, and what can be feed to animals and used in gardens private, public or community is well worth it.
- Although I'm a committed composter, many of the people in my building don't compost and there's little information that's sent to us explaining why it's important. This might improve participation.
- Are there any places where I can learn how to properly compost, or resources to help me out?
- As for composting. All households connected to public sewer should put food scraps down to the sewer plant to be turned into electricity via organic digester then that compost can be sold to farms or consumers or given back to citizens. Organic digesters should be part of every municipal septic plant. Just as every MRF should have a waste plastic pyrolysis plant making clean diesel fuel and natural gas from all the waste films that end up in our landfills USA does a horrific job of creating sustainable industries from our waste products
- As with most of what Vermont seems to try to do, composting is just made into much more of headache than it needs to be.
- Bears are a big issue
- Bears have become a real problem in Vermont and I've heard of many neighbors who've had their compost bins attract bears.
- Bears. I've tried and tried to set up a bear proof system for composting. I retire in 2024 and this is on my to do list
- Bottle return does more than food waste, should change it to include all bottles.
- Brattleboro allows us to compost pet waste as well as food waste, which is great!
- Bring back the bins
- Can I receive a copy of the results?
- Cannot compost certain times of year because of bears in the area

- Capturing food waste is easy. Maintaining a home compost with the correct inputs that actually turns scraps into soil is not easy. How can we keep people from throwing away food scraps at public receptacles such as gas stations?
- Clean up your descriptors for race/ethnicity. Race is a social construct and has nothing to do with biology. White skin is not a thing and I'm sure most people you would consider Caucasian aren't from the Caucasus. See American College of Medical Genetics for a good way of doing this. Categorizations like yours drive me nuts.
- Composting not safe for many with bears and living in wooded yard
- Compost pick up would be helpful - putting the bin on the side of the road for pick up would be helpful and I bet more people would participate. We currently just have a heap/pile that we throw compostable items on and then cover it with dirt or leaves. We use our compost for gardening and for our grass. We also sift through the compost pile for worms to go fishing.
- Compost piles are difficult when there are bears around. I wish it was easier to have a compost pile.
- Compost was pushed upon Vermonters by the Burlington bureaucrats - same with the discontinuation of plastic bags and straws. The current administration is very motivated by self interest and pander to global warming freedom fighters. What happened to Vermont being for Vermonters?
- Composters are expensive. Lower the cost and more residents will participate in composting.
- Composting and recycling saves us so much on trash volume and fees! We only throw a bag of garbage once each season (4x per year). Good especially because trash disposal in Vermont is expensive compared to other states
- Composting as a requirement is not practical and neither is this Clean Fuel business.
- Composting biggest challenge for me is the animals it brings into the yard (bears, skunks, raccoons and coyotes.
- Composting food scraps is a great idea for homes that have a lot of food scraps. For a family that has less than a quart of scraps per week it is more hassle than helpful.
- Composting for 40 years
- Composting in an outdoor pile (our first method) drew RATS for the first time to our property. We use a 5-gal drum and are so glad our local transfer station accepts food scraps. I can understand why people are hesitant to compost. Kitty litter containers make great weekly containers for food scraps! Towns should GIVE residents the supplies to compost easily and do more education at the town level.
- Composting is a good thing to be doing. It does smell bad and you have to stay on top of it.
- Composting is a great idea but is difficult for me to do. Glad I have dogs to help.
- Composting is a great idea until bears roll everything over and hang out in the yard all day

- Composting is easy and good for all.
- Composting is easy and great for your garden. Everyone should try it
- Composting is easy and we save a ton on potting soil in the spring!
- Composting is easy, and it works well - as intended
- Composting is EASY. Once in a while the bears tip the bins, mostly in the late fall for pre-hibernation snacks but we don't care. Sharing is fine as long as we cover the smell and use cayenne pepper we don't get much "snacking". Our house is not a feeding station and it's completely manageable with wildlife...
- Composting is fun!
- Composting is harder in an apartment, and at least in my building we're not incentivized to do it, because we use a dumpster and therefore our trash output is basically unmonitored. Somewhat related is that if you need to dispose a hazardous material, the place to do that is only open May to October, from 8:30am-11:00am on Fridays, *and* you have to pay a \$10 fee to dispose the material. At that point you're just going to dump it down the sink. I am not generally impressed by municipal trash disposal policies.
- Composting is too much work for Seniors.
- Composting of meat scraps and other things that don't go into my home composter make it more expensive and inconvenient to do.
- Composting produces some rich soil to add to our garden for growing tomatoes and herbs.
- Composting requirements have created major issues with wildlife. Bears, raccoons, fisher cats, etc. visit regularly. Commercial compost options are expensive and don't stand up to bears! The law was extremely ill-conceived! After the bears tore apart two commercial compost bins we gave up. I screwed together some old pallets and we just throw in the scraps for the bears to enjoy. We call it the Bear Lunchbox!
- Composting Rocks!
- Composting should be a personal choice. If the state chooses them can do so only over businesses
- Composting through our trash collection was going to raise our bill by \$15 a month so we decided to upgrade our compost situation from a pile to a stationary bin. If it is legally required, the trash service or state should provide the means to do so.
- Essex Junction is now separate from Essex so your list of cities is lacking
- Except for my service time I have lived within fishing distance of the Connecticut River on one side or the other my whole life.
- Food scraps include meat, with bears & other animals we've been told not to compost meat- could be useful to specify this
- Forced composting is a waste of time and money coupled with an invasive intrusion upon my home perpetrated by whack job environmental Progressives

- Fruit flies can be a problem if compost is kept on the counter until put out. I keep mine in the fridge, which pretty much eliminates the flies.
- Get compost put into trash
- Govt is accelerating climate change, resulting in global deaths
- Great subject!
- Had problems with rats. Neighbor called health officer and said I had food scraps (didn't) and feeding the rats. Removed over 1000# of wet compost. Negative for food scraps. Not doing THAT again until they figure it out. 3 years ago they were talking open composting! Get it together please!
- Hardest part of composting is bear mitigation!! Other critters have never been a significant problem.
- Have only a small compost bin that has to be mixed with a shovel, that being the reason for most material being taken to transfer station
- Have to get resisters to join in. I know several folks who just throw everything away, including recyclables. Some type of enforcement, extra charges, something to push those who don't care. It's so discouraging, I try to teach those who resist. Plus. Have to target apartment buildings and multiple dwellings, landlords don't provide so more people at one address don't have to do it. These hurdles have to be tackled.
- Having a regular pickup of food scraps, funded by the state or each town would make this more workable. Many people really don't have a place to do this and running to the transfer station with the quantity a person who cooks "from scratch" accumulates would be onerous and one more time to fire up the ol SUV or whatever. Keeping buckets of garbage around is not a good practice either. I favor composting but as I age it gets harder to hike out through the snow, turn the pile etc. it would be better as a public utility. Gardeners of course make good use of it.
- Here in Brattleboro we have had mandatory compost & recycling for about eight years (I think) this keep the amount of household trash out of the system we have been able to organize all three categories with ease we put out compost & recycling every week and trash out every other week for pick up
- How about a survey about the failure of the Vermont legislators to honor their social compact with the Vermont taxpayers?? Flood preparation and mitigation spring immediately to mind
- I am happy to be given the chance to explain my composting to someone :p
- I am not sure that the value of composting is maintained by the current system of multiple gasoline-powered large vehicles that come through and pick up for people. Especially because there are multiple businesses, so we get at least three a week on the street, in addition to three different trash haulers. There should be one hauler of everything, one truck, once a week. Electric truck.
- I am so happy to live in a state that is considerate of our environment. I wish that every state would require, or at least encourage, composting as it is so good for the earth!

Our remote site state parks even have composting toilets in the woods and they are so much more effective (by using wood shavings) than outhouses are! Thank you for doing research on this subject.

- I appreciate the inclusion of more than two gender options, but it would be more accurate if multiple options could be chosen (e.g. both transgender and woman).
- I believe because of this composting issue, we now have rats in our neighborhood. Last winter and spring we caught nine on our property alone
- I believe composting is necessary and doable.
- I can compost most of my food at home because I am a vegan and so I only have plant based scraps—never any meat or dairy.
- I can only compost plant products at home. Before the law went into effect, I could compost animal products as well through our town compost bin. After the law went into effect, the town could not afford to maintain the community compost bin. No service is currently available for curbside compost pickup.
- I divert my food scraps into two streams: stuff good for chickens and stuff that chickens don't eat. The second goes to compost.
- I do wish that composting services were more accessible in our state for people. Right now it's costly so not everyone is doing it
- I do wish we had affordable compost pickup with our regular trash service. It seems silly to go separately to the dump.
- I feel guilty about not composting more because I have an area and can. If I were younger I feel that I would.
- I have a short-term rental unsit and even with detailed instructions renter are rarely able to properly separate compost recycling and garbage. I often have to spend time doing so for them
- I have composted pretty much all of my kitchen scraps since my early 20s, usually for a garden. I don't garden at this location because of cows.
- I have done this for years. Every spring I use compost to fertilize my veggie gardens.
- I have it easy to compost with the horse farm....also WEC our electric co-op uses several old dump sites to collect methane for power...if you really want to figure out the major issue of carbon pollution stop wasting your time on food scraps and cow burping.....the most under studied is Small, unregulated small engine equipment...mowers, leaf blowers, weed eaters. anything with a small engine....
- I have no information about composting. Our waste pick up company (Cosella) never mentioned a composting pick up and I haven't heard about the effect of having a composting bin on attracting animals or how much it saves the environment. Perhaps the increase in composting is associated with the sudden sightings of bears across Vermont?
- I just dump the compost in the pile. I don't turn it or do anything with it but it makes me happy and my trash doesn't smell. I wish more people knew how easy it can be.

- I keep container for food scraps in the freezer, put out in container for pick up once a week.
- I live in MA for 9 months before moving to VT, but before that live in NH for most of my life. I took a 5 day composting class with the University of Maine in 2013. Most recent "transplants" to VT don't know about the composting law. Many people still are not composting. Those who do may not be doing it well and therefore may be attaching animals.
- I live with family so I could do my own composting but I'm waiting until I have my own place, the family I live with doesn't compost & honestly I think I only know of maybe one or two people in my circle that actually do. I am a serial recycler, I'll save stuff to recycle it if I can't find a blue bin while I'm out, I want to compost it's not convenient yet enough for me not having my own place. Big trash companies have to provide bins or enforce it or the state has to step in or it will never happen, most people don't care unfortunately and some people still don't even recycle. They need to track trash & give citations & tickets unfortunately is the only way to across the board enforce composting & get recycling levels up.
- I lived outside of VT when I served in the army
- I love composting!
- I LOVE that Vermont requires compost collection. It's something I think should be required by all US communities.
- I moved from Vermont once in 1983 from Massachusetts, but I am originally from Tennessee.
- I put meat scraps in regular trash
- I started composting my cat litter and added the garden and food scraps as a natural enrichment.
- I think fossil fuels and polluting our oceans cutting our trees and emissions from cars are our biggest problems. But scientists have tried to warn us and we never listened. I fear it's too late. It's disheartening when politics get in the way
- I think instructions on how to compost on the TV might be helpful. Simple, easy...
- I think it could be a valuable question to ask if you composted before the law went live. It seemed like it was going to be a huge burden as the start date approached. We had not composted prior to the start date. Then we did. And now it feels crazy to throw food in the trash. The other side of this, and I don't know if it is discussed at all, is what's in the trash now. Without food scraps in there, it's almost 100% packaging for us. It's just so obvious now that there aren't layers of food scraps between the packaging layers now.
- I think that landlords should be required to provide a compost solution on site of your rental. I have to pay to drop my compost off at a site that is sometimes randomly closed and only open 2 days a week when it's actually open. It's pretty inconvenient and I think

I'm probably the only person in my 13 unit building that actually composts because it's not convenient

- I think Vermonters are conscientious about composting. We are required to compost and at my condo association we provided lessons and containers when the law was first enacted.
- I use a gallon ziplock bag to collect compostables. It works well and keeps the odor down.
- I used to live in Windham Vermont where I had an outdoor roller bin to compost. But for "hard" compost items I took to Londonderry transfer station. Things like meat bones, meat oil. Didn't want them in home compost- also they would attract bears.
- I want to vermicompost, but don't have room right now.
- I wish Casella would provide compost bins that we could put out with our trash on trash week.
- I wish more businesses in VT had a compost bin
- I would appreciate information about the exigence for specific surveys--why this topic, framed this way, at this time, for what purposes. Some of this information may be included in the informed release areas but I would imagine it goes beyond what is minimally required for those in terms of IRB.
- I would compost more if it was easier/closer to drop off my compost!
- I would gladly compost, as we did when I was a child, but we have bears in the area, and they are already getting into our neighbor's beehives. I'm not going to do anything to encourage them to come to my property. I see them walking the stone wall on the ridge above the house, and that's close enough.
- I would happily compost if there was a service that would provide a suitable bear/raccoon proof container and haul it away for an affordable price. Dumping food scraps in the disposal is a HUGE waste of water, and trying to get dead flowers in the disposal is absurd!
- I would have liked to see more questions surrounding what I compost. Because of where I live in a rural area bordering woods, I can only compost veg/fruit scraps. Nothing cooked in oils, no proteins. Those all still go into the trash because we don't have an option to have compost collected and we live too far out to drop it. I wish we could compost it all!
- I would love to compost more but living in an apartment where the landlord does never followed through with providing us a space to compost in responsibly has turned in to an issue. The transfer station is a busy place to be when it's open and its hard to tell when they aren't in a peak hour. Also during the summer the smell of the buckets we need to fill to bring to the transfer station summons the raccoons and those little folks while cute are strong and make a mess so keeping them out has been a losing battle.
- I would love to see the results of this survey. Are all us VPR listeners composting? Are the Fox News people composting?

- I'd prefer using a garbage disposal over composting but we have a septic system.
- I'm curious who sponsored this survey and how the results will be used.
- I'm moving out of VT because it is too expensive to live here.
- If composting is required by law, waste haulers should be required to pick it up for free, same as recycling.
- If composting was easier (there were more programs available, composting bins were provided by the trash collection company and picked up regularly) I would be happy to switch over to composting all food scraps. As it is right now, there aren't any programs readily available.
- If Vermont wants composting they need to provide the bins and service without additional cost to residences
- In the seasonal percentage of composting, I assumed you meant of the scraps set aside for composting as in an earlier question. Do not compost meat, fish, etc.
- In the summer I put my meat scraps out in the woods away from the house and in the winter I usually burn them in the wood stove.
- Interesting topic
- It doesn't go with the survey but how do I get in to UNH?
- It might be nice in a survey like this to distinguish between kinds of food. Like most backyard composters I do not compost anything containing animal, fat or dairy products. Lots of farms around here and I don't want rats.
- It would be a lot harder to compost if my building did not provide a bin on the premises and arrange for collection
- It would be helpful to educate more people and actually fine people for violating the laws, provide more assistance in getting people on board I'm shocked how many people residential and commercial are still putting all food waste in with garbage! Plus there needs to be more devices etc. that are insect (fruit fly) free and animal (bear, raccoon etc.) free, or ways to prevent also help in dealing with hard to break down items like avocado seeds etc.
- It's easy to feed scraps to chickens at my rental unit. I will be moving to second floor apartment with no livestock on property so that will not be easy.
- It's not difficult to compost!
- Keep up the good work- more surveys about community building
- Keeping compost away from bears is impossible!
- Living in the woods makes it difficult to compost due to the animals. We sometimes have trouble with them as it is. VT requirements for recycling is far too specific to be really effective. Most people don't comply as needed for the benefits.
- Living on a lake side where nutrient runoff is a concern, there are few places to locate a compost bin or green cone and not create nutrient runoff to the water body
- Love UNH granddaughter graduated from UNH
- My husband and I are both handicapped. Composting is difficult for us.

- No
- No
- No
- No thanks, it would take too much space.
- None
- None
- Nope
- Nope, glad I could help with your research.
- Nope.
- Nope. Totally enjoy your surveys.
- Not at this time
- One of the questions did not work. I was unable to select a choice. I have been composting my entire life.
- One question was confusing. Can't remember exactly which one but it was asking for percentages on a variety of items but the process didn't work.
- Our bear problems are a direct result of composting. We never had so many bears in the city before.
- People should not need to PAY to get rid of food scraps. Also there should be no carbon tax laid on the backs of Vermonters.
- Perform a survey that talks about the high taxes in Vermont.
- Please add Essex Junction to your list of municipalities! It has existed for over a year now.
- Please keep my answers confidential. I don't want the compost police showing up at my house :)
- Preferred not to give my age.
- Questions on composting may differ significantly from average due to: Recent migration of NYC residents to VT due to covid Previous history, time away, and time back into Vermont may cause significant outliers, due to covid 19 re-locations from large cities (e.g. New York City) and from other states.
- Regulated composting is stupid, creates more vehicle emissions and the composting that happens without methane capture (90%) is worse for environment than Coventry landfill with methane capture.
- Requiring everyone to compost is delusional, impractical, and hazardous to every community.
- Revolution is coming!! Or a civil war. Prepare!!
- Said in an earlier comment but though we used to set aside food scraps all the time, it hasn't been very feasible after moving recently. Also, even though it is technically the law to compost, it's a personal responsibility and not made very easy to comply with or that everyone even knows exists. And the more rural people are, the harder it is

- Saving our food scraps is not challenging. Maintaining a balanced compost pile is very challenging. Ours is mostly sludge, and it smells pretty bad most of the time. We understand this has to do with the balance of greens and browns/wet food and dry materials, but we just have not been able to make it work despite our best efforts. We continue to compost regardless.
- Should do more for soil and environment.
- Should not have to pay to compost if the government is requiring it
- So few options for the internet at a practical pricepoint. HELP!
- So glad you are addressing composting in Vermont. More Vermonters need guidance and services to make the law work as intended. Waste haulers need to provide better options and to advertise the process much, much more. Make the bins people put in their freezers for scraps that they then take to the dump on Saturdays, for example (easy, no smell) fun and colorful. Get people on board with creativity.
- Some of the food scraps is also thrown in the woods behind my house when there isn't snow prohibiting it.
- Stop with the racism, where we came from, we live here now, why does it matter. You are dividing us, stop it!
- Thank you
- Thank you
- Thank you for asking.
- Thank you for counting survey responses if I choose not to respond to a specific question. If a survey requires responses to specific questions to be counted, I do not submit surveys that invalidate questionnaires that require responses to specific questions.
- Thank you for the survey opportunity
- Thank you!
- Thanks for asking about this. I also am the president of two condo associations in Burlington. We compost and had the most engagement (and all positive) when we launched our compost activities for one association. We bought dishwasher safe bins for each unit, bought two stationary composters that filled almost immediately. We also contract with a commercial service to keep up with the need for 24 units. Many units also have garbage disposals.
- Thanks for asking!
- Thanks for asking. I want to know why people aren't curious about Dinesh Desusa's 2000 Mules Documentary? Newscasts keep saying recounts were correct but if there 50k invalid ballots, then their recounts are of no use in finding the truth. Going to polling place with valid ID can be accomplished within a short AMT of time for majority of Americans- certainly not racist. There is still absentee ballots available for informed or emergencies... just asking for fraud when ballots are mailed to everyone who was ever registered

- Thanks for developing a survey on this subject.
- Thanks for illustrating referenced sizes of household composting containers.
- Thanks for letting me participate!
- Thanks!
- Thanks!
- The 10% not composted seasonally is the coffee grounds we put in the garden.
- The app wouldn't let me enter the percent makeup totaling 100%
- The city of Burlington does not make it easy to compost; compost should be differentiated by fresh produce and cooked foods; more refined if possible would allow very rich fertilizer and generate worms.
- The compost totally freezes in the winter months and doesn't compost at all, the lid of it freezes shut! Otherwise you can either pay monthly for people to pick up your compost which doesn't seem at all good for the environment to have it driven around all over the place. OR place the stinking mess into your car, hope it doesn't spill and lug it to the drop off point. All these to make subpar compost because most people don't remove plastic stickers or check if things are truly compostable.
- The composting law is the stupidest thing I have ever heard of. Liberals run-a-muck!!
- The Coventry landfill, which I believe gets Franklin county's trash, is plumbed to capture methane gas to burn to produce electricity. With the big push for everyone to buy electric vehicles, I don't think that our electric grid is ready to handle this. The plastic bag and junk mail that I throw away won't make methane. No methane - no electricity - no charging my ev
- The landfill needs the food scraps to break down the trash. Proven facts Vermont is a liberal progressive hell hole
- The law is extremely frustrating. It's a case of a state mandate without providing funding to facilitate the mandate for communities or for individuals.
- The law to compost is stupid and is difficult for older adults and those who live in apartments. It is age-ist and impacts those who have less money, less space. A better approach would be to educate and promote this behavior. I have composted my whole life- but it makes me angry the state of Vermont feels they need to micromanage my food refuse. Who do you think you are. This is about as anti-Vermont as you can get. Ah yes, that's right, the people in Montpelier who make these stupid decisions aren't usually from Vermont. If they were they would have grown up with these practices and not feel some righteous virtual signally to mandate everyone do it. I am sure people like me won't take the time to fill out this survey.
- The plastic stickers on produce are really a drag!!!
- The question about education level is confusing. "finished AND received credit for"? If you didn't receive credit, you didn't finish. Was this meant to say "finished OR received credit for"?

- The question about how many kids I have in each age group was misleading, because at the top of the box, it says “ages”. So was I supposed to put the age of each kid in that group? Or the number of kids I have in each group? I put “1” in each box because I have one kid in each age group, according to the question.
- The question about what other media I regularly read/hear/see is such a wide-open question that I did not bother trying to answer it. Books, ebooks, magazines, websites, streaming services, and so on. Specific titles I don’t miss include Scientific American, Poetry, Science-based Medicine, Death Panel podcast, Conspirituality podcast, and many more. So, I consume media with a bias for reality, democratic socialism, mutual aid, progressive political possible policies, science, and speculative fiction.
- The questions seemed a bit skewed to encourage respondents to criticize the requirement to compost. It has great value despite minor inconvenience.
- The survey didn't accommodate well multiple means of composting.
- The trash can for recycling at the building I live in is on the next building’s property. It is a pretty far walk for most of the older and disabled people in my building. It certainly appears that I am one of the few making the trip. I think if each building had its own receptacle perhaps more would make an effort, or maybe people just don’t like fresh vegetables. I do.
- The vermin problem is very real. Since the composting legislation (void of meaningful communication), our household that has been composting successfully in Vermont since 2004, has discovered a record number of raccoons and Norway rats not ever before captured by our wildlife cameras strategically pointed on the compost bin. We no longer will utilize the compost for our gardens from concern over what diseases these vermin could carry and introduce to the soil.
- The very first question needed an I don’t know option, which is what I would have said. No idea how informed people are about the composting requirement.
- The wildlife couldn't be happier... never seen so many foxes, bear, skunk, mice, raccoons, deer, neighbors dogs... all rooting though the food waste in the back yard. Nothing like rotting, free food to keep them coming back for more, into the neighborhoods, by the heavy trafficked roads, instead of staying up on the hillside where they forage. I can't drop off food scraps often enough to make it Unfeasible to toss it in the back yard. Thanks Vermont Legislature!! Ever think of drivethru food scrap recycling in every town, where you toss it in from your window like a toll booth, and the State can collect/compost and create some methane electrical plant???)
- The word “should” is inappropriate when considering official policy because in our republic, the power resides with We The People and not with the legislators and appointees who serve us. Want more composting? Provide containers and convenient locations for emptying those containers. Provide a service...don’t try to make demands.
- There are definitely more important topics in the world right now

- There is a difference of the food that we compost. Cooked food goes in the brown bag in the freezer and then to the transfer station. Raw veggies; coffee grinds, fresh fruits; eggshells go in the back yard compost bin.
- There is a huge difference between composting vegetable matter (peels, husks, ends, etc.) and food waste that includes meat and oils. The meat attracts raccoons, bears, mice, etc.
- There is no mechanism for enforcement
- Thinking of reducing the amount we compost do to rats being seen.
- This law is absolutely ludicrous. Like a government body doesn't have better things to do than discuss what I do with my leftovers.
- To clarify, I live in an accessory apartment attached to the home of my son, his wife, and my 2 grandchildren.
- Tried composting until fruit flies laid so many eggs in our compost bucket it was disgusting!
- Vermont does not make composting easy. I do not have an option to have compost picked up. My neighborhood has skunks, raccoons, and other creatures that get into composting. VT should provide better options
- Vermont's composting law (unenforced and unenforceable) is one of the most ineffective, environmentally counter productive and burdensome pieces of legislation I have ever experienced. AND I have lived in Maryland, Oregon AND California (over 21 years combined) so I have experienced some REALLY STUPID environmental legislation.
- We 2 who live here were not in the military but were in Peace Corps & VISTA. Other forms of serving the country for similar time periods.
- We also use compostable diapers and baby wipes! Dyper brand which you ship back to the company for commercial composting.
- We are certainly not opposed to composting, it's just that we have a hard enough time keeping critters out of our trash. Every bit of organic material goes back into the soil via disposal.
- We began composting long before the law simply to keep our trash from being stinky.
- We can't put dairy or meat in our backyard compost and our trash and recycling hauler, Casella, doesn't pick up compost. We would like to be able to compost ALL of our food waste.
- We composted when we lived in New Hampshire, and found that it was a liability when we put the house on the market because prospective buyers were worried that the compost bin (which was close to the house) might have attracted mice or voles, etc. We also found that we ate too many of certain foods (e.g., bananas, with peels that didn't decompose well) to create a balance in the compost. The company that picks up our trash does not offer the option of separating out food scraps. And I have seen no explanation for why food scraps in the general trash wouldn't, for example, help with

decomposition at the landfill that the trash is headed to. In short: I'm in the dark, and we need a LOT more education on this.

- We did have to buy a very expensive tumbling composter because of rats and the overall quantity that we were composting.
- We do not compost food waste because it attracts bears.
- We do recycle and compost nondairy food scraps
- We don't do food scraps because it attracts bears and other wildlife that is not safe for people or pets and they make a mess of it that causes more work/headaches
- We have a huge issue with bears frequenting our property and composting is simply out of the question and incredible unrealistic for us.
- We have been composting for 34 years
- We have been composting for 45 years.
- We have several compost piles: One for food scraps, one for garden refuse and one for seed-bearing weeds and woody stems.
- We have two composters. One for meat and bones, and the other for all the rest.
- We live in an area with bears, raccoons, foxes, and other animals. Our neighbors who compost always have trouble with these animals destroying their property. We do not.
- We often mix our compost with horse manure, in the winter time. In the warmer months we mix it in a rotating compost barrel
- We only compost fruits, vegetables, and egg shells, and not meat, dairy, and grains. This is for the safety of our pets.
- We pay for compostable bags to go inside our rolling compost cart. The WSW district suggested the bags, as "reducing the ick factor of composting". The bags are expensive, but definitely keep things cleaner. Another household member rinses off the cart in & out in hot weather. Renters may not have access to hose, or find it hard to go up & down stairs multiple times a day. I think subsidizing the cost of carts & inner bags would increase compliance with composting.
- We stopped composting in the winter because our bin fills up and freezes
- We think it's hilarious that our HOA forbids trash containers to be visible to the street but composting bins are allowed. Kind of hypocritical.
- We use a unit called a Food Cycler. It is handy, quiet, and relatively odor-free. It creates a great compost product that we use in our garden/flower beds. More people should look into this as there is no need to worry about bears and other animals rummaging through the scraps.
- We used to compost both in and open home-built bin and a tumbler. My husband did most of the composting work. He is now 89 and unable to do that work. I choose to drop off all our compost to the CSWD.
- We've had bears destroy 2 compost tumblers
- What do citizens think about (1) what happens with composting after it leaves the depositing stations, (2) what the average cost per gallon is to deposit scraps at

depositing stations and (3) what profit or value do the stations get for processing the scraps?

- What if you are disabled? You never asked that in your survey
- What works in the city, where both the population centers and the legislators live, doesn't always work every throughout the rest of the State.
- When I go to the transfer station my nose tells me that not everyone is composting their food waste.
- When I was able to, I composted in my garden. I am not physically able to do it now. I do not have a garden anymore.
- When it comes to composting, I am not sure how to handle things like jarred sauces, mayonnaise, and 'wet' items. They tend to mold in compost. More information would help.
- When we had the 2-gallon container inside the house, we had problems with fruit flies. Using a smaller container in the house cuts down on fruit flies. We also use compostable take out containers as "brown matter" in our compost.
- When you talk about composting food scraps you should clarify what type - ex meat based or vegetable matter. If you live in a rural location there would need to be some problem solving to be able to compost meat food scraps.
- Where can I hear about survey findings?
- While our household primarily uses a garbage disposal, we would be interested in composting if there was regular compost pickup along with trash and recycling. However, this is not available (or not known to be available by our household).
- Winter composting is challenging. I store compost in 5-gallon buckets in the garage so it freezes. In spring, it goes into the composter. Kind of gross?
- Wish all states had the commitment to composting as Vermont (and Brattleboro) does!
- With respect to climate change should white paper and cardboard be composted or shipped off to be put through the wringer again?
- Within the week I started composting a bear came and attacked my chicken coop killing 8 out of 12 chickens. Never in my 8 years of having chickens have we had a bear. Also, many VT people have a dumpster from a NH company so some people ignore the law.
- Would love to know the results of your surveys.
- Yea Compost!!!!
- Yes moved to Vermont from upstate NY
- You are asking questions that are not relevant to compost. Why ask only about military service? Peace Corps; Americore, a church affiliated or other NGOs?
- Your questions are usually very well designed. However, in asking whether compost smells or attracts insects, animals the answer is dependent upon how people manage their compost. If done correctly, it won't smell or attract animals.
- Your surveys are valuable....keep it up.

Appendix C

Vermont Compost Questionnaire

CONSENT

You are invited to participate in a study of Vermont residents about food scraps and composting, sponsored by the Vermont Agency of Natural Resources. The use of human subjects in this project has been approved by the UNH Institutional Review Board (IRB) for the Protection of Human Subjects in Research.

- The questionnaire will take about 10 minutes to complete.
- Participation is completely voluntary and refusal to participate will not affect you in any way. You may refuse to answer any questions or stop at any time.
- Your answers will be combined with the answers of residents across the state and used for research purposes only.
- Data will be kept in secured files, available only to the researchers. We will make every effort to maintain the confidentiality of the data.
- Research via the internet presents minimal risk of a breach of confidentiality. You are not anticipated to receive any direct benefits from participating in this research.

By clicking the "Yes, I'd like to participate" button below, you are indicating that you consent to participate in this study. If you prefer not to participate, please simply close this window in your browser.

If you have any questions about the questionnaire, please contact Zach Azem at the University of New Hampshire Survey Center, zachary.azem@unh.edu or 603-862-4858.

If you have any questions about your rights as a research participant, you may contact Melissa McGee in UNH Research Integrity Services, melissa.mcgee@unh.edu or 603-862-2005 to discuss them.

Thank you for your participation!

Q1 In 2020, the Vermont Universal Recycling Law (Act 148) banned food scraps and other organic waste that decomposes from being disposed of in regular trash and landfills. In your opinion, how informed or uninformed are Vermonters about this change?

- Very informed (1)
- Informed (2)
- Neither informed nor uninformed (3)
- Uninformed (4)
- Very uninformed (5)

Q2 Whether or not you currently compost food scraps, we'd like to know how true each statement below is for you:

	Very True (1)	Mostly True (2)	A Little True (3)	Not At All True (4)	Don't Know (5)
Composting food scraps is too much work (1)	<input type="radio"/>	<input type="radio"/>	<input type="radio"/>	<input type="radio"/>	<input type="radio"/>
Composting food scraps is good for the environment (2)	<input type="radio"/>	<input type="radio"/>	<input type="radio"/>	<input type="radio"/>	<input type="radio"/>
Compost piles and bins attract pests like insects and vermin (3)	<input type="radio"/>	<input type="radio"/>	<input type="radio"/>	<input type="radio"/>	<input type="radio"/>
Composting food scraps is just not worth the effort (4)	<input type="radio"/>	<input type="radio"/>	<input type="radio"/>	<input type="radio"/>	<input type="radio"/>
Vermonters should compost food scraps (5)	<input type="radio"/>	<input type="radio"/>	<input type="radio"/>	<input type="radio"/>	<input type="radio"/>
I don't have the space to compost food scraps (6)	<input type="radio"/>	<input type="radio"/>	<input type="radio"/>	<input type="radio"/>	<input type="radio"/>
Composting food scraps smell bad (7)	<input type="radio"/>	<input type="radio"/>	<input type="radio"/>	<input type="radio"/>	<input type="radio"/>
Composting food scraps is easy (8)	<input type="radio"/>	<input type="radio"/>	<input type="radio"/>	<input type="radio"/>	<input type="radio"/>

Q3 INT This questionnaire hopes to learn more about how Vermonters manage food scraps at home. In your answers, do not include any information about yard or garden waste.

Q3 What does your household do with food waste that comes from eating or preparing food including any scraps, inedible parts, and spoiled or rotten foods? **(Select all that apply)**

- Put in with the regular trash (1)
 - Put down the garbage disposal (or down the sink) (2)
 - Set it aside for composting in your backyard or own compost pile (3)
 - Set it aside for composting with the compost being picked up by a waste hauler (4)
 - Set it aside for composting with the compost being dropped off at a transfer station or other collection site (5)
 - Feed it to farm animals or livestock (6)
 - Feed it to pets (7)
 - Something else: please describe: (8)
-
- Don't know (9)

Q4 Which best describes the size of the container your household uses to set aside items for composting or animal feed?

- About the size of a quart of milk (A) (1)
 - About the size of a half-gallon of milk (B) (2)
 - About the size of a gallon or milk (C) (3)
 - About the size of a 2 gallon bucket (D) (4)
 - About the size of a large 5 gallon bucket (E) (5)
 - Some other size, please describe or provide measurements: (6)
-

Q5 Thinking about last week, about how often did your household empty the container used to set items aside for composting or animal feed?

- More than once per day (1)
- Daily (2)
- Six times per week (3)
- Five times per week (4)
- Four times per week (5)
- Three times per week (6)
- Twice per week (7)
- Once per week (8)
- Less than once per week (9)
- Did not set aside items for composting or animal feed last week (10)

Skip To: Q13 If Thinking about last week, about how often did your household empty the container used to set item... = Did not set aside items for composting or animal feed last week

Q6 On average, how full was the container when it was emptied?

- Completely or almost full (1)
- About 3/4 (75%) full (2)
- About half (50%) full (3)
- About 1/4 (25%) or less full (4)

Q7INT The questions below are to estimate where all (100%) of your household's food scraps/waste set aside for composting from last week went. Please check that your responses for these below questions total 100%.

Q7PER Thinking about all of the food waste set aside for composting by your household last week, please estimate approximately what percentage was dealt with in each of the following ways:

	% of household's food scraps (1)
Thrown in the regular trash (Q7)	
Fed to farm animals or livestock (Q8)	
Fed to pets (Q9)	
Placed in your own compost pile or composter (Q10)	
Picked up by a waste hauler specifically for composting (Q11)	
Dropped off at a transfer station or other collection point specifically for composting (Q12)	
Total	

Q13 Which method(s) do you use for composting? (Select all that apply)

- I put the scraps in a unit outside that turns or rotates (1)
 - I put the scraps outside in a pile or heap (2)
 - I put the scraps in a stationary bin outside that I purchased (3)
 - I put the scraps in a stationary bin outside that I built (4)
 - Some other method, please describe: (5)
-

- I do not have my own composting method at home, my food scraps are dropped off or hauled (6)
-

Q14 About what percentage of food scraps do you typically compost at each of the following times of the year?

	% of food scraps composted (1)
Winter (1)	
Spring (2)	
Summer (3)	
Fall (4)	

TOWN_VT

We have a few final questions.

In which town or city do you live?

▼ Addison (1) ... Other (997)

Display This Question:

If We have a few final questions. In which town or city do you live? = Other

TOWN_VT_other You indicated an "other" town or city above. Which town or city is that?

OWNRENT Do you own or rent your home?

- Own home (1)
 - Rent home (2)
 - Not applicable (99)
-

Q15 Which best describes the location of your residence?

- On a farm (1)
- Open country, but not a farm (2)
- In a suburban setting (3)
- In an urban setting (4)

Q16 Which of the following comes closest to the kind of housing unit you now live in?

- Detached single-family home (1)
 - Mobile home (2)
 - Townhouse/Condominium (3)
 - Apartment/Duplex (4)
 - Other, please specify: (5)
-

Q17 Whether or not anyone in your household gardens, do you have a yard or outside space on which you can garden?

- Yes (1)
- No (2)

D1 Are you currently married, widowed, divorced, separated, or have you never been married?

- Married (1)
- Widowed (2)
- Divorced (3)
- Separated (4)
- Never married (5)
- Living together (6)

GENDER Which of the following best describes your gender?

- Woman (1)
- Man (2)
- Transgender (3)
- Gender expansive (4)
- Prefer not to say (99)

RACE Which of the following ethnic or racial groups do you identify with? (Please select all that apply)

- Native American, Inuit, or Aleut (1)
 - Asian American/Pacific Islander (2)
 - African American/Black/Caribbean American (3)
 - Caucasian/White (4)
 - Latin/Hispanic (5)
 - Other (Please specify) (97)
-

- Prefer not to say (99)

VET Are you or any person in your household a member or veteran of the armed forces?

- Yes (1)
- No (2)
- Don't know/Not sure (98)

D3 What is the highest grade in school or level of education that you've completed and got credit for?

- Eighth grade or less (1)
- Some high school (2)
- High school graduate (includes G.E.D.) (3)
- Technical school (4)
- Some college (5)
- College graduate (6)
- Postgraduate work (7)
- Don't know/Not sure (98)

EMPLOY Which of the following best describes your current employment status? Are you currently...

- Employed full-time (1)
- Employed part-time (2)
- Retired or not working (3)
- Unemployed (4)
- Student (5)

NEWS

Which of the following types of media do you regularly watch, read, or listen to?
(Please select all that apply)

- Local news (such as WCAX) (1)
 - Fox News (2)
 - MSNBC (3)
 - CNN (4)
 - Vermont Public Radio (5)
 - Conservative talk radio (6)
 - The Joe Rogan Experience* podcast (7)
 - The Boston Globe* (8)
 - The New York Times* (9)
 - The Washington Post* (10)
 - Other (Please specify) (97)
-

D8

And what is your current age?

(Please enter a number only)

MOVE1 Were you born in Vermont or somewhere else?

- Vermont (1)
- Somewhere else (2)

Display This Question:

If Were you born in Vermont or somewhere else? = Vermont

MOVE2 And have you always lived in Vermont or have you lived elsewhere at some point in your life?

- Have always lived in Vermont (1)
- Have lived elsewhere (2)

Display This Question:

If Were you born in Vermont or somewhere else? = Somewhere else

Or And have you always lived in Vermont or have you lived elsewhere at some point in your life? = Have lived elsewhere

MOVE3

What state did you move to Vermont from?

(If you have moved to Vermont more than once, please enter the state you moved from most recently)

▼ Alabama (1) ... Don't know/Not sure (98)

Display This Question:

If Were you born in Vermont or somewhere else? = Somewhere else

Or And have you always lived in Vermont or have you lived elsewhere at some point in your life? = Have lived elsewhere

MOVE4 What year did you move to Vermont?

(If you have moved to Vermont more than once, please enter the year in which you moved most recently)

D9

How many years **in total** have you lived in Vermont?

(Please enter a number only. For 1 year or less, enter 1)

D10 How many of the persons who currently live in your household are under 18 years of age, including babies and small children?

- None (0)
- One (1)
- Two (2)
- Three (3)
- Four (4)
- Five (5)
- Six (6)
- Seven or more (7)
- Don't know/Not sure (98)

Display This Question:

If How many of the persons who currently live in your household are under 18 years of age, including... = One

Or How many of the persons who currently live in your household are under 18 years of age, including... = Two

Or How many of the persons who currently live in your household are under 18 years of age, including... = Three

Or How many of the persons who currently live in your household are under 18 years of age, including... = Four

Or How many of the persons who currently live in your household are under 18 years of age, including... = Five

Or How many of the persons who currently live in your household are under 18 years of age, including... = Six

Or How many of the persons who currently live in your household are under 18 years of age, including... = Seven or more

D10B Please indicate what age groups the children in the household fall under:

	Ages (1)
5 and younger (1)	
6-12 (2)	
13-17 (3)	

D11 Including yourself, how many adults currently live in your household?

- One (1)
- Two (2)
- Three (3)
- Four (4)
- Five (5)
- Six (6)
- Seven or more (7)
- Don't know/Not sure (98)

D16 How much **total** income did you and your family receive in 2022, not just from wages or salaries but from **all** sources, that is, before taxes and other deductions were made?

- Less than \$15,000 (Less than \$1,250 per month) (1)
- \$15,000-\$29,999 (\$1,250-\$2,499 per month) (2)
- \$30,000-\$44,999 (\$2,500-\$3,749 per month) (3)
- \$45,000-\$59,999 (\$3,750-\$4,999 per month) (4)
- \$60,000-\$74,999 (\$5,000-\$6,249 per month) (5)
- \$75,000-\$99,999 (\$6,250-\$8,333 per month) (6)
- \$100,000-\$149,999 (\$8,334-\$12,499 per month) (7)
- \$150,000-\$199,999 (\$12,500-\$16,666 per month) (8)
- \$200,000 and over (\$16,667 and over per month) (9)
- Don't know/Not sure (98)
- Prefer not to say (99)

ENDCOM Thank you for participating! Before you submit your responses, do you have any final comments or feedback that you would like the researchers to know about?





11875 High Tech Avenue, Suite 150
Orlando, FL 32817
mswconsultants.com | 800.679.9220