

PA-200, PA-220, PA-500, PA-800 Series, PA-3000 Series, PA-5000 Series, PA-5200 Series and PA-7000 Series Firewalls Non-Proprietary Security Policy

Corporate Headquarters  
Palo Alto Networks  
3000 Tannery Way  
Santa Clara, CA 95054

Palo Alto Networks, Inc.

[www.paloaltonetworks.com](http://www.paloaltonetworks.com)

© 2018 Palo Alto Networks, Inc. Palo Alto Networks is a registered trademark of Palo Alto Networks. A list of our trademarks can be found at <http://www.paloaltonetworks.com/company/trademarks.html>. All other marks mentioned herein may be trademarks of their respective companies. Non-proprietary security policy may be reproduced only in its original entirety (without revision).

**Revision Date: October 1, 2018**

## Change Record

Table 1 - Change Record

Date	Author	Description of Change
10/31/17	A. Shahhosseini	Added new hardware and updated to PAN-OS 8.0.3
1/12/2018	A. Shahhosseini	Updates to address CMVP comments
2/14/2018	A. Shahhosseini	Updates to address CMVP comments
4/11/2018	A. Shahhosseini	Added firmware version 8.0.6 and 8.0.9
10/1/2018	A. Shahhosseini	Added firmware version 8.0.12 and 8.0.13

## Contents

Tables	4
Figures	4
Module Overview .....	7
Security Level .....	11
Modes of Operation .....	11
<i>FIPS Approved Mode of Operation</i> .....	11
<i>Approved and Allowed Algorithms</i> .....	12
<i>Non-Approved, Non-Allowed Algorithms</i> .....	15
Ports and Interfaces .....	16
Identification and Authentication Policy .....	29
<i>Assumption of Roles</i> .....	29
Access Control Policy .....	31
<i>Roles and Services</i> .....	31
<i>Unauthenticated Services</i> .....	32
<i>Definition of Critical Security Parameters (CSPs)</i> .....	32
<i>Definition of Public Keys</i> .....	34
<i>Definition of CSPs Modes of Access</i> .....	35
Operational Environment .....	36
Security Rules .....	36
<i>FIPS 140-2 Security Rules</i> .....	36
<i>Physical Security Mechanisms</i> .....	39
<i>Operator Required Actions</i> .....	57
Mitigation of Other Attacks Policy .....	57
Definitions and Acronyms .....	58
Reference Documents .....	59
Appendix A - PA-200 - FIPS Accessories/Tamper Seal Installation (5 Seals) .....	60
Appendix B - PA-220 - FIPS Accessories/Tamper Seal Installation (6 Seals) .....	63
Appendix C - PA-500 - FIPS Accessories/Tamper Seal Installation (12 Seals) .....	65
Appendix D - PA-800 series - FIPS Accessories/Tamper Seal Installation (11 Seals) .....	72
Appendix E - PA-3020 and PA-3050 - FIPS Accessories/Tamper Seal Installation (7 Seals) .....	75
Appendix F - PA-3060 - FIPS Accessories/Tamper Seal Installation (8 Seals) .....	78
Appendix G - PA-5000 Series - FIPS Accessories/Tamper Seal Installation (17 Seals) .....	81
Appendix H - PA-5200 - FIPS Accessories/Tamper Seal Installation (28 Seals) .....	84
Appendix I - PA-7050 - FIPS Accessories/Tamper Seal Installation (24 Seals) .....	87
Appendix J - PA-7080 - FIPS Accessories/Tamper Seal Installation (10 Seals) .....	97

## Tables

Table 1 - Change Record .....	2
Table 2 - Validated Version Information .....	9
Table 3 - Module Security Level Specification .....	11
Table 4 - FIPS Approved Algorithms Used in the Module .....	12
Table 5 - FIPS Allowed Algorithms Used in the Module .....	14
Table 6 - Supported Protocols in FIPS Approved Mode .....	14
Table 7 - Non-Approved Mode of Operation .....	15
Table 8 - PA-200 FIPS 140-2 Ports and Interfaces .....	16
Table 9 - PA-220 FIPS 140-2 Ports and Interfaces .....	17
Table 10 - PA-500 & PA-500-2GB FIPS 140-2 Ports and Interfaces .....	18
Table 11 - PA-3000 Series FIPS 140-2 Ports and Interfaces .....	20
Table 12 - PA-5000 Series FIPS 140-2 Ports and Interfaces .....	22
Table 13 - PA-5200 Series FIPS 140-2 Ports and Interfaces .....	23
Table 14 - PA-7050 FIPS 140-2 Ports and Interfaces .....	25
Table 15 - PA-7080 FIPS 140-2 Ports and Interfaces .....	27
Table 16 - Roles and Required Identification and Authentication .....	29
Table 17 - Strengths of Authentication Mechanisms .....	30
Table 18 - Authenticated Service Descriptions .....	31
Table 19 - Authenticated Services .....	31
Table 20 - Unauthenticated Services .....	32
Table 21 - CSPs .....	32
Table 22 - Public Keys .....	34
Table 23 - CSP Access Rights within Roles & Services .....	35
Table 24 - Inspection/Testing of Physical Security Mechanisms .....	57

## Figures

Figure 1 - Logical Diagram .....	10
Figure 2 - PA-200 Front Interfaces .....	16
Figure 3 - PA-200 Rear Interfaces .....	16
Figure 4 - PA-220 Front Interfaces .....	17
Figure 5 - PA-220 Rear Interfaces .....	17
Figure 6 - PA-500 & PA-500-2GB Front Interfaces .....	18
Figure 7 - PA-500 & PA-500-2GB Back Interfaces .....	18
Figure 8 - PA-820 / PA-850 Front Interfaces .....	19
Figure 9 - PA-820 Rear Interfaces .....	19
Figure 10 - PA-850 Rear Interfaces .....	19
Figure 11 - PA-3020 / PA-3050 Front Interfaces .....	20
Figure 12 - PA-3020 / PA-3050 Back Interfaces .....	20
Figure 13 - PA-3060 Front Interfaces .....	20

Figure 14 - PA-3060 Back Interfaces .....	20
Figure 15 - PA-5020 Front Interfaces .....	21
Figure 16 - PA-5050/PA-5060 Front Interfaces .....	21
Figure 17 - PA-5000 Series Back Interfaces.....	21
Figure 18 - PA-5200 Series Front Interfaces .....	23
Figure 19 - PA-5200 Rear Interfaces .....	23
Figure 20 - PA-7050 Ports and Interface View .....	25
Figure 21 - PA-7080 Interfaces.....	27
Figure 22 - PA-200 Left Side and Top Tamper Seal Placement (3).....	39
Figure 23 - PA-200 Right Side Tamper Seal Placement (2) .....	39
Figure 24 - PA-220 Front with enclosure .....	40
Figure 25 – PA-220 Right Side and Front Tamper Seal Placement (3) .....	40
Figure 26 – PA-220 Left Side and Front Tamper Seal Placement (3) .....	40
Figure 27 - PA-500 with Front Opacity Shield .....	41
Figure 28 - PA-500 Front Tamper Seal Placement (1).....	41
Figure 29 - PA-500 Left Side Tamper Seal Placement (3).....	41
Figure 30 - PA-500 Right Side Tamper Seal Placement (2) .....	42
Figure 31 - PA-500 Rear Tamper Seal Placement (6) .....	42
Figure 32 - PA-800 Series Front Tamper Seal Placement with Opacity Shield (2) .....	43
Figure 33 - PA-800 Series Left Side Front Tamper Seal Placement (2) .....	43
Figure 34 – PA-800 Left Side Rear Tamper Seal Placement (1) .....	44
Figure 35 –PA-800 Right Side Rear Tamper Seal Placement (3) .....	44
Figure 36 - Rear Tamper Seal Placement (3).....	45
Figure 37 - PA-3020 / PA-3050 side with Opacity Shield .....	46
Figure 38 - PA-3020/PA-3050 Series Tamper Seal Placement (3).....	46
Figure 39 - PA-3020/PA-3050 Series Tamper Seal Placement (2).....	47
Figure 40 - PA-3020/PA-3050 Series Tamper Seal Placement (2).....	47
Figure 41 – PA-3060 Right side .....	47
Figure 42 – PA-3060 Left side .....	47
Figure 43 – PA-3060 Front/Top Tamper Seal Placement.....	48
Figure 44 – PA-3060 Front/Bottom Tamper Seal Placement.....	48
Figure 45 - PA-5000 Series Rear Tamper Seal Placement (9) with opacity shields.....	48
Figure 46 - PA-5000 Series Right Side Tamper Seal Placement (4).....	49
Figure 47 - PA-5000 Series Left Side Tamper Seal Placement (4) .....	49
Figure 48 - PA-5200 Series front Opacity Shield .....	50
Figure 49 - PA-5200 Series Left Side with Front Opacity Shield.....	50
Figure 50 - PA-5200 Series Right Side with Front Opacity Shield .....	51
Figure 51 - PA-5200 Series Rear Opacity Shield .....	51
Figure 52 - PA-7050 Front View with Opacity Shields.....	52
Figure 53 - PA-7050 Rear View with Opacity Shields.....	52
Figure 54 - PA-7050 Front and Right Side with Opacity Shields .....	52

Figure 55 - PA-7050 Rear and Left Side with Opacity Shields ..... 52

Figure 56 - PA-7050 Tamper Seal Placement for Top Plenum (1-4) ..... 53

Figure 57 - PA-7050 Tamper Seal Placement for Bottom Plenum (5-6) ..... 53

Figure 58 - PA-7050 Tamper Seal Placement for Rear (7-20) ..... 54

Figure 59 - PA-7050 Tamper Seal Placement for Top Plenum Bracket (21-22) ..... 54

Figure 60 - PA-7050 Tamper Seal Placement for Bottom Plenum Bracket (23-24) ..... 55

Figure 61 - PA-7080 Front with Opacity Shield ..... 56

Figure 62 - PA-7080 Rear ..... 56

Figure 63 - PA-7080 Tamper Seal Placement on Left Side for Front Opacity Shield (1) ..... 57

Figure 64 - PA-7080 Tamper Seal Placement on Right Side for Front Opacity Shield (1) ..... 57

## Module Overview

Palo Alto Networks offers a full line of next-generation security appliances that range from the PA-200, designed for enterprise remote offices, to the PA-7080, which is a modular chassis designed for high-speed datacenters. Our platform architecture is based on our single-pass software engine, PAN-OS, for networking, security, threat prevention, and management functionality that is consistent across all platforms. The devices differ only in capacities, performance, and physical configuration.

The Palo Alto Networks PA-200, PA-220, PA-500, PA-800 Series, PA-3000 Series, PA-5000 Series, PA-5200 Series, and PA-7000 Series Firewalls (hereafter referred to as the modules) are multi-chip standalone modules that provide network security by enabling enterprises to see and control applications, users, and content – not just ports, IP addresses, and packets – using three unique identification technologies: App-ID, User-ID, and Content-ID. These identification technologies, found in Palo Alto Networks' enterprise firewalls, enable enterprises to create business-relevant security policies – safely enabling organizations to adopt new applications, instead of the traditional “all-or-nothing” approach offered by traditional port-blocking firewalls used in many security infrastructures.

### Features and Benefits

- **Application visibility and control:** Accurate identification of the applications traversing the network enables policy-based control over application usage at the firewall, the strategic center of the security infrastructure.
- **Visualization tools:** Graphical visibility tools, customizable reporting and logging enables administrators to make a more informed decision on how to treat the applications traversing the network.
- **Application browser:** Helps administrators quickly research what the application is, its' behavioral characteristics and underlying technology resulting in a more informed decision making process on how to treat the application.
- **User-based visibility and control:** Seamless integration with enterprise directory services (Active Directory, LDAP, eDirectory) facilitates application visibility and policy creation based on user and group information, not just IP address. In Citrix and terminal services environments, the identity of users sitting behind Citrix or terminal services can be used to enable policy-based visibility and control over applications, users and content. An XML API enables integration with other, 3rd party user repositories.
- **Real-time threat prevention:** Detects and blocks application vulnerabilities, viruses, spyware, and worms; controls web activity; all in real-time, dramatically improving performance and accuracy.

- **File and data filtering:** Taking full advantage of the in-depth application inspection being performed by App-ID, administrators can implement several different types of policies that reduce the risk associated with unauthorized file and data transfer.
- **Legacy firewall support:** Support for traditional inbound and outbound port-based firewall rules mixed with application-based rules smooth the transition to a Palo Alto Networks next generation firewall.
- **Networking architecture:** Support for dynamic routing (OSPF, RIP, BGP), virtual wire mode and layer 2/layer 3 modes facilitates deployment in nearly any networking environment.
- **Policy-based Forwarding:** Forward traffic based on policy defined by application, source zone/interface, source/destination address, source user/group, and service.
- **Virtual Systems:** Create multiple virtual “firewalls” within a single device as a means of supporting specific departments or customers. Each virtual system can include dedicated administrative accounts, interfaces, networking configuration, security zones, and policies for the associated network traffic.
- **VPN connectivity:** Secure site-to-site connectivity is enabled through standards-based IPSec VPN support while remote user access is delivered via SSL VPN connectivity.
- **Quality of Service (QoS):** Deploy traffic shaping policies (guaranteed, maximum and priority) to enable positive policy controls over bandwidth intensive, non-work related applications such as streaming media while preserving the performance of business applications.
- **Real-time bandwidth monitor:** View real-time bandwidth and session consumption for applications and users within a selected QoS class.
- **Purpose-built platform:** combines single pass software with parallel processing hardware to deliver the multi-Gbps performance necessary to protect today’s high speed networks.



The configurations for this validation are:

**Table 2 - Validated Version Information**

Module	Part Number	Hardware Version	FIPS Kit Part Number	FIPS Kit Hardware Version	FW
PA-200	910-000015	Rev. E	920-000084	Rev. A	8.0.3, 8.0.6, 8.0.9, 8.0.12, or 8.0.13
PA-220	910-000128	Rev. A	920-000184	Rev. A	
PA-500	910-000006	Rev. O	920-000005	Rev. A	
PA-500-2GB	910-000094	Rev. O	920-000005	Rev. A	
PA-820	910-000120	Rev. A	920-000185	Rev. A	
PA-850	910-000119	Rev. A	920-000185	Rev. A	
PA-3020	910-000017	Rev. J	920-000081	Rev. A	
PA-3050	910-000016	Rev. J	920-000081	Rev. A	
PA-3060	910-000104	Rev. C	920-000138	Rev. A	
PA-5020	910-000010	Rev. F	920-000037	Rev. A	
PA-5050	910-000009	Rev. F	920-000037	Rev. A	
PA-5060	910-000008	Rev. F	920-000037	Rev. A	
PA-5220	910-000132	Rev. A	920-000186	Rev. A	
PA-5250	910-000131	Rev. A	920-000186	Rev. A	
PA-5260	910-000125	Rev. A	920-000186	Rev. A	
PA-7050 *	910-000102	Rev. B	920-000112	Rev. A	
PA-7080 *	910-000122	Rev. A	920-000119	Rev. A	
<p>* Palo Alto Networks PA-7000 Series firewalls are tested with four different Network Processing Cards (NPC), and any NPC may be configured for use in the Approved mode of operation.</p> <ul style="list-style-type: none"> <li>• 910-000028-00B: PAN-PA-7000-20G-NPC</li> <li>• 910-000117-00A: PAN-PA-7000-20GQ-NPC</li> <li>• 910-000137-00A: PAN-PA-7000-20GXM-NPC</li> <li>• 910-000136-00A: PAN-PA-7000-20GQXM-NPC</li> </ul>					

Figure 1 depicts the logical block diagram for the modules. The cryptographic boundary includes all of the logical components of the modules and the boundary is the physical enclosure of the firewall.

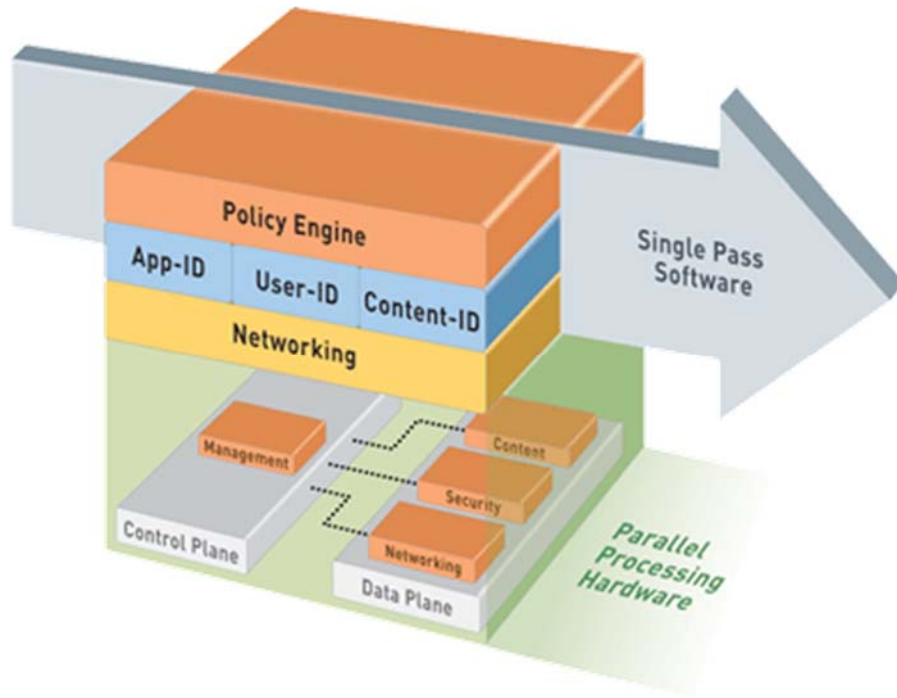

Figure 1 - Logical Diagram

## Security Level

The cryptographic modules meet the overall requirements applicable to Level 2 security of FIPS 140-2.

**Table 3 - Module Security Level Specification**

Security Requirements Section	Level
Cryptographic Module Specification	2
Module Ports and Interfaces	2
Roles, Services and Authentication	3
Finite State Model	2
Physical Security	2
Operational Environment	N/A
Cryptographic Key Management	2
EMI/EMC	2
Self-Tests	2
Design Assurance	3
Mitigation of Other Attacks	N/A

## Modes of Operation

### *FIPS Approved Mode of Operation*

The modules support both a FIPS-CC mode (FIPS Approved mode) and a Non-Approved mode. The following procedure will put the modules into the FIPS-approved mode of operation:

- Install FIPS kit opacity shields and tamper evidence seals according to the Physical Security Policy section. FIPS kits must be correctly installed to operate in the Approved mode of operation. The tamper evidence seals and opacity shields shall be installed for the module to operate in a FIPS Approved mode of operation.
- During initial boot up, break the boot sequence via the console port connection (by pressing the maint button when instructed to do so) to access the main menu.
- Select “Continue.”
- Select the “Set FIPS-CC Mode” option to enter CC mode.
- Select “Enable FIPS-CC Mode”.
- When prompted, select “Reboot” and the module will re-initialize and continue into CC mode (FIPS mode).
- The module will reboot.

- In FIPS-CC mode, the console port is available as a status output port.
- If using RADIUS or TACACS+, configure the service route via an IPsec tunnel, and ensure the RADIUS or TACACS+ server is configured for a minimum password length of 6 characters (to match Table 17 of this document), or greater. Otherwise, skip this step.

The module will automatically indicate the FIPS Approved mode of operation in the following manner:

- Status output interface will indicate “\*\*\*\*\* FIPS-CC MODE ENABLED \*\*\*\*\*” via the CLI session.
- Status output interface will indicate “FIPS-CC mode enabled successfully” via the console port.
- The module will display “FIPS-CC” at all times in the status bar at the bottom of the web interface.

Should one or more power-up self-tests fail, the FIPS Approved mode of operation will not be achieved. Feedback will consist of:

- The module will output “FIPS-CC failure”
- The module will reboot and enter a state in which the reason for the reboot can be determined.
- To determine which self-test caused the system to reboot into the error state, connect the console cable and follow the on-screen instructions to view the self-test output.

### **Approved and Allowed Algorithms**

The cryptographic modules support the following FIPS Approved algorithms in the Approved mode.

**Table 4 - FIPS Approved Algorithms Used in the Module**

<b>FIPS Approved Algorithm</b>	<b>CAVP Cert. #</b>
AES [FIPS 197, SP800-38A]: - ECB, CBC, CFB, CTR modes; Encrypt/Decrypt; 128, 192 and 256-bit (AES OFB, CFB 192 and CFB 256 were tested but are not available for use)	4532
AES-CCM [SP800-38C]: Encrypt and Decrypt, 128-bit	4532
AES-GCM [SP800-38D]: Encrypt and Decrypt, 128 and 256-bit (192 bit was tested but not available for use) Note: GCM IV handling is compliant with FIPS IG A.5 and SP800-38D.*	4532
CKG (SP800-133) Key Generation Vendor Affirmed - Asymmetric per Section 6 - Symmetric per Section 7	N/A
CVL: Elliptic Curve Diffie-Hellman Exchange [SP800-56A] - ECC CDH primitive (§5.7.1.2) - KAS-ECC all except KDF	CVL 1211
CVL: Diffie-Hellman Exchange [SP800-56A] - KAS-FFC all except KDF	CVL 1211

FIPS Approved Algorithm	CAVP Cert. #
CVL: KDF, Application Specific [SP800-135] - TLS 1.0/1.1/1.2 KDF - SNMPv3 KDF - SSHv2 KDF - IKE v1/v2 KDF	CVL 1212
CVL: RSA [SP800-56B] - RSADP	CVL 1213
DRBG [SP800-90A]: CTR DRBG with AES-256	1489
DSA [FIPS 186-4]: Key Generation (as prerequisite to CVL #1211)	1207
ECDSA [FIPS 186-4] - Key Pair Generation P-256, P-384, and P-521 - PKV P-256, P-384, and P-521 - Signature Generation P-256, P-384 and P-521; with all SHA-2 sizes* - Signature Verification P-256, P-384 and P-521; with SHA-1 and all SHA-2 sizes* *Does not include the "short SHA-512" sizes SHA-512/224 or SHA-512/256	1103
HMAC [FIPS 198] - HMAC-SHA-1 with $\lambda=96, 160$ - HMAC-SHA-256 with $\lambda=256$ - HMAC-SHA-384 with $\lambda=384$ - HMAC-SHA-512 with $\lambda=512$	2990
KAS: SP 800-56A Rev.2 Elliptic Curve Diffie-Hellman Exchange (CVL Certs. #1211 and #1212, vendor affirmed; key agreement; key establishment methodology provides between 128 and 256 bits of encryption strength)	N/A
KAS: SP 800-56A Rev.2 Diffie-Hellman Exchange (CVL Certs. #1211 and #1212, vendor affirmed; key agreement; key establishment methodology provides 112 bits of encryption strength)	N/A
KTS [SP800-38F §3.1]: Option 1: AES-CBC (128 or 256 bit) plus HMAC Option 2: AES-GCM (128 or 256 bit) (Key wrapping; for both listed options, key establishment methodology provides between 128 and 256 bits of encryption strength)	AES 4532 HMAC 2990
RSA [FIPS 186-4]: - Key Generation: 2048 and 3072-bit - Signature Generation: 2048 and 3072-bit - Signature Verification: 1024, 2048 and 3072-bit - Padding Schemes: ANS X9.31, PKCS #1 v1.5, PSS - Hashes: SHA-1, SHA-224, SHA-256, SHA-384, SHA-512 (Refer to RSA Cert. #2464 for the exact keysize/padding/hash combinations in use.)	2467

FIPS Approved Algorithm	CAVP Cert. #
SHA-1 and SHA-2 [FIPS 180-4]: - Hashes: SHA-1, SHA-224, SHA-256, SHA-384, SHA-512 - Usage: Digital Signature Generation & Verification, Non-Digital Signature Applications (e.g., component of DRBG and HMAC)	3713

\* The module is compliant to IG A.5: GCM is used in the context of TLS, IPsec/IKEv2, SSH, and IPsec/IKEv1:

- For TLS, The GCM implementation meets Option 1 of IG A.5: it is used in a manner compliant with SP 800-52 and in accordance with Section 4 of RFC 5288 for TLS key establishment. (From this RFC, the GCM cipher suites in use are TLS\_RSA\_WITH\_AES\_128\_GCM\_SHA256, TLS\_RSA\_WITH\_AES\_256\_GCM\_SHA384, TLS\_ECDHE\_ECDSA\_WITH\_AES\_128\_GCM\_SHA256, TLS\_ECDHE\_ECDSA\_WITH\_AES\_256\_GCM\_SHA384, TLS\_ECDHE\_RSA\_WITH\_AES\_128\_GCM\_SHA256, and TLS\_ECDHE\_RSA\_WITH\_AES\_256\_GCM\_SHA384.) During operational testing, the module was tested against an independent version of TLS and found to behave correctly.
- For IPsec/IKEv2, The GCM implementation meets Option 1 of IG A.5: it is used in a manner compliant with RFCs 4106 and 7296 (RFC 5282 is not applicable, as the module does not use GCM within IKEv2 itself). During operational testing, the module was tested against an independent version of IPsec with IKEv2 and found to behave correctly.
- For SSH, the module meets Option 4 of IG A.5. The fixed field is 32 bits in length and is derived using the SSH KDF; this ensures the fixed field is unique for any given GCM session. The invocation field is 64 bits in length and is incremented for each invocation of GCM; this prevents the IV from repeating until the entire invocation field space of  $2^{64}$  is exhausted. (It would take hundreds of years for this to occur.)
- For IPsec/IKEv1, the module meets Option 4 of IG A.5. The behavior is the same as the above description for SSH, except the fixed field is derived using the IKEv1 KDF instead of the SSH KDF.

In all of the above cases, the nonce\_explicit is always generated deterministically.

The cryptographic modules support the following non-FIPS Approved algorithms that are allowed for use in FIPS-CC mode.

**Table 5 - FIPS Allowed Algorithms Used in the Module**

FIPS Allowed Algorithm
Diffie-Hellman, non-compliant to SP800-56A [safe primes: L=2048, N=2047] (key agreement; key establishment methodology provides 112 bits of encryption strength)
MD5 (within TLS)
NDRNG (used to seed SP800-90A DRBG) This provides a minimum of 256 bits of entropy.
RSA unwrap, non-compliant to SP800-56B (key wrapping, key establishment methodology provides 112 or 128 bits of encryption strength)

**Table 6 - Supported Protocols in FIPS Approved Mode**

Supported Protocols*
TLSv1.0, 1.1 and v1.2
SSHv2
IPSec, IKEv1 and v2
SNMPv3

\*Note: these protocols were not reviewed or tested by the CMVP or CAVP.

### ***Non-Approved, Non-Allowed Algorithms***

The cryptographic modules support the following non-Approved algorithms. No security claim is made in the current modules for any of the following non-Approved algorithms. All algorithms in this mode of operation are deemed as non-compliant.

**Table 7 - Non-Approved Mode of Operation**

<b>Non-Approved Algorithms in Non-FIPS mode</b>
Hashing: RIPEMD, MD5
Encrypt/Decrypt: Camellia, SEED, Triple-DES(non-compliant), Blowfish, CAST, RC4, DES
Message Authentication: UMAC, HMAC-MD5, HMAC-RIPEMD
Digital Signatures (non-Approved strengths, non-compliant): RSA Key Generation: 512, 1024 RSA signature generation: Modulus bit length less than 2048 or greater than 3072 bits; up to 16384 bits RSA signature verification: Modulus bit length less than 1024 or greater than 3072 bits; up to 16384 bits ECDSA: B, K, P curves not equal to P-256, P-384 or P-521 DSA: 768 to 4096 bits
Key Exchange (non-Approved strengths): Elliptic Curve Diffie-Hellman: B, K, P curves not equal to P-256, P-384 or P-521 Diffie-Hellman: 768, 1024 and 1536 bit modulus RSA: Less than 2048 bit modulus

## Ports and Interfaces

The modules are multi-chip standalone modules with ports and interfaces as shown below.

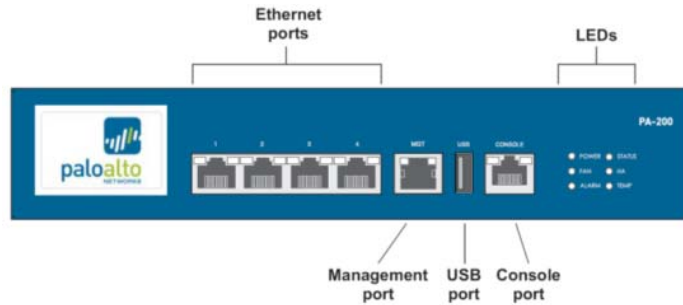

Figure 2 - PA-200 Front Interfaces



Figure 3 - PA-200 Rear Interfaces

Table 8 - PA-200 FIPS 140-2 Ports and Interfaces

Interface	Qty	FIPS 140-2 Designation	Name and Description
RJ45	1	Data input, control input, data output, status output	Console port
RJ45	1	Data input, control input, data output, status output	Out of band management
RJ45	4	Data input, control input, data output, status output	10/100/1000 Ethernet interface
DC-12V	1	Power input	Power interface
LEDs	6	Status output	Status indicators
USB	1	Disabled except for power	Used in manufacturing



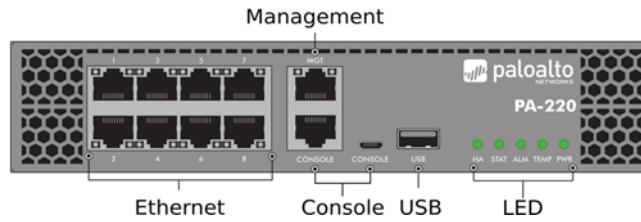

Figure 4 - PA-220 Front Interfaces

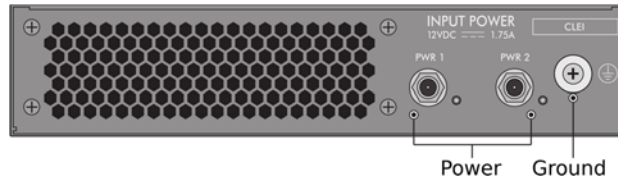

Figure 5 - PA-220 Rear Interfaces

Table 9 - PA-220 FIPS 140-2 Ports and Interfaces

Interface	Qty	FIPS 140-2 Designation	Name and Description
RJ45	1	Data input, control input, data output, status output	Console port
Micro-USB	1	Data input, control input, data output, status output	Console port
RJ45	1	Data input, control input, data output, status output	Out of band management
RJ45	8	Data input, control input, data output, status output	10/100/1000 Ethernet interface
DC-12V	2	Power input	Power interface
LEDs	5	Status output	Status indicators
USB	1	Disabled except for power	Disabled except for power

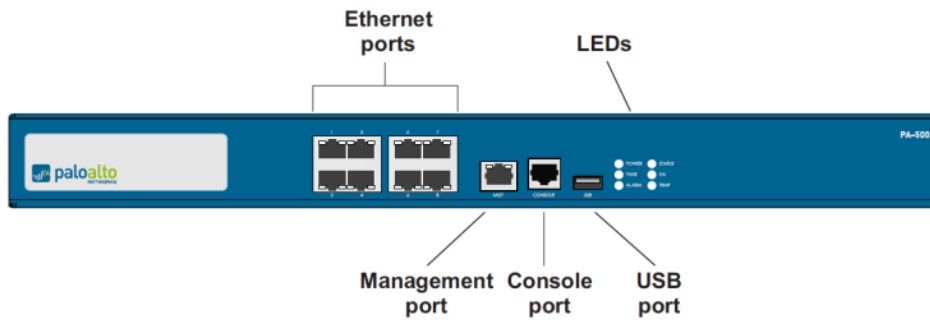

Figure 6 - PA-500 & PA-500-2GB Front Interfaces

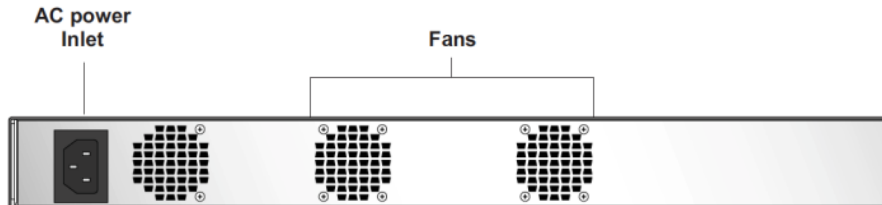

Figure 7 - PA-500 & PA-500-2GB Back Interfaces

Table 10 - PA-500 & PA-500-2GB FIPS 140-2 Ports and Interfaces

Interface	Qty	FIPS 140-2 Designation	Name and Description
RJ45	1	Data input, control input, data output, status output	Console port
RJ45	1	Data input, control input, data output, status output	Out of band management
RJ45	8	Data input, control input, data output, status output	10/100/1000 Ethernet interface
100-240 V	1	Power input	Power interface
LEDs	6	Status output	Status indicators
USB	1	Disabled except for power	Used in manufacturing

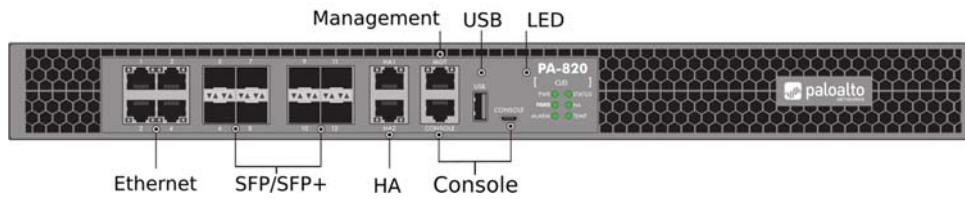

Figure 8 - PA-820 / PA-850 Front Interfaces

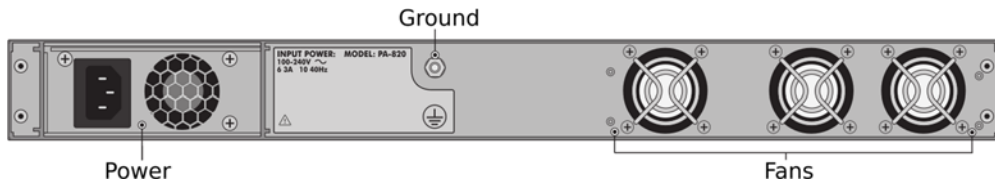

Figure 9 - PA-820 Rear Interfaces

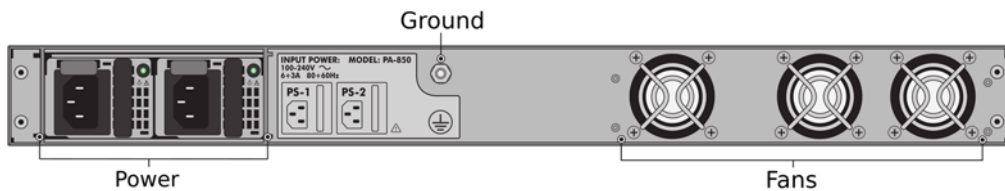

Figure 10 - PA-850 Rear Interfaces

Interface	PA-820 Qty	PA-850 Qty	FIPS 140-2 Designation	Name and Description
RJ45	1	1	Data input, control input, data output, status output	Console port
Micro-USB	1	1	Data input, control input, data output, status output	Console port
RJ45	1	1	Data input, control input, data output, status output	Out of band management
RJ45	2	2	Data input, control input, data output, status output	10/100/1000 HA Ethernet interface
RJ45	4	4	Data input, control input, data output, status output	10/100/1000 Ethernet interface
SFP	8	4	Data input, control input, data output, status output	Gigabit Ethernet interface
SFP/SFP+	N/A	4	Data input, control input, data output, status output	Gigabit or 10 Gigabit Ethernet interface
100-240 V	1	2	Power input	Power interface
LEDs	6	6	Status output	Status indicators
USB	1	1	Disabled except for power	Disabled except for power

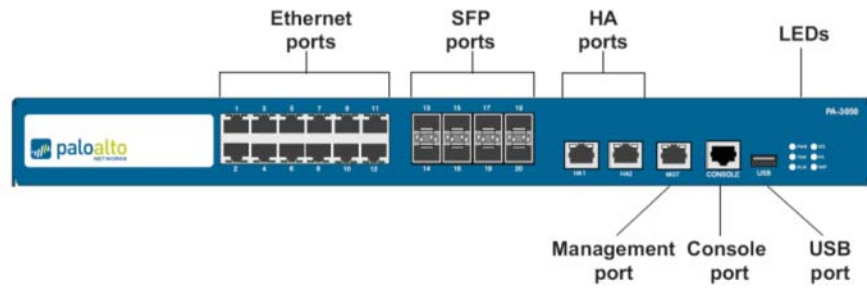

Figure 11 - PA-3020 / PA-3050 Front Interfaces



Figure 12 - PA-3020 / PA-3050 Back Interfaces

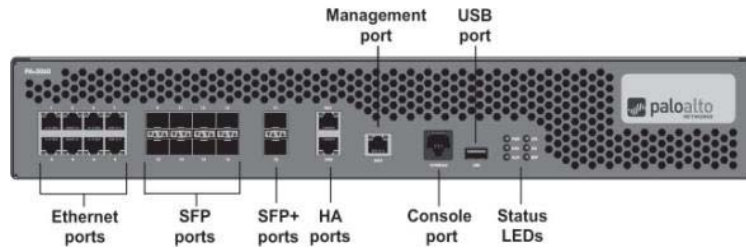

Figure 13 - PA-3060 Front Interfaces

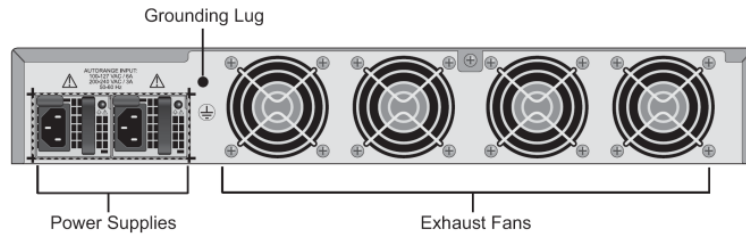

Figure 14 - PA-3060 Back Interfaces

Table 11 - PA-3000 Series FIPS 140-2 Ports and Interfaces

Interface	PA-3050 Qty	PA-3020 Qty	PA-3060 Qty	FIPS 140-2 Designation	Name and Description
RJ45	1	1	1	Data input, control input, data output, status output	Console port
RJ45	1	1	1	Data input, control input, data output, status output	Out of band management
RJ45	2	2	2	Data input, control input, data output, status output	10/100/1000 HA Ethernet interface

Interface	PA-3050 Qty	PA-3020 Qty	PA-3060 Qty	FIPS 140-2 Designation	Name and Description
SFP+	N/A	N/A	2	Data input, control input, data output, status output	Ethernet 10-gigabit interface
SFP	8	8	8	Data input, control input, data output, status output	Ethernet gigabit interface
RJ45	12	12	8	Data input, control input, data output, status output	10/100/1000 Ethernet interface
100-240 V	1	1	2	Power input	Power interface
LEDs	6	6	6	Status output	Status indicators
USB	1	1	1	Disabled except for power	Future Use

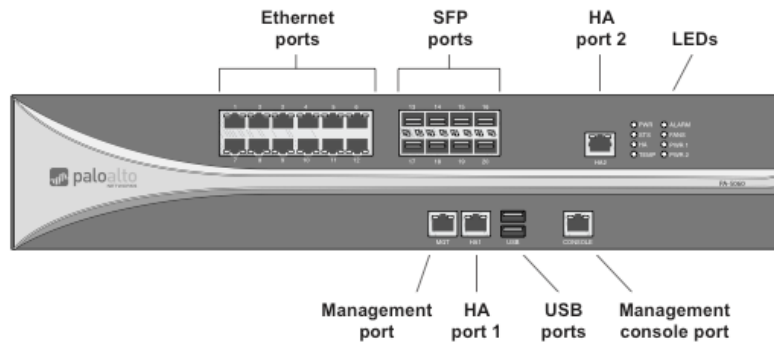

Figure 15 - PA-5020 Front Interfaces

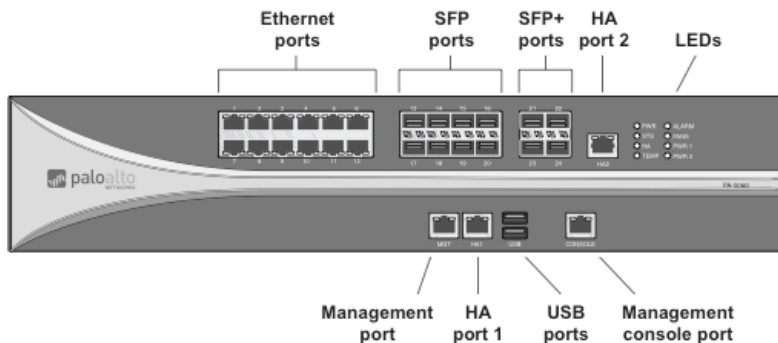

Figure 16 - PA-5050/PA-5060 Front Interfaces

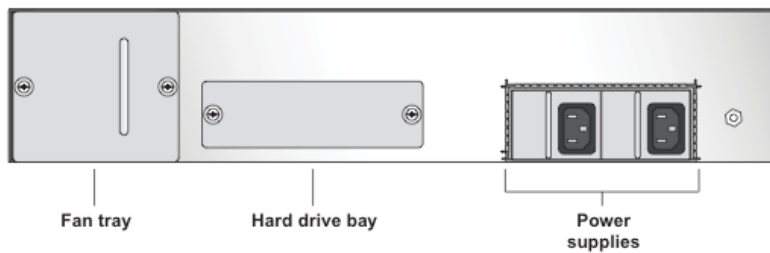

Figure 17 - PA-5000 Series Back Interfaces

Table 12 - PA-5000 Series FIPS 140-2 Ports and Interfaces

Interface	PA-5020 Qty	PA-5050 Qty	PA-5060 Qty	FIPS 140-2 Designation	Name and Description
RJ45	1	1	1	Data input, control input, data output, status output	Console port
RJ45	1	1	1	Data input, control input, data output, status output	Out of band management
SFP+	N/A	4	4	Data input, control input, data output, status output	Ethernet 10-gigabit interface
SFP	8	8	8	Data input, control input, data output, status output	Ethernet gigabit interfaces
RJ45	2	2	2	Data input, control input, data output, status output	10/100/1000 HA Ethernet interface
RJ45	12	12	12	Data input, control input, data output, status output	10/100/1000 Ethernet Interfaces
100-240 V	2	2	2	Power input	Power interface
LEDs	8	8	8	Status output	Status indicators
USB	2	2	2	Disabled except for power	Disabled except for power

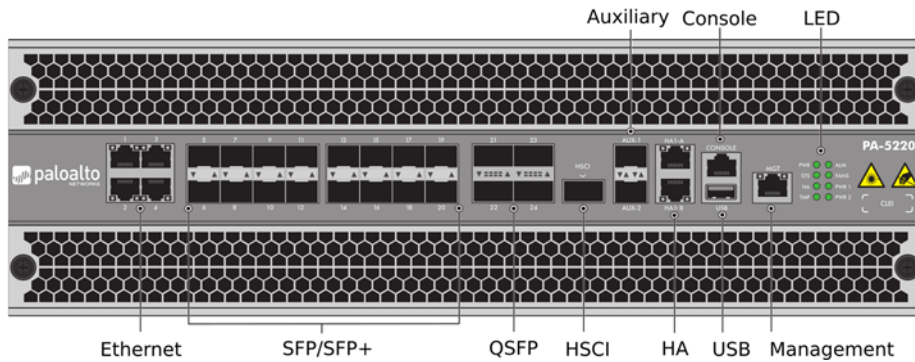

Figure 18 - PA-5200 Series Front Interfaces

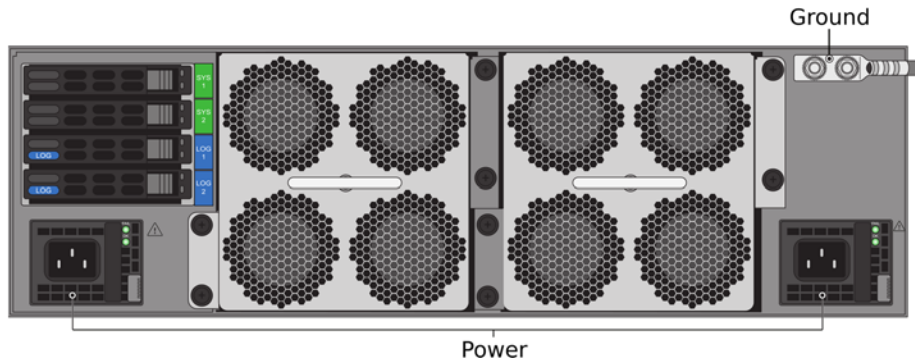

Figure 19 - PA-5200 Rear Interfaces

Table 13 - PA-5200 Series FIPS 140-2 Ports and Interfaces

Interface	PA-5220 Qty	PA-5250 Qty	PA-5260 Qty	FIPS 140-2 Designation	Name and Description
RJ45	1	1	1	Data input, control input, data output, status output	Console port
RJ45	1	1	1	Data input, control input, data output, status output	Out of band management
RJ45	2	2	2	Data input, control input, data output, status output	10/100/1000 HA Ethernet interface
RJ45	4	4	4	Data input, control input, data output, status output	10/100/1000 Ethernet Interfaces
SFP/SFP+	16	16	16	Data input, control input, data output, status output	Gigabit or 10 Gigabit Ethernet interface
QSFP28	N/A	4	4	Data input, control input, data output, status output	40/100 Gigabit defined by the IEEE 802.3ba
QSFP+	4	N/A	N/A	Data input, control input, data output, status output	40 Gigabit interfaces defined by the IEEE 802.3ba
HSCI	1	1	1	Data input, control input, data output, status output	QSFP HA interface

Interface	PA-5220 Qty	PA-5250 Qty	PA-5260 Qty	FIPS 140-2 Designation	Name and Description
SFP+	2	2	2	Data input, control input, data output, status output	Auxiliary SFP+ HA/Management Port
100-240 V	2	2	2	Power input	Power interface
LEDs	8	8	8	Status output	Status indicators
USB	1	1	1	Disabled except for power	Disabled except for power



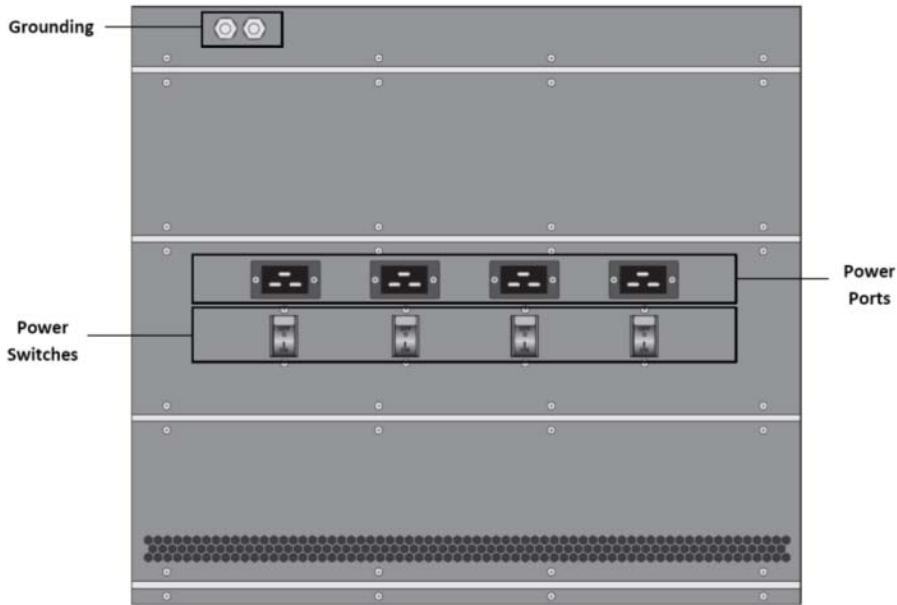
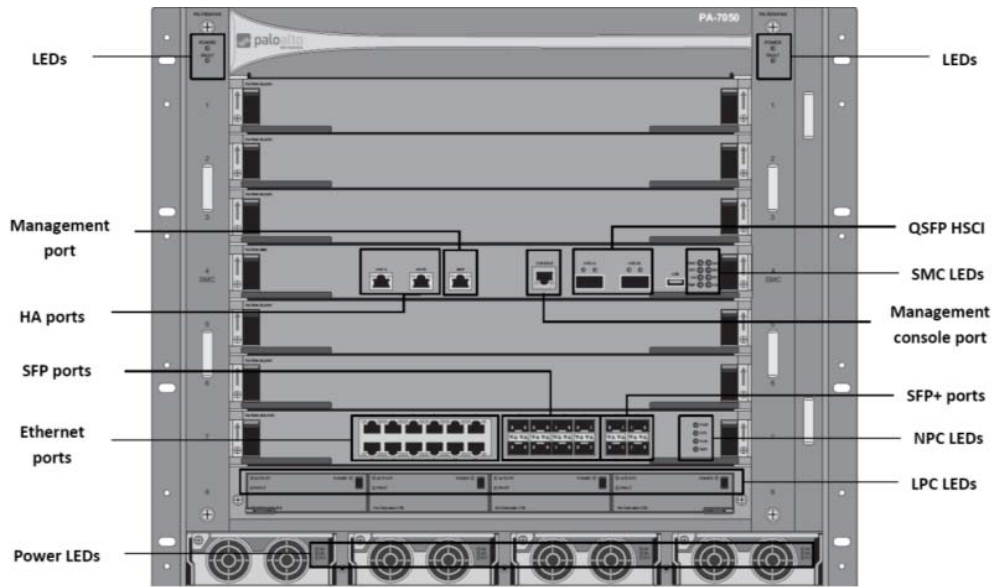

Figure 20 - PA-7050 Ports and Interface View

Table 14 - PA-7050 FIPS 140-2 Ports and Interfaces

Interface	Chassis <sup>(a)</sup> Qty	20G or 20GXM NPC <sup>(b)</sup> Qty	20GQ or 20GQXM NPC <sup>(b)</sup> Qty	FIPS 140-2 Designation	Name and Description
RJ45	1	N/A	N/A	Data input, control input, data output, status output	Console port

Interface	Chassis <sup>(a)</sup> Qty	20G or 20GXM NPC <sup>(b)</sup> Qty	20GQ or 20GQXM NPC <sup>(b)</sup> Qty	FIPS 140-2 Designation	Name and Description
RJ45	1	N/A	N/A	Data input, control input, data output, status output	Out of band management
RJ45	N/A	12	N/A	Data input, control input, data output, status output	10/100/1000 Ethernet Interfaces
SFP	N/A	8	N/A	Data input, control input, data output, status output	Ethernet gigabit interfaces
SFP+	N/A	4	12	Data input, control input, data output, status output	Ethernet 10-gigabit interface
RJ45	2	N/A	N/A	Data input, control input, data output, status output	10/100/1000 HA Ethernet interface
HSCI	2	N/A	N/A	Data input, control input, data output, status output	QSFP HA interface
QSFP+	N/A	N/A	2	Data input, control input, data output, status output	40 Gigabit interfaces defined by the IEEE 802.3ba interface
100-240 V	4	N/A	N/A	Power input	Power interface
LEDs	48 <sup>(d)</sup>	52 <sup>(c)</sup>	32 <sup>(c)</sup>	Status output	Status indicators
USB	1	N/A	N/A	Disabled except for power	Used in manufacturing
<p>a. The PA-7050 chassis includes two cards that are installed in the front slots of the chassis. These cards include the following: The Switch Management Card (SMC) provides management connectivity to the chassis and the Log Processing Card (LPC) handles all log processing and log storage for the firewall.</p> <p>b. NPC (Network Processing Card) - The PA-7050 may contain up to six (6) NPC cards. At least one (1) Network Processing Card (NPC) must be installed before the firewall can process data traffic. The PA-7000-20GXM-NPC and PA-7000-20GQXM-NPC doubles the memory of the PA-7000-20G-NPC and PA-7000-20GQ-NPC respectively, enabling support for eight million sessions (up from four million).</p> <p>c. NPC - With the four (4) standard status LED, each networking interface contains two (2) LED, the link status and activity LED.</p> <p>d. PA-7050 - Status LED count (48) includes the following: 4 for fan status, 12 for the LPC and 20 for the SMC, 12 for power supplies.</p>					

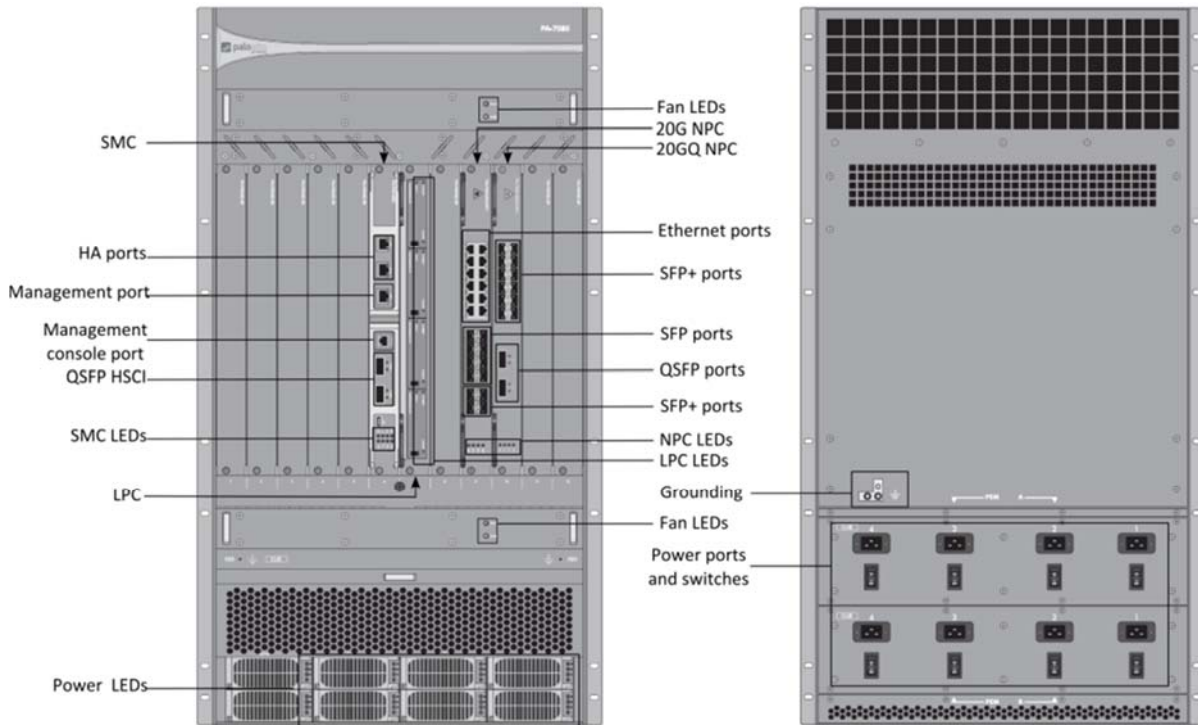

Figure 21 - PA-7080 Interfaces

Table 15 - PA-7080 FIPS 140-2 Ports and Interfaces

Interface	Chassis <sup>(a)</sup> Qty	20G or 20GXM NPC <sup>(b)</sup> Qty	20GQ or 20GQXM NPC <sup>(b)</sup> Qty	FIPS 140-2 Designation	Name and Description
RJ45	1	N/A	N/A	Data input, control input, data output, status output	Console port
RJ45	1	N/A	N/A	Data input, control input, data output, status output	Out of band management
RJ45	N/A	12	N/A	Data input, control input, data output, status output	10/100/1000 Ethernet Interfaces
SFP	N/A	8	N/A	Data input, control input, data output, status output	Ethernet gigabit interfaces
SFP+	N/A	4	12	Data input, control input, data output, status output	Ethernet 10-gigabit interface
RJ45	2	N/A	N/A	Data input, control input, data output, status output	10/100/1000 HA Ethernet interface
HSCI	2	N/A	N/A	Data input, control input, data output, status output	QSFP HA interface

Interface	Chassis <sup>(a)</sup> Qty	20G or 20GXM NPC <sup>(b)</sup> Qty	20GQ or 20GQXM NPC <sup>(b)</sup> Qty	FIPS 140-2 Designation	Name and Description
QSFP+	N/A	N/A	2	Data input, control input, data output, status output	40 Gigabit interfaces defined by the IEEE 802.3ba interface
100-240 V	4	N/A	N/A	Power input	Power interface
LEDs	52 <sup>(d)</sup>	52 <sup>(c)</sup>	32 <sup>(c)</sup>	Status output	Status indicators
USB	1	N/A	N/A	Disabled except for power	Used in manufacturing

- a. The PA-7000 series chassis includes two cards that are installed in the front slots of the chassis. These cards include the following: The Switch Management Card (SMC) provides management connectivity to the chassis and the Log Processing Card (LPC) handles all log processing and log storage for the firewall.
- b. NPC (Network Processing Card) - The PA-7080 may contain up to ten (10) NPC cards. At least one (1) Network Processing Cards (NPC) must be installed before the firewall can process data traffic. The PA-7000-20GXM-NPC and PA-7000-20GQXM-NPC doubles the memory of the PA-7000-20G-NPC and PA-7000-20GQ-NPC respectively, enabling support for eight million sessions (up from four million).
- c. NPC - With the four (4) standard status LED, each networking interface contains two (2) LED, the link status and activity LED.
- d. PA-7080 - Status LED count (52) includes the following: 4 for fan status, 12 for the LPC and 20 for the SMC, 16 for power supplies.

## Identification and Authentication Policy

### *Assumption of Roles*

The modules support four distinct operator roles, User and Cryptographic Officer (CO), Remote Access VPN, and Site-to-site VPN. The cryptographic modules enforce the separation of roles using unique authentication credentials associated with operator accounts. The modules support concurrent operators.

The modules do not provide a maintenance role or bypass capability.

**Table 16 - Roles and Required Identification and Authentication**

Role	Description	Authentication Type	Authentication Data
CO	This role has access to all configuration, show status and update services offered by the modules. Within the PAN-OS software, this role maps to the "Superuser" administrator role.	Identity-based operator authentication	Username/password and/or public-key/certificate based authentication
User	This role has limited access to services offered by the modules. This role does not have access to modify or view the passwords associated with other administrator accounts; it may not view CSPs of any type stored on the module. The User may change their own password. Within the PAN-OS software, this role maps to the "Superuser (read-only)" administrator role (also referred to as "Superreader").	Identity-based operator authentication	Username/password and/or public-key/certificate based authentication
Remote Access VPN (RA VPN)	Remote user accessing the network via VPN.	Identity-based operator authentication	Username/password and/or certificate based authentication
Site-to-site VPN (S-S VPN)	Remote VPN device establishing a VPN session to facilitate access to the network.	Identity-based operator authentication	IKE/IPSec Pre-shared keys - Identification with the IP Address and authentication with the Pre-Shared Key or certificate based authentication

Table 17 - Strengths of Authentication Mechanisms

Authentication Mechanism	Strength of Mechanism
Username and Password	<p>Minimum length is 6 characters (95 possible characters). The probability that a random attempt will succeed or a false acceptance will occur is <math>1/(95^6)</math> which is less than <math>1/1,000,000</math>. The probability of successfully authenticating to the module within one minute is <math>10/(95^6)</math>, which is less than <math>1/100,000</math>. The firewall's configuration supports at most ten failed attempts to authenticate in a one-minute period.</p>
Public-Key/Certificate based authentication	<p>The security modules support public-key based authentication using RSA 2048 and certificate-based authentication using RSA 2048, RSA 3072, ECDSA P-256, P-384, or P-521.</p> <p>For RSA, the minimum equivalent strength supported is 112 bits. The probability that a random attempt will succeed is <math>1/(2^{112})</math> which is less than <math>1/1,000,000</math>. The probability of successfully authenticating to the module within a one minute period is <math>3,600,000/(2^{112})</math>, which is less than <math>1/100,000</math>. The firewall supports at most 60,000 new sessions per second to authenticate in a one-minute period.</p> <p>For ECDSA, the minimum equivalent strength supported is 128 bits. The probability that a random attempt will succeed is <math>1/(2^{128})</math> which is less than <math>1/1,000,000</math>. The probability of successfully authenticating to the module within a one minute period is <math>3,600,000/(2^{128})</math>, which is less than <math>1/100,000</math>. The firewall supports at most 60,000 new sessions per second to authenticate in a one-minute period.</p>
IKE/IPSec pre-shared keys	<p>The 160 bit key length supports <math>2^{160}</math> different combinations. The probability of successfully authenticating to the module is <math>1/(2^{160})</math>, which is less than <math>1/1,000,000</math>. The number of authentication attempts is limited by the number of new connections per second supported (120,000) on the fastest platform of the Palo Alto Networks firewalls. The probability of successfully authenticating to the module within a one minute period is <math>7,200,000/(2^{160})</math>, which is less than <math>1/100,000</math>.</p>

## Access Control Policy

### *Roles and Services*

The Approved and non-Approved mode of operation provide identical services. While in the Approved mode of operation all CO and User services are accessed via SSH or TLS sessions. Approved and allowed algorithms, relevant CSPs, and public keys related to these protocols are accessed to support the following services. CSP access by services is further described in the following tables.

The services listed below are also available in the non-Approved mode. In the Non-Approved mode, SSH, TLS, and VPN processes will use non-Approved Algorithms and Approved algorithms with non-Approved strength.

**Table 18 - Authenticated Service Descriptions**

Service	Description
Security Configuration Management	Configuring and managing cryptographic parameters and setting/modifying security policy, creating User accounts and additional CO accounts, as well as configuring usage of third party external HSMs.
Other Configuration	Networking parameter configuration, logging configuration, and other non-security relevant configuration.
View Other Configuration	Read-only of non-security relevant configuration (see above).
Show Status	View status via the web interface, command line interface or VPN session.
VPN	Provide network access for remote users or site-to-site connections.
Firmware update	Provides a method to update the firmware on the firewall.

**Note: Additional information on the services the module provides can be found at <https://www.paloaltonetworks.com/documentation.html>**

**Table 19 - Authenticated Services**

Service	Crypto Officer	User	RA VPN	S-S VPN
Security Configuration Management	Y	Y <sup>(a)</sup>	N	N
Other Configuration	Y	N	N	N
View Other Configuration	Y	Y	N	N
Show Status	Y	Y	Y	Y
VPN	N	N	Y	Y
Firmware update	Y	N	N	N

a. The User role has use of this service only to change their own password.

### ***Unauthenticated Services***

The cryptographic module supports the following unauthenticated services:

**Table 20 - Unauthenticated Services**

<b>Service</b>	<b>Description</b>
Zeroize	The device will overwrite all CSPs.
Self-Tests	Run power up self-tests on demand by power cycling the module.
Show Status (LEDs)	View status of the module via the LEDs.

The zeroization procedure is invoked when the operator exits CC (FIPS) mode. The procedure consists of overwriting keystore files, formatting the harddisk, and overwriting with a reinstalled firmware image. The operator must be in control of the module during the entire procedure to ensure that it has successfully completed. During the zeroization procedure, no other services are available.

### ***Definition of Critical Security Parameters (CSPs)***

The modules contain the following CSPs:

**Table 21 - CSPs**

<b>CSP #</b>	<b>CSP/Key Name</b>	<b>Type</b>	<b>Description</b>
1	RSA Private Keys	RSA	RSA Private keys for generation of signatures, authentication or key establishment. (RSA 2048 or 3072-bit)
2	ECDSA Private Keys	ECDSA	ECDSA Private key for generation of signatures and authentication (P-256, P-384, or P-521)
3	TLS PreMaster Secret	TLS Secret	Secret value used to derive the TLS session keys
4	TLS DH Private Components	DH	Diffie-Hellman private FFC or EC component used in TLS (DHE 2048, ECDHE P-256, P-384, P-521)
5	TLS HMAC Keys	HMAC	TLS integrity and authentication session keys (SHA-1, SHA-256, SHA-384)
6	TLS Encryption Keys	AES	TLS encryption session keys (128 and 256 CBC or GCM)
7	SSH Session Authentication Keys	HMAC	Authentication keys used in all SSH connections to the security module's command line interface.(SHA-1)



CSP #	CSP/Key Name	Type	Description
8	SSH Session Encryption Keys	AES	Used in all SSH connections to the security module's command line interface. (128, 192, and 256 CBC or CTR)
9	SSH DH Private Components	DH	Diffie Hellman private component used in key establishment (DHE 2048, ECDHE P-256, P-384, P-521)
10	S-S VPN IPSec/IKE authentication Keys	HMAC	(SHA-1, SHA-256, SHA-384 or SHA-512) Used to authenticate the peer in an IKE/IPSec tunnel connection.
11	S-S VPN IPSec/IKE session Keys	AES	Used to encrypt IKE/IPSec data. These are AES (128, 192, and 256 CBC) IKE keys and (128, 192, and 256 CBC, 128 CCM, 128 and 256 GCM) IPSec keys
12	S-S VPN IPSec/IKE Diffie Hellman Private Components	DH	Diffie-Hellman private component used in key establishment (DHE 2048, ECDHE P-256, P-384)
13	S-S VPN IPSec Pre-Shared Keys	Part of HMAC	Manually distributed by an administrator in the CO role. Used in authentication.
14	RA VPN IPSec session Keys	AES	(128 CBC ) Used to encrypt remote access sessions utilizing IPSec.
15	RA VPN IPSec authentication HMAC	HMAC	(SHA-1) Used in authentication of remote access IPSec data.
16	Password	Password	Authentication string with a minimum length of 6 characters.
17	DRBG Seed /State	DRBG	Used by DRBG. The state includes the V and the Key.
18	SNMPv3 Secrets	SNMPv3 Secrets	SNMPv3 Authentication Secret and Privacy Secret
19	SNMPv3 Keys	SNMPv3 Keys	AES-128 Privacy key and HMAC-SHA-1 Authentication key

Note: The CSPs in Volatile memory locations are zeroized by overwrite with a pseudo random pattern followed by read-verify. Intermediate plaintext key material (CSP) is zeroized when it is copied from one to another memory location. All keys (CSPs) are zeroized when they expire. Session keys (CSPs) are zeroized as soon as the associated session has ended/timed out/ or been closed. Private keys (CSPs) are zeroized when their corresponding public keys (certificates) expire.

**Definition of Public Keys**

The modules contain the following public keys:

**Table 22 - Public Keys**

#	Key Name	Description
A.	CA Certificates	RSA and/or ECDSA keys used to extend trust for certificates
B.	ECDSA Public Keys / Certificates	ECDSA Public keys managed as certificates for the verification of signatures, establishment of TLS, operator authentication and peer authentication.  (ECDSA P-256, P-384, or P-521)
C.	RSA Public Keys / Certificates	RSA Public keys managed as certificates for the verification of signatures, establishment of TLS, operator authentication and peer authentication.  (RSA 2048 or 3072-bit)
D.	TLS DH Public Components	Used in key agreement (DHE 2048, ECDHE P-256, P-384, P-521)
E.	SSH DH Public Components	Used in key agreement (DHE 2048, ECDHE P-256, P-384 and P-521)
F.	SSH Host Public Key	SSH Host Public Key (RSA 2048, ECDSA P-256, P-384, or P-521)  (The matching private key is among the RSA Private Keys or ECDSA Private Keys, in Table 21.)
G.	SSH Client Public Key	SSH Client RSA Public Key (RSA 2048)
H.	S-S VPN - IPSec/IKE Diffie Hellman Public Component	Used in key agreement (DHE 2048, ECDHE P-256, P-384)
I.	Public Key for firmware content load test	Used to authenticate firmware and content to be installed on the firewall (RSA 2048)
J.	Firmware integrity verification Key	Public key used to validate firmware integrity at power-up (ECDSA P-256)

### Definition of CSPs Modes of Access

Table 23 defines the relationship between access to CSPs and the different module services. The modes of access shown in the table are defined as:

- **R = Read:** The module reads the CSP. The read access is typically performed before the module uses the CSP.
- **W = Write:** The module writes the CSP. The write access is typically performed after a CSP is imported into the module, or the module generates a CSP, or the module overwrites an existing CSP.
- **Z = Zeroize:** The module zeroizes the CSP.

**Table 23 - CSP Access Rights within Roles & Services**

Role	Authorized Service	Mode	Cryptographic Key or CSP
CO	Security Configuration Management	RW	1, 2, 3, 4, 5, 6, 7, 8, 9, 16, 17, 18, 19, A, B, C, D, E, F, G, I
CO	Other Configuration	RW	1, 2, 3, 4, 5, 6, 7, 8, 9, A, B, C, D, E, F, G
User, CO	View Other Configuration	RW	1, 2, 3, 4, 5, 6, 7, 8, 9, A, B, C, D, E, F, G
User	Security Configuration Management	RW	1, 2, 3, 4, 5, 6, 7, 8, 9, A, B, C, D, E, F, G, 16 (operator's own password)
User, CO	Show Status	R	1, 2, 3, 4, 5, 6, 7, 8, 9, A, B, C, D, E, F, G
Unauthenticated	Zeroize	Z	All CSPs are zeroized.
S-S VPN	VPN	R	10, 11, 12, 13, B, C, H
RA VPN	VPN	R	1, 2, 3, 4, 5, 6, 14, 15, A, B, C, D
CO	Firmware Update	RW	1, 2, 3, 4, 5, 6, 7, 8, 9, A, B, C, D, E, F, G
Unauthenticated	Self-Tests	N/A	J (R)
Unauthenticated	Show Status (LEDs)	N/A	N/A

## Operational Environment

The FIPS 140-2 Area 6 Operational Environment requirements are not applicable because the Firewalls do not contain modifiable operational environments. The operational environment is limited since the modules include a firmware load service to support necessary updates. New firmware versions within the scope of this validation must be validated through the FIPS 140-2 CMVP. Any other firmware loaded into these modules is out of the scope of this validation and requires a separate FIPS 140-2 validation.

## Security Rules

The module design corresponds to the module security rules. This section documents the security rules enforced by the cryptographic module to implement the security requirements of this FIPS 140-2 Level 2 module.

### ***FIPS 140-2 Security Rules***

1. The cryptographic module provides four distinct operator roles. These are the User role, Remote Access VPN role, Site-to-site VPN role, and the Cryptographic Officer role.
2. The cryptographic module provides identity-based authentication.
3. The cryptographic module clears previous authentications on power cycle.
4. When the module has not been placed in a valid role, the operator does not have access to any cryptographic services.
5. The cryptographic module performs the following tests
  - A. Power up Self-Tests
    1. Cryptographic algorithm tests
      - a. AES Encrypt Known Answer Test
      - b. AES Decrypt Known Answer Test
      - c. AES GCM Encrypt Known Answer Test
      - d. AES GCM Decrypt Known Answer Test
      - e. AES CCM Encrypt Known Answer Test
      - f. AES CCM Decrypt Known Answer Test
      - g. RSA Sign Known Answer Test
      - h. RSA Verify Known Answer Test
      - i. RSA Encrypt Known Answer Test
      - j. RSA Decrypt Known Answer Test
      - k. ECDSA Sign Known Answer Test
      - l. ECDSA Verify Known Answer Test
      - m. HMAC-SHA-1 Known Answer Test
      - n. HMAC-SHA-256 Known Answer Test
      - o. HMAC-SHA-384 Known Answer Test

- p. HMAC-SHA-512 Known Answer Test
  - q. SHA-1 Known Answer Test
  - r. SHA-256 Known Answer Test
  - s. SHA-384 Known Answer Test
  - t. SHA-512 Known Answer Test
  - u. DRBG SP800-90A Known Answer Tests
  - v. SP 800-90A Section 11.3 Health Tests
  - w. DH Known Answer Test
  - x. ECDH Known Answer Test
- 2. Firmware Integrity Test –verified with HMAC-SHA-256 and ECDSA P-256.
- B. Critical Functions Tests
    - 1. N/A
  - C. Conditional Self-Tests
    - 1. Continuous Random Number Generator (RNG) test – performed on NDRNG and DRBG
    - 2. RSA Pairwise Consistency Test (when a key generation fails, the error message displayed is “Cannot verify key and certificate.”)
    - 3. ECDSA Pairwise Consistency Test (when a key generation fails, the error message displayed is “Cannot verify key and certificate.”)
    - 4. Firmware Load Test – Verify RSA 2048 with SHA-256 signature on firmware at time of load
    - 5. If any conditional test fails, the module will output a description of the error condition.
- 6. The operator can command the module to perform the power-up self-test by cycling power of the module.
  - 7. Power-up self-tests do not require any operator action.
  - 8. Data output is inhibited during power-up self-tests, zeroization and error states.
  - 9. Status information does not contain CSPs or sensitive data that if misused could lead to a compromise of the module.
  - 10. There are no restrictions on which keys or CSPs are zeroized by the zeroization service.
  - 11. The module maintains separation between concurrent operators.
  - 12. The module does not support a maintenance interface or role.
  - 13. The module does not have any external input/output devices used for entry/output of data.
  - 14. The module does not enter or output plaintext CSPs.
  - 15. The module does not output intermediate key generation values.

Vendor imposed security rules:

1. If the cryptographic module remains inactive in any valid role for the administrator specified time interval, the module automatically logs out the operator.
2. The module enforces a timed access protection mechanism that supports at most ten authentication attempts per minute. After the administrator specified number of consecutive unsuccessful password validation attempts have occurred, the cryptographic module shall enforce a wait period of at least one (1) minute before any more login attempts can be attempted. This wait period shall be enforced even if the module power is momentarily removed.

### ***Physical Security Mechanisms***

The multi-chip standalone modules are production quality containing standard passivation. Chip components are protected by an opaque enclosure. There are tamper evident seals that are applied on the modules by the Crypto-Officer. All unused seals are to be controlled by the Crypto-Officer. The seals prevent removal of the opaque enclosure without evidence. The Crypto-Officer must ensure that the module surface is clean and dry. Tamper evident labels must be pressed firmly onto the adhering surfaces during installation and once applied the Crypto-Officer shall permit 24 hours of cure time for all tamper evident labels. The Crypto-Officer should inspect the seals and shields for evidence of tamper every 30 days. If the seals show evidence of tamper, the Crypto-Officer should assume that the modules have been compromised and contact Customer Support.

Note: For ordering information, see Table 2 for FIPS kit part numbers and versions. Opacity shields and Tamper Labels are included in the FIPS kits.

Refer to Appendix A for instructions on installation of the tamper seals and opacity shields. The locations of the five (5) tamper evident seals implemented on the PA-200 are shown in Figure 22 through Figure 23



**Figure 22 - PA-200 Left Side and Top Tamper Seal Placement (3)**



**Figure 23 - PA-200 Right Side Tamper Seal Placement (2)**

Refer to Appendix B for instructions on installation of the tamper seals and opacity shields. The locations of the six (6) tamper evident seals implemented on the PA-220 are shown in Figure 23 through Figure 25.



Figure 24 - PA-220 Front with enclosure

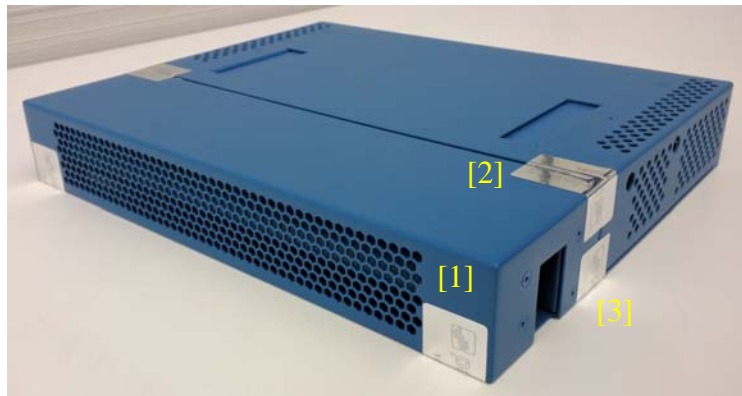

Figure 25 – PA-220 Right Side and Front Tamper Seal Placement (3)

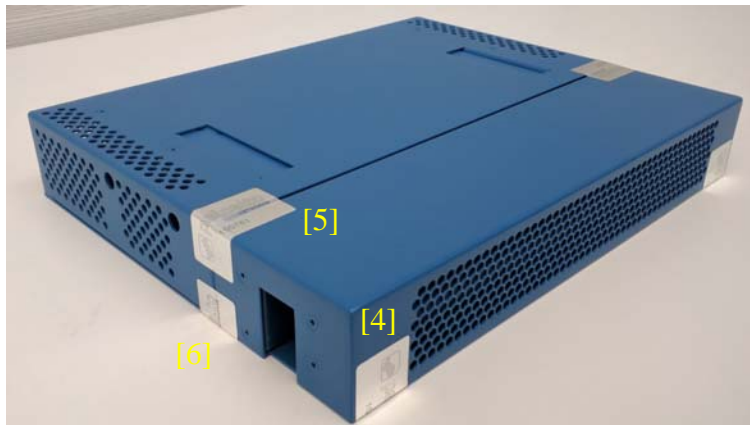

Figure 26 – PA-220 Left Side and Front Tamper Seal Placement (3)



Refer to Appendix C for instructions on installation of the tamper seals and opacity shields. The locations of the twelve (12) tamper evident seals implemented on the PA-500 (and PA-500-2GB) are shown in Figure 26 through Figure 30.

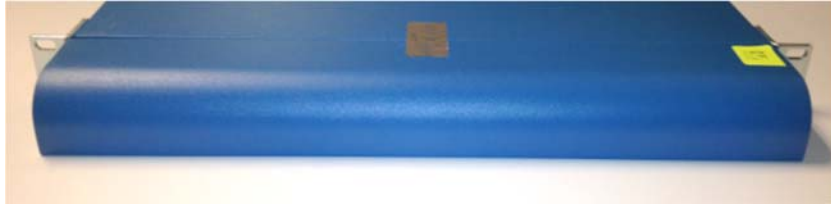

Figure 27 - PA-500 with Front Opacity Shield



Figure 28 - PA-500 Front Tamper Seal Placement (1)

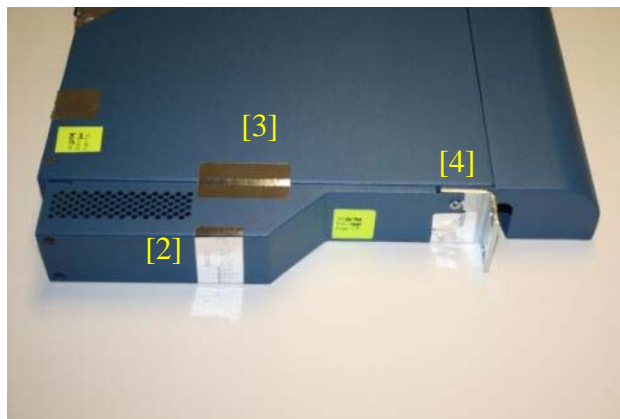

Figure 29 - PA-500 Left Side Tamper Seal Placement (3)

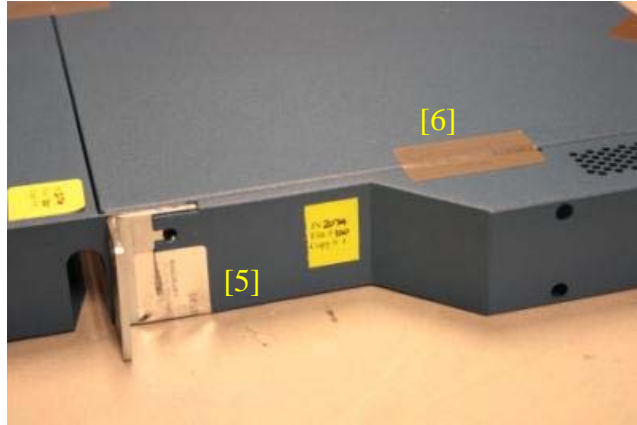

Figure 30 - PA-500 Right Side Tamper Seal Placement (2)

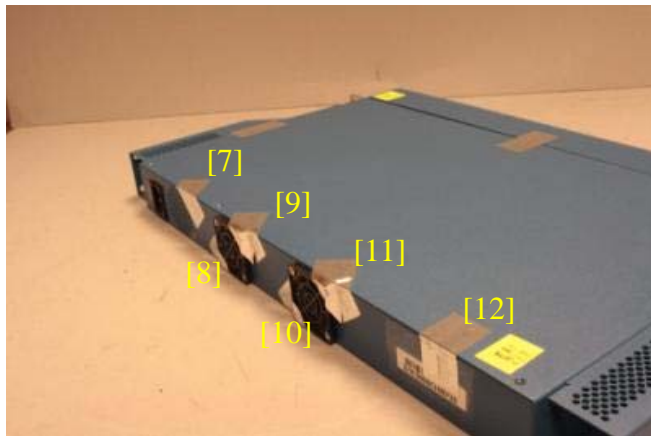
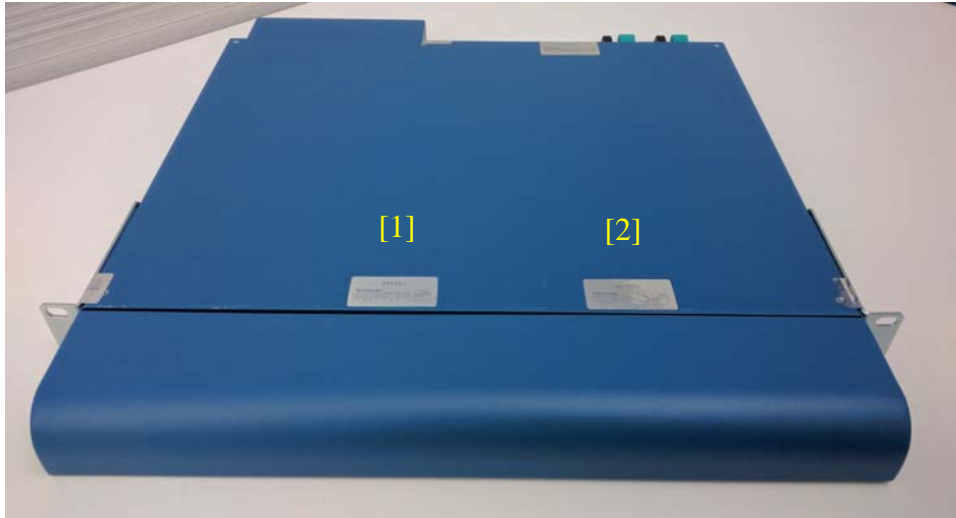
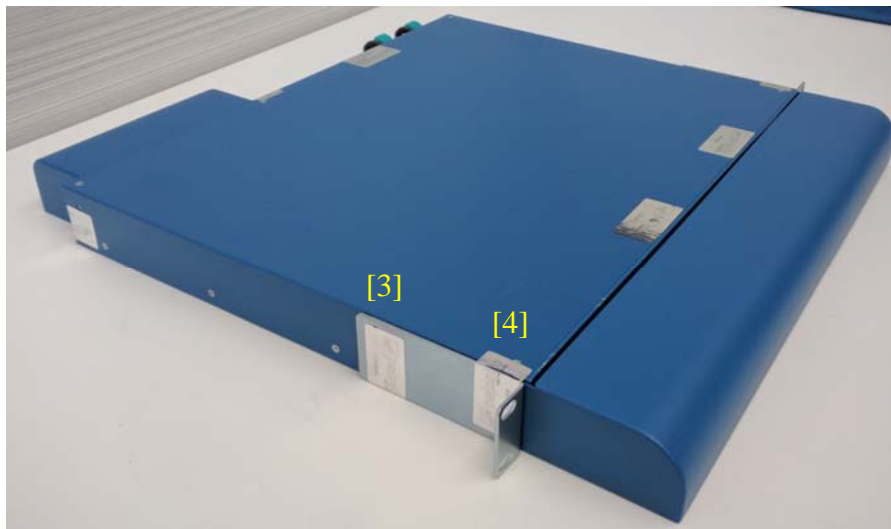

Figure 31 - PA-500 Rear Tamper Seal Placement (6)

Refer to Appendix D for instructions on installation of the tamper seals and opacity shields for the PA-800 series. The locations of the eleven (11) tamper evident seals on the PA-800 Series modules are shown in Figure 31 through Figure 35



**Figure 32 - PA-800 Series Front Tamper Seal Placement with Opacity Shield (2)**



**Figure 33 - PA-800 Series Left Side Front Tamper Seal Placement (2)**

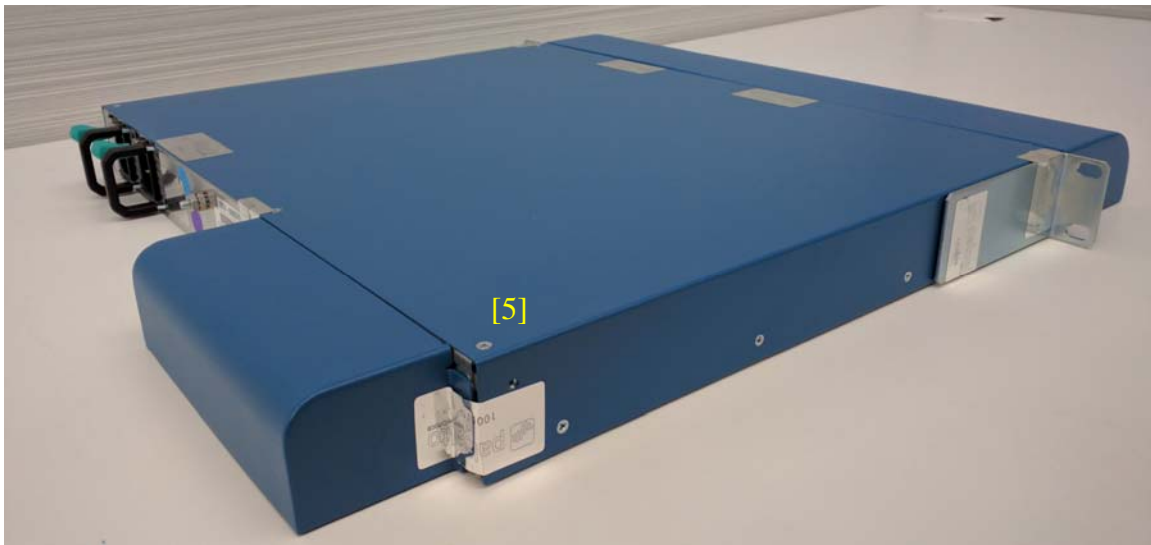

Figure 34 – PA-800 Left Side Rear Tamper Seal Placement (1)



Figure 35 –PA-800 Right Side Rear Tamper Seal Placement (3)

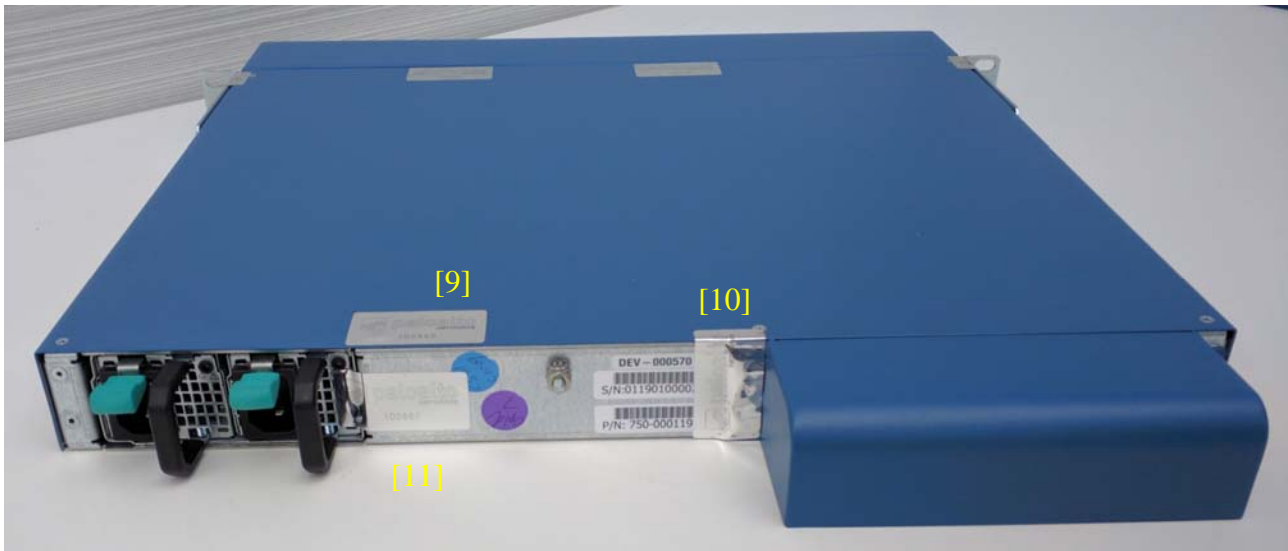

Figure 36 - Rear Tamper Seal Placement (3)

Refer to Appendix E for instructions on installation of the tamper seals and opacity shields for the PA-3020 and PA-3050. The locations of the seven (7) tamper evident seals on the PA-3020/PA-3050 modules are shown in Figure 37 through Figure 40.



Figure 37 - PA-3020 / PA-3050 side with Opacity Shield

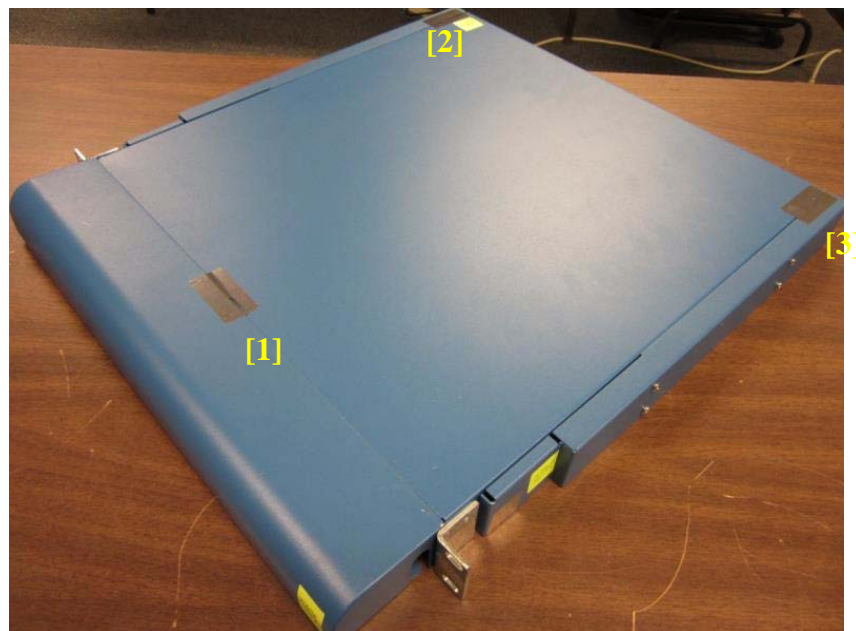

Figure 38 - PA-3020/PA-3050 Series Tamper Seal Placement (3)

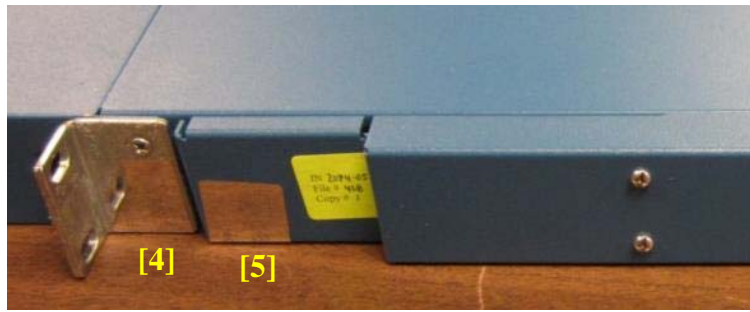

Figure 39 - PA-3020/PA-3050 Series Tamper Seal Placement (2)



Figure 40 - PA-3020/PA-3050 Series Tamper Seal Placement (2)

Refer to Appendix F for instructions on installation of the tamper seals and opacity shields for the PA-3060. The locations of the eight (8) tamper evident seals implemented on the PA-3060 module are shown in Figure 41 through Figure 44.



Figure 41 – PA-3060 Right side



Figure 42 – PA-3060 Left side





Figure 43 – PA-3060 Front/Top Tamper Seal Placement

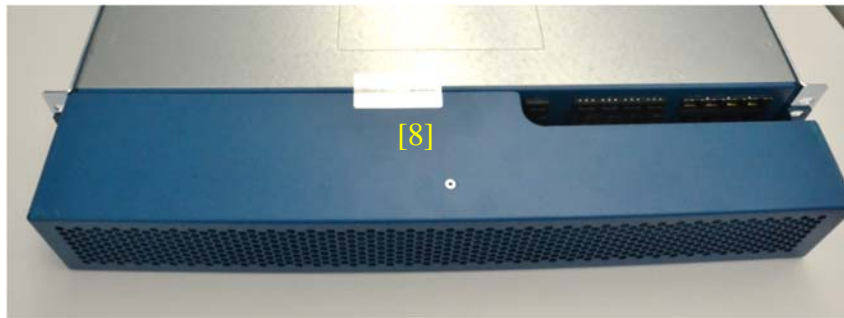

Figure 44 – PA-3060 Front/Bottom Tamper Seal Placement

Refer to Appendix G for instructions on installation of the tamper seals and opacity shields for the PA-5000 series. The locations of the seventeen (17) tamper evident seals implemented on the PA-5000 Series modules are shown in Figure 45 through Figure 47.

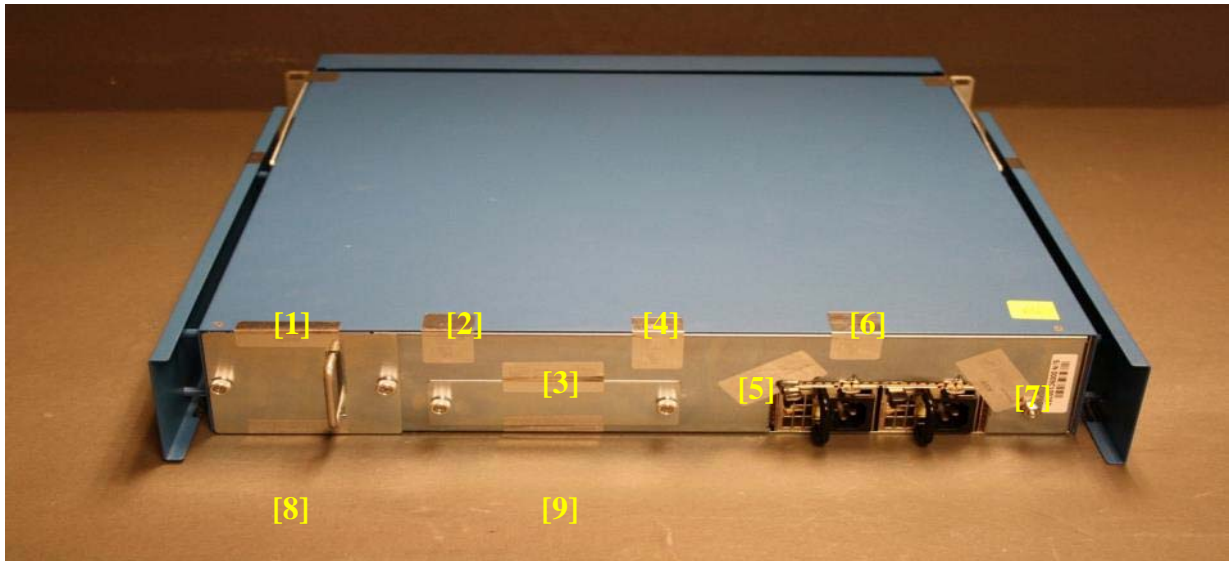

Figure 45 - PA-5000 Series Rear Tamper Seal Placement (9) with opacity shields



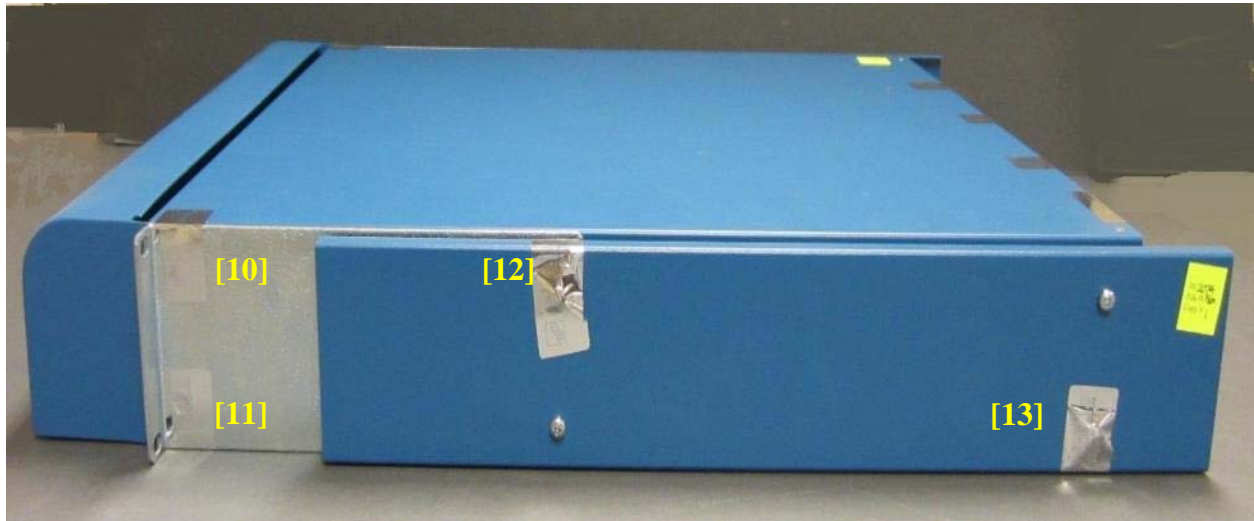

Figure 46 - PA-5000 Series Right Side Tamper Seal Placement (4)



Figure 47 - PA-5000 Series Left Side Tamper Seal Placement (4)

Refer to Appendix H for instructions on installation of the tamper seals and opacity shields for the PA-5200 series. The locations of the twenty-eight (28) tamper evident seals implemented on the PA-5200 Series modules are shown in Figure 48 through Figure 51

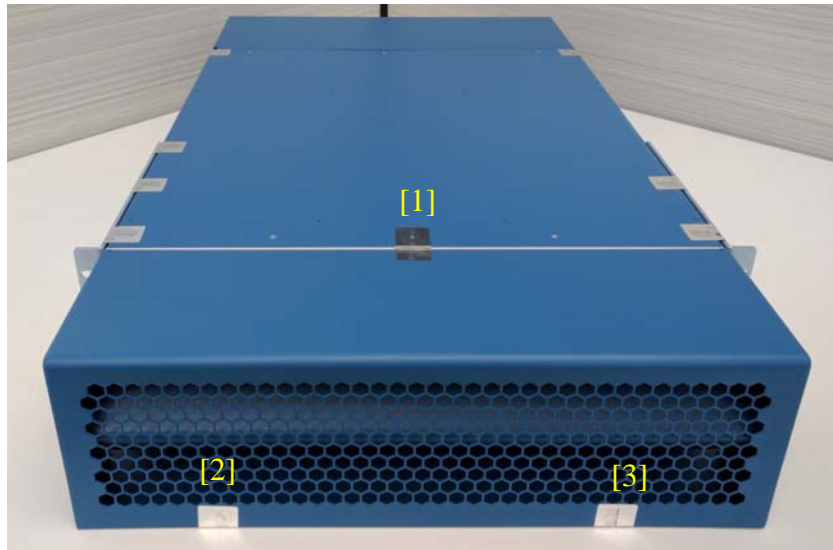

Figure 48 - PA-5200 Series front Opacity Shield

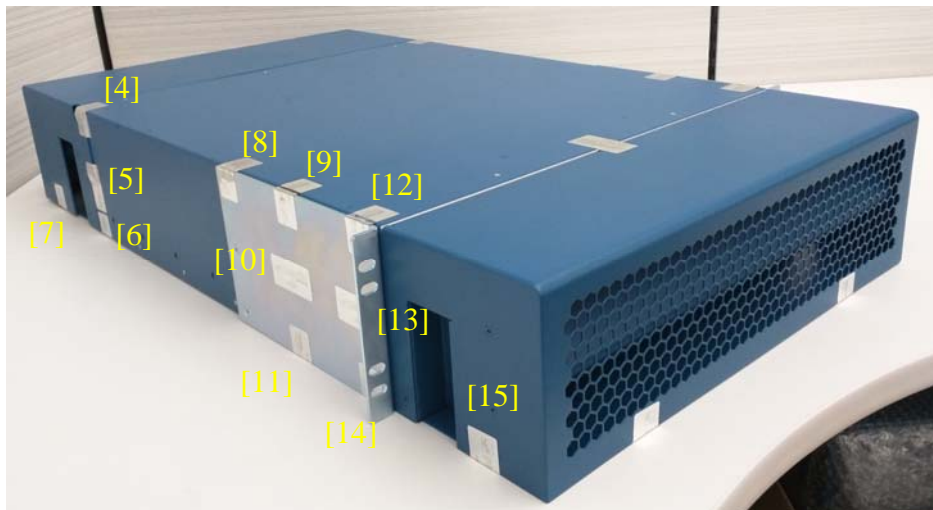

Figure 49 - PA-5200 Series Left Side with Front Opacity Shield

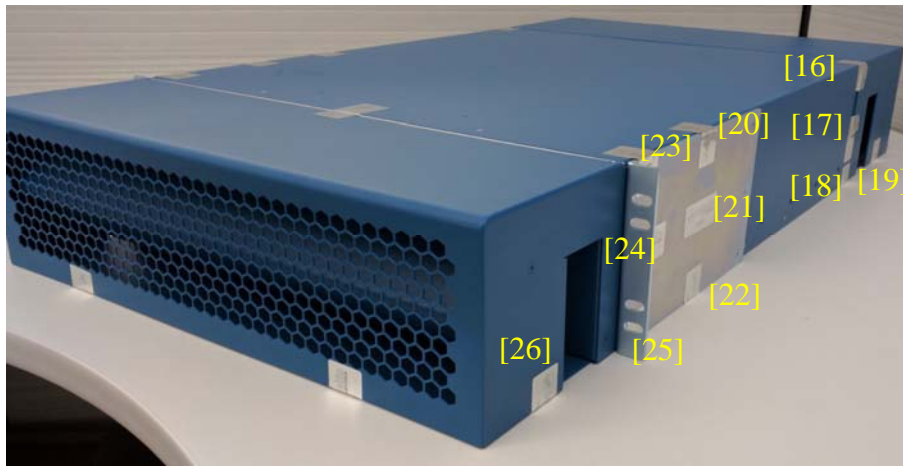

Figure 50 - PA-5200 Series Right Side with Front Opacity Shield



Figure 51 - PA-5200 Series Rear Opacity Shield

Refer to Appendix I for instructions on installation of the tamper seals and opacity shields for the PA-7050. The locations of the twenty-four (24) tamper evident seals implemented on the PA-7050 Series modules are shown in Figure 52 through Figure 60.



Figure 52 - PA-7050 Front View with Opacity Shields



Figure 53 - PA-7050 Rear View with Opacity Shields



Figure 54 - PA-7050 Front and Right Side with Opacity Shields



Figure 55 - PA-7050 Rear and Left Side with Opacity Shields

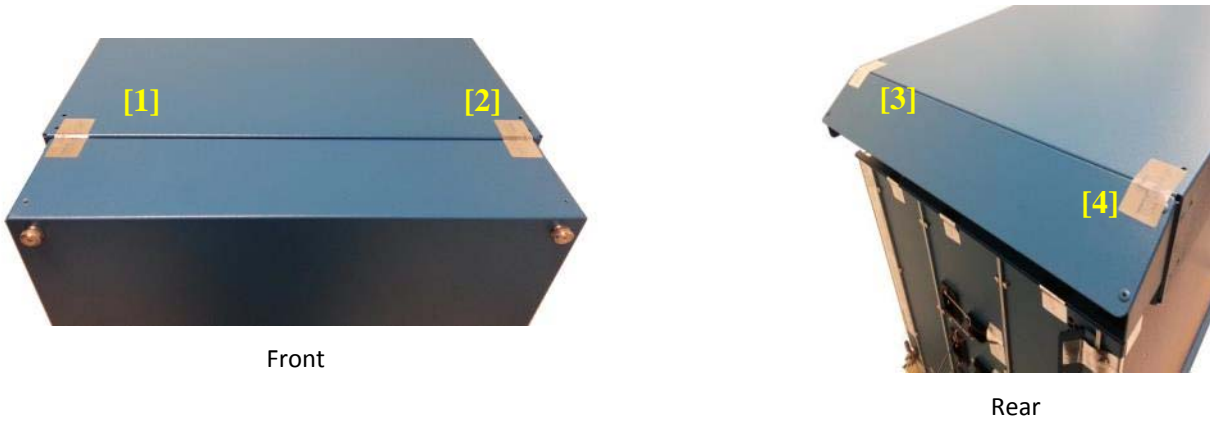

Figure 56 - PA-7050 Tamper Seal Placement for Top Plenum (1-4)

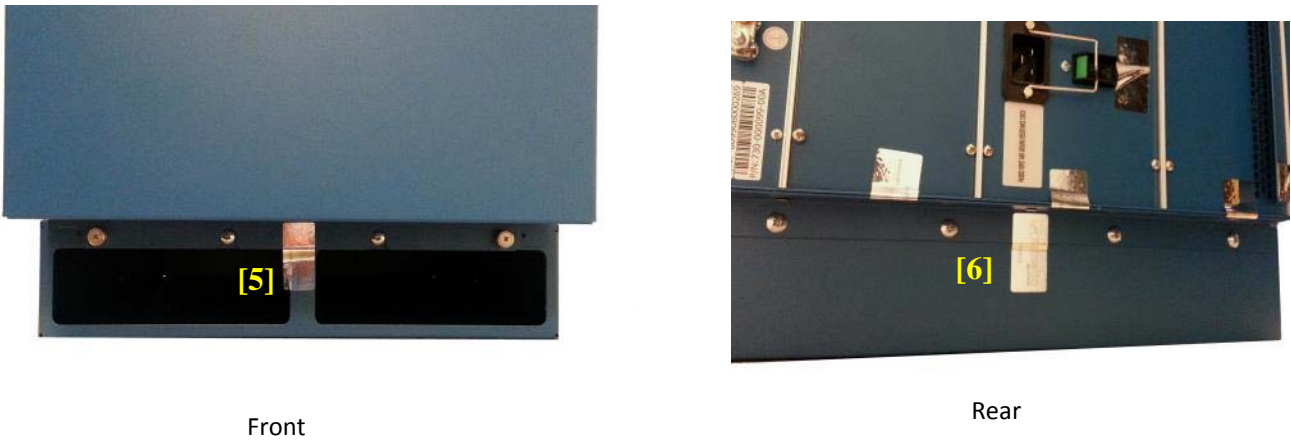

Figure 57 - PA-7050 Tamper Seal Placement for Bottom Plenum (5-6)



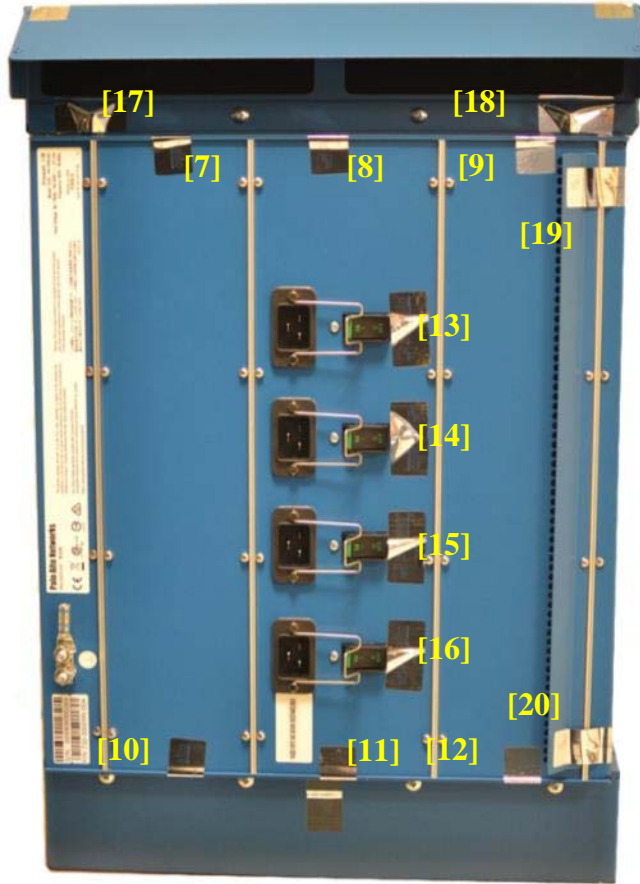

Figure 58 - PA-7050 Tamper Seal Placement for Rear (7-20)



Figure 59 - PA-7050 Tamper Seal Placement for Top Plenum Bracket (21-22)



**Figure 60 - PA-7050 Tamper Seal Placement for Bottom Plenum Bracket (23-24)**

Refer to Appendix J for instructions on installation of the tamper seals and opacity shields for the PA-7080. The locations of the ten (10) tamper evident seals implemented on the PA-7080 Series modules are shown in Figure 61 through Figure 64



Figure 61 - PA-7080 Front with Opacity Shield



Figure 62 - PA-7080 Rear





**Figure 63 - PA-7080 Tamper Seal Placement on Left Side for Front Opacity Shield (1)**

**Figure 64 - PA-7080 Tamper Seal Placement on Right Side for Front Opacity Shield (1)**

### ***Operator Required Actions***

**Table 24 - Inspection/Testing of Physical Security Mechanisms**

<b>Model</b>	<b>Physical Security Mechanisms</b>	<b>Recommended Frequency of Inspection/Test</b>	<b>Inspection/Test Guidance Details</b>
PA-7080, PA-7050, PA-5220, PA-5250, PA-5260, PA-5060, PA-5050, PA-5020, PA-3060, PA-3050, PA-3020, PA-800, PA-500, PA-220, PA-200	Tamper Evident Seals	30 days	<i>Verify integrity of tamper evident seals in the locations identified in the FIPS Kit Installation Guide. Seal integrity to be verified within the modules operating temperature range.</i>
PA-7050	Top, Bottom, Front and Rear Opacity Shields	30 days	<i>Verify that the plenums and opacity shields have not been deformed from their original shape, thereby reducing their effectiveness</i>
PA-5060, PA-5050, PA-5020, PA-3050, PA-3020, PA-500	Front Cover and Side Opacity Shields	30 days	<i>Verify that front cover and side opacity shields have not been deformed from their original shape, thereby reducing their effectiveness</i>
PA-3060	Front and Rear Covers	30 days	<i>Verify that front and rear covers have not been deformed from their original shape, thereby reducing their effectiveness</i>
PA-7080	Front Cover	30 days	<i>Verify that front cover has not been deformed from its original shape thereby reducing its effectiveness</i>
PA-220, PA-200	Front cover and Cage Enclosure	30 days	<i>Verify that front cover and cage enclosure have not been deformed from their original shape, thereby reducing their effectiveness</i>

### **Mitigation of Other Attacks Policy**

The module has not been designed to mitigate any specific attacks outside of the scope of FIPS 140-2, so these requirements are not applicable.

## Definitions and Acronyms

API – Application Programming Interface

App-ID – Application Identification - Palo Alto Networks' ability to identify applications and apply security policy based on the ID rather than the typical port and protocol-based classification.

BGP – Border Gateway protocol – Dynamic routing protocol

CA – Certificate authority

Content-ID – Content Identification – Palo Alto Networks' threat prevention features including Antivirus, Antispyware, and Intrusion Prevention.

CO – Cryptographic Officer

DLP – Data loss prevention

Gbps – Gigabits per second

HA – High Availability

HSCI - High Speed Chassis Interconnect

IKE – Internet Key Exchange

IP – Internet Protocol

IPSec – Internet Protocol Security

LDAP – Lightweight Directory Access Protocol

LED – Light Emitting Diode

NDRNG – Non-deterministic random number generator

OCSP – Online Certificate Status Protocol

OSPF – Open Shortest Path First – Dynamic routing protocol

PAN-OS – Palo Alto Networks' Operating System

QoS – Quality of Service

QSFP - Quad Small Form-factor Pluggable

RA VPN – Remote Access Virtual Private Network

RIP – Routing Information Protocol – Dynamic routing protocol

RJ45 – Networking Connector

RNG –Random number generator

S-S VPN – Site to site Virtual Private Network

SFP – Small Form-factor Pluggable Transceiver

SSL – Secure Sockets Layer

TLS – Transport Layer Security

USB – Universal Serial Bus

User-ID – User Identification – Palo Alto Networks’ ability to apply security policy based on who initiates the traffic rather than the typical IP-based approach.

VPN – Virtual Private Network

XML – Extensible Markup Language

## Reference Documents

FIPS 140-2 - FIPS Publication 140-2 Security Requirements for Cryptographic Modules

## Appendix A - PA-200 - FIPS Accessories/Tamper Seal Installation (5 Seals)

1. Insert the PA-200 unit into the cage.

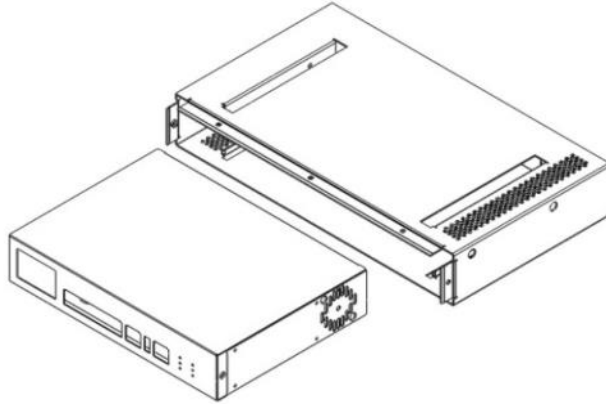

2. Secure right side of the PA-200 unit to the cage with (2x) 4-40x1/2" screws provided in the kit. Repeat for the left side of the cage.

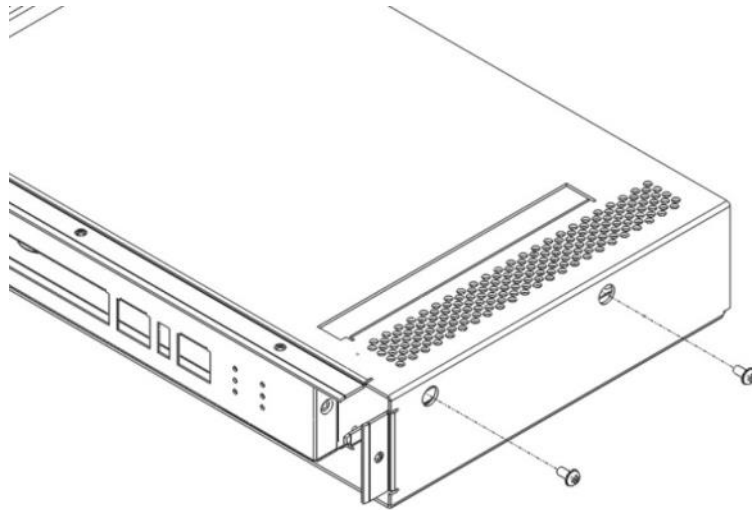

3. Install the front panel with the curve side up to the front cage.

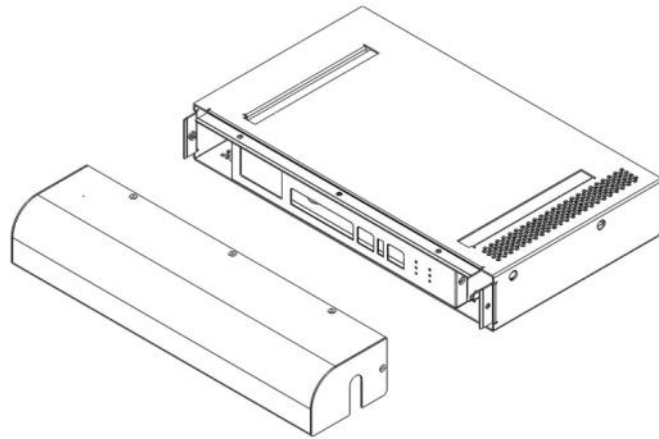

4. Secure the front panel to the cage with (5x) 4-40x3/16" screws.

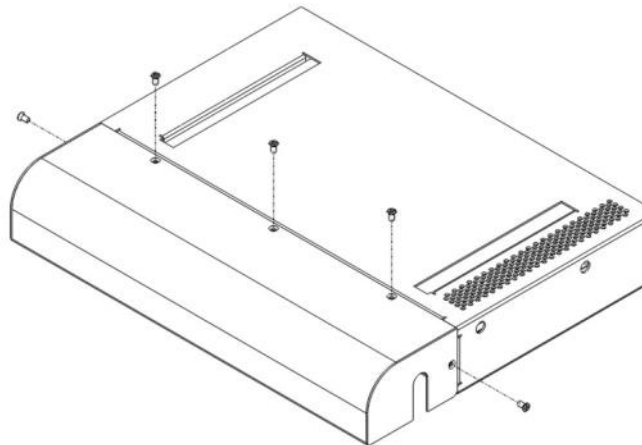

5. Affix a tamper seal on the top middle of the front panel screw.

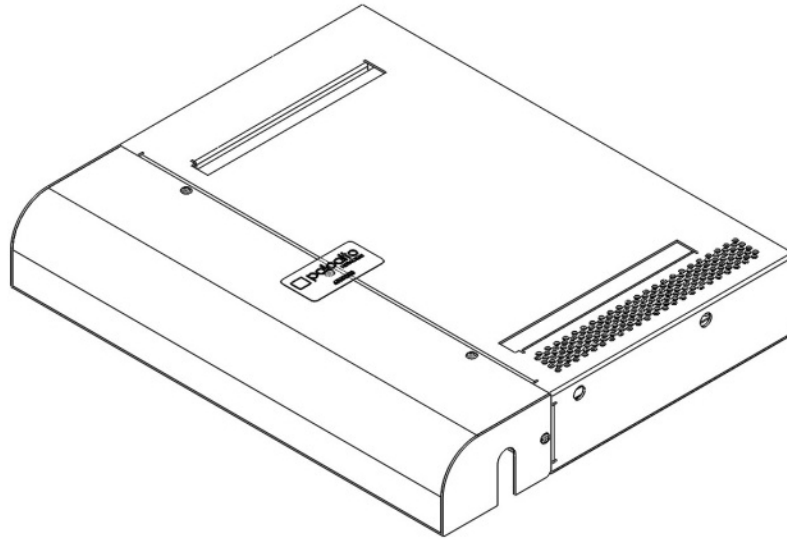

6. Affix two tamper seals over both screw mounting holes on the cage and right side screw on the front panel. Repeat for the left side

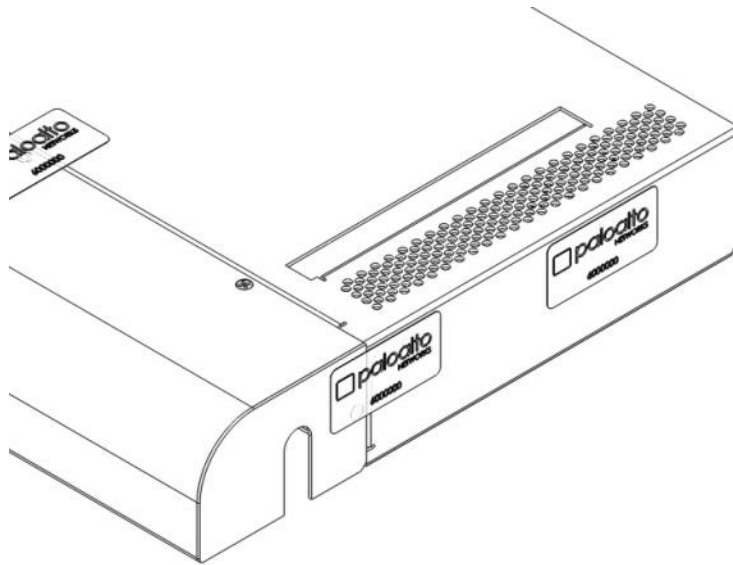

## Appendix B - PA-220 - FIPS Accessories/Tamper Seal Installation (6 Seals)

1. Place the firewall upside down on a flat Electrostatic Discharge (ESD) protected surface and ground yourself by touching a metal surface on the firewall.
2. Slide the firewall in to the FIPS chassis cover and attach it to the cover using a Phillips-head screwdriver to tighten four captive screws (two screws on each side of the cover).

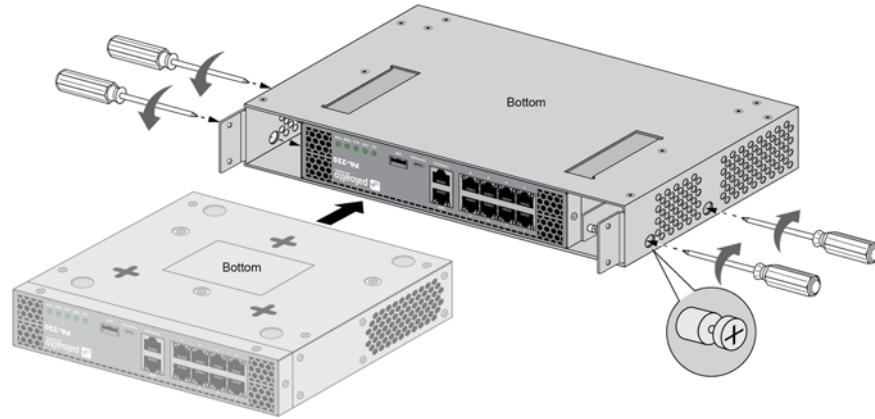

3. Install the front (network, management, and console) cables (you cannot access the front ports after you complete the front-cover install described in the following steps).
4. Place the FIPS front cover onto the FIPS chassis cover and attach it using four #4-40 x .25" screws (two screws on each side of the cover).

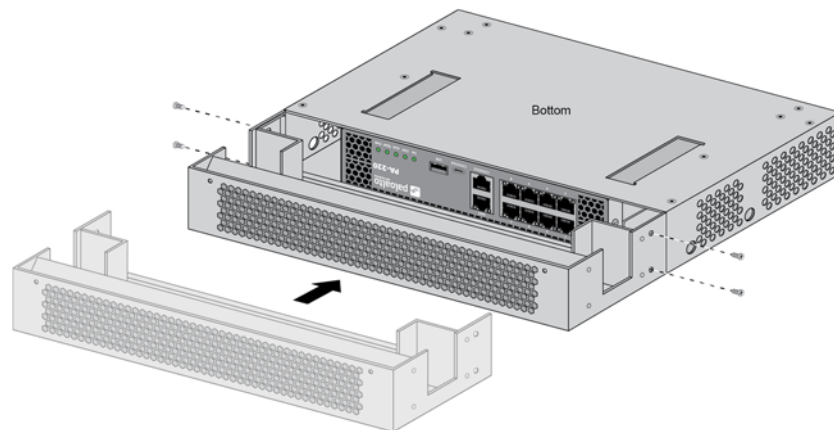

5. Route the front-port cables through the front-cover cable-guide openings.

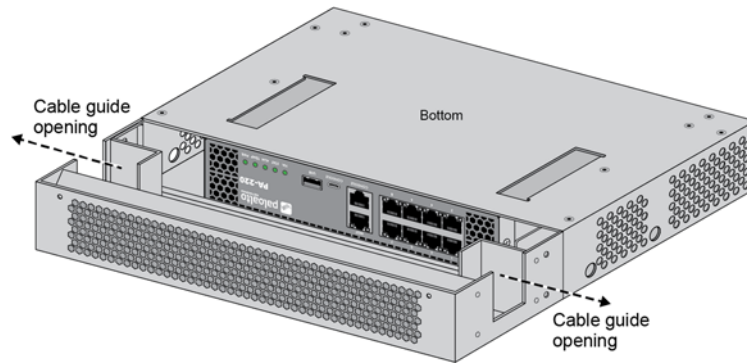

6. Attach the FIPS front-cover panel to the FIPS front cover by sliding the two panel tabs under the FIPS chassis cover and then attach the panel using two #4-40 x .25" screws.

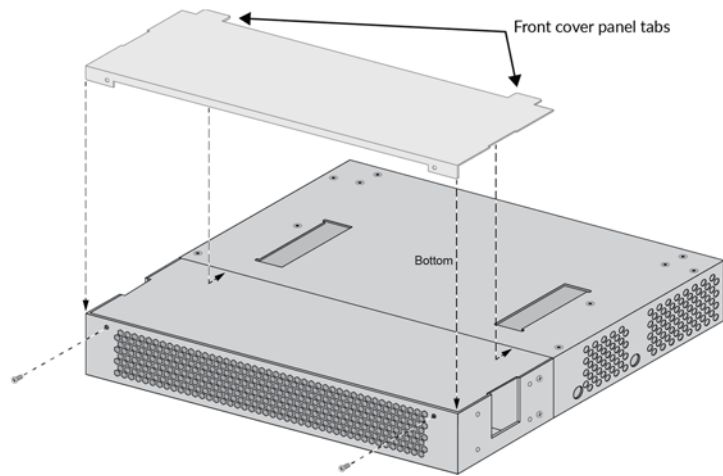

7. Apply a tamper-evident label to each location shown in the following illustration (six labels total). After all labels are applied, place the firewall right-side up.

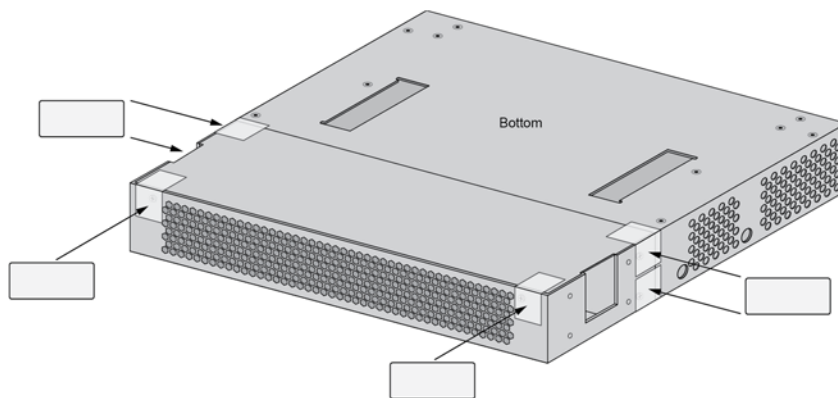



## Appendix C - PA-500 - FIPS Accessories/Tamper Seal Installation (12 Seals)

1. Remove the right side cover screws. Repeat for the left side cover screws.

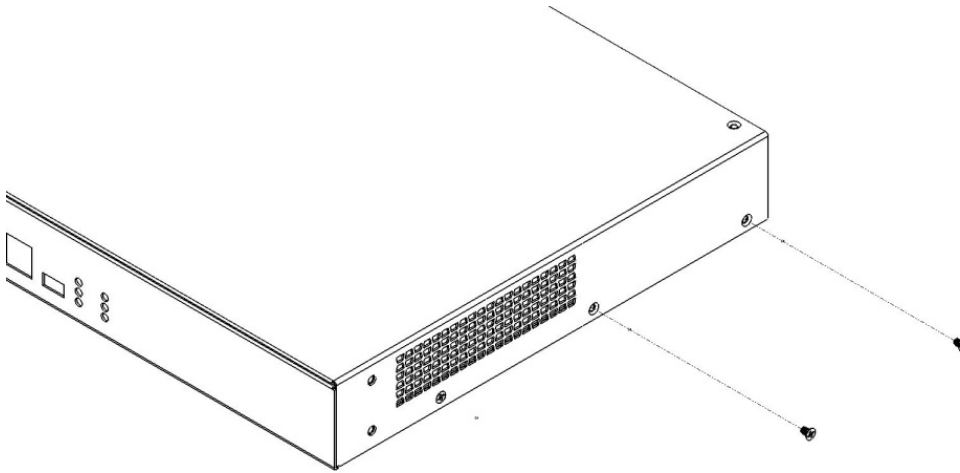

2. Install the right side FIPS opacity shield and secure with 2x #4-40x1/4" SEMS screws provided in the kit. Repeat for the left side.

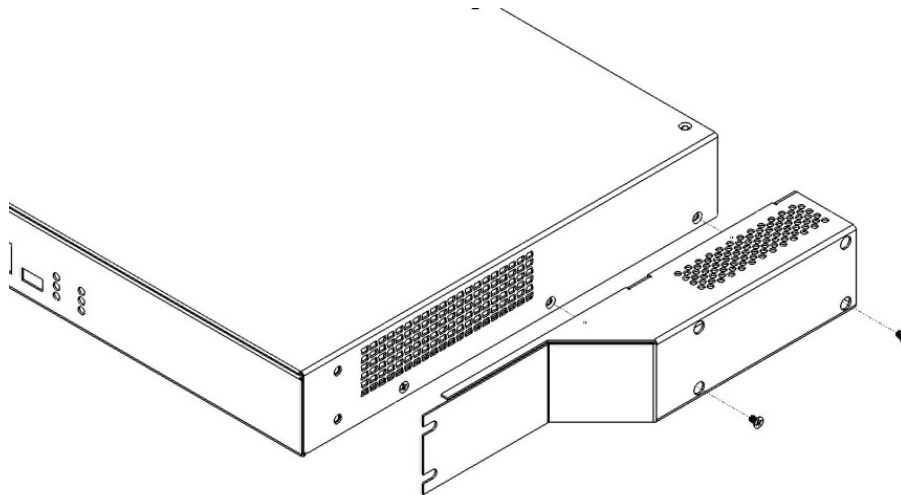

3. Install the front FIPS panel with the curve side up and align with the ear mounting screw holes.

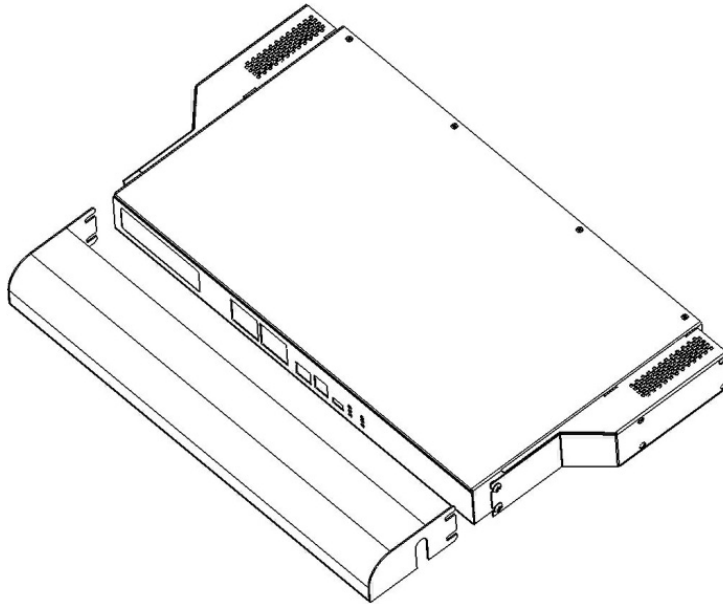

4. Sandwich the right side mounting ear between the front panel and the opacity shield. Repeat with the left side of the chassis.

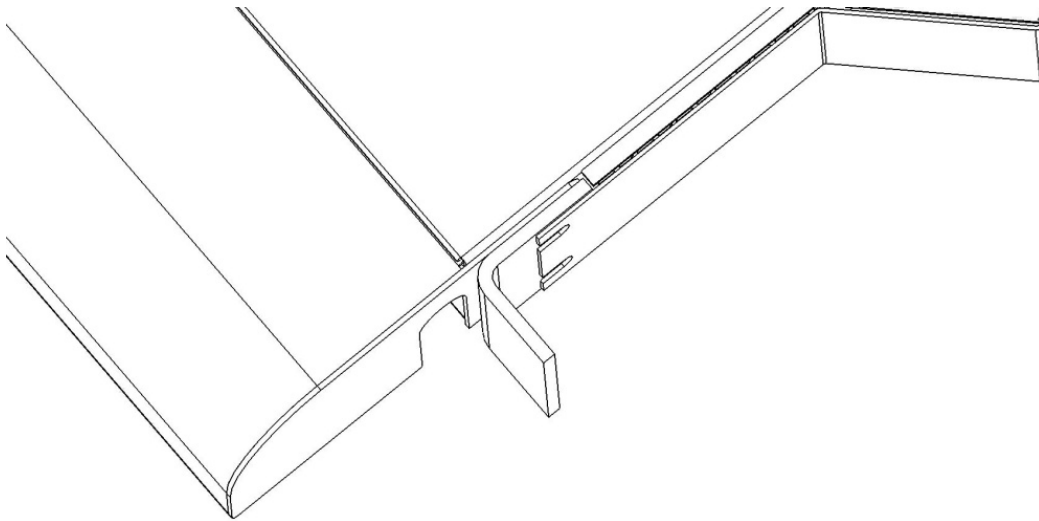

5. Install and secure the right side mounting ear with (2x) #6-32x1/2" Truss screws provided in the kit. Repeat on the left side.

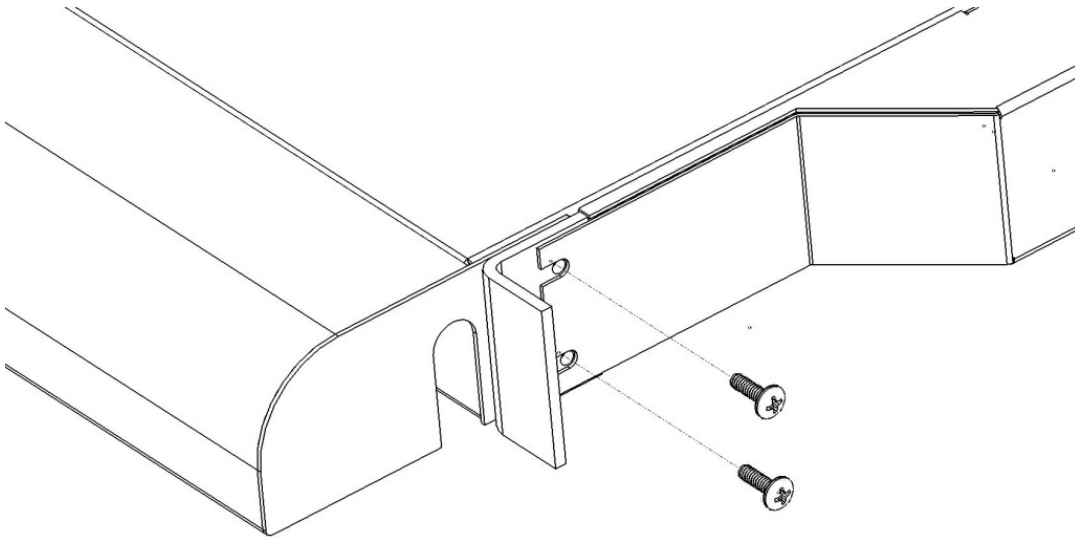

6. Remove 1x upper-right fan screw.

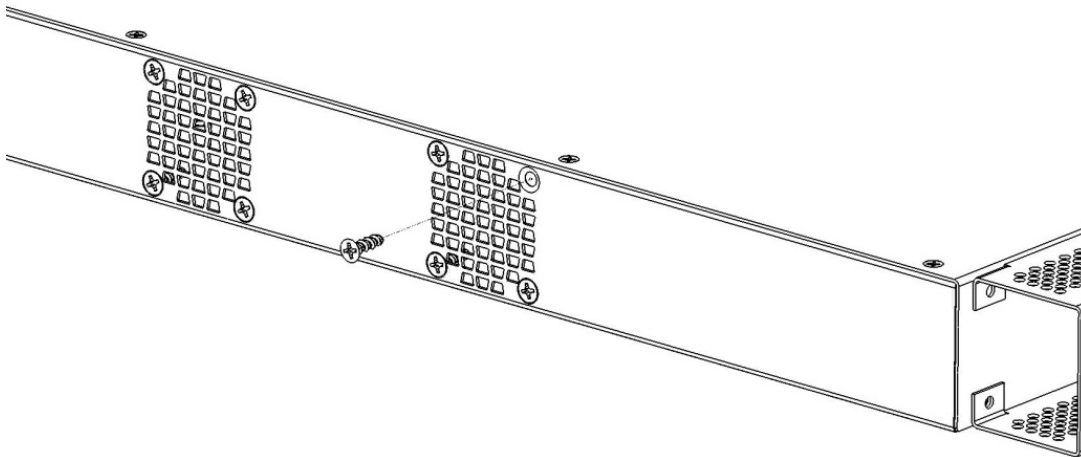

7. Install and partially tighten the screw on one of the fan guard mounting holes.

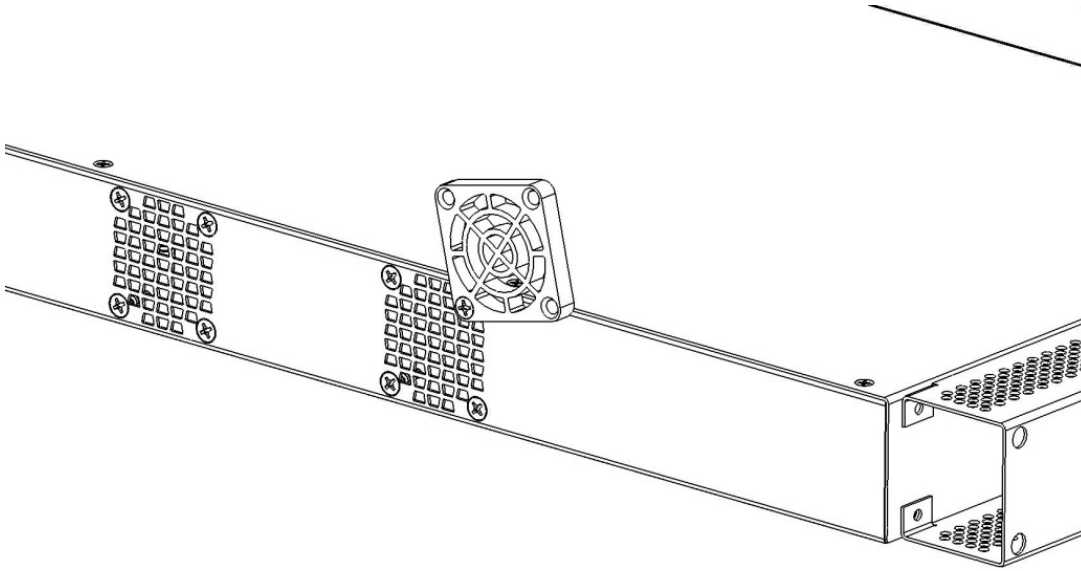

8. Remove the other 3x fan screws.

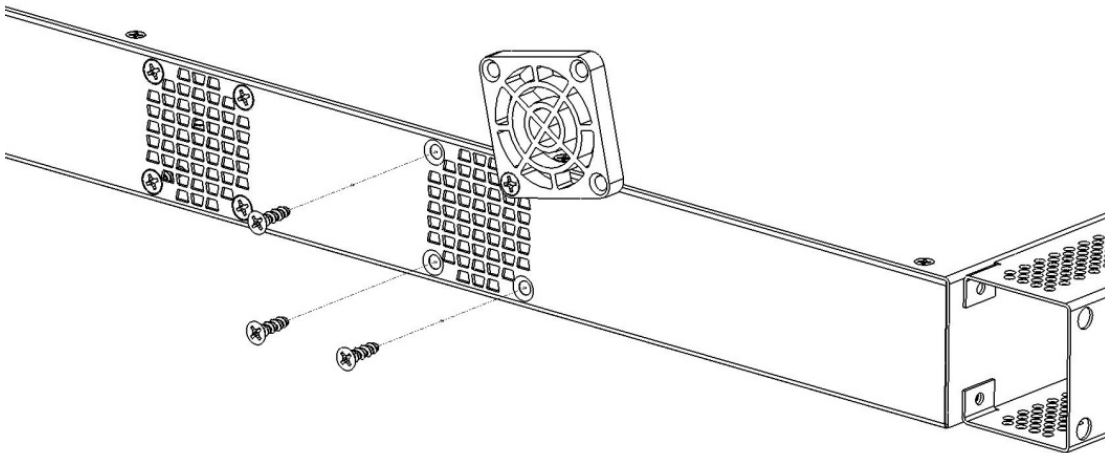

10. Align the fan guard and secure with 3x screws as shown. Repeat the installation steps for the other fan.

Caution: The fan guard may crack if you over-tighten the screws.

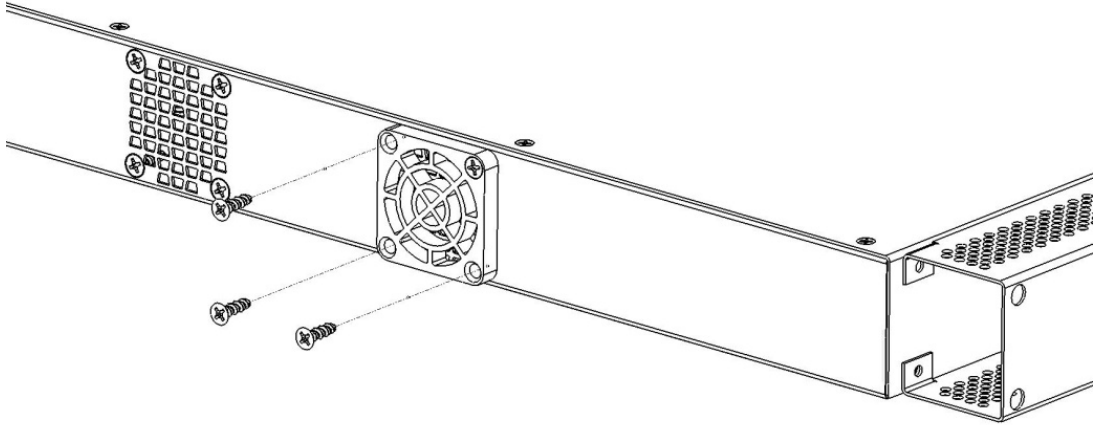

11. Affix one tamper seal over top cover/rear left chassis.

Affix one tamper seal over the upper PSU screw.

Affix four tamper seals over the fan cover screws.

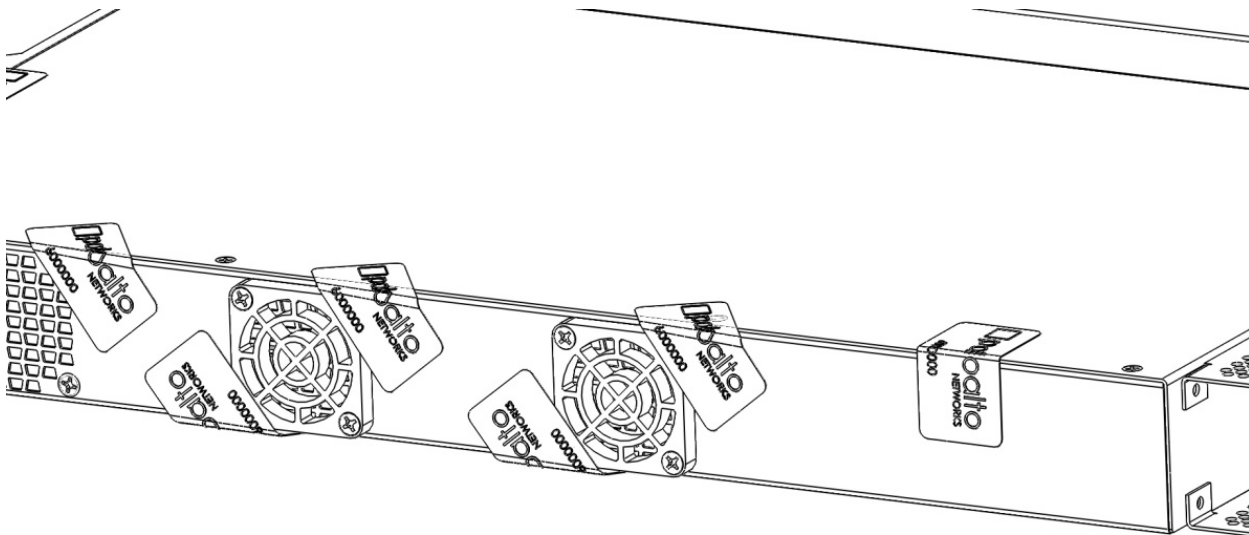

- 12 Affix a tamper seal over both screw access holes on the left side opacity shield.
- Affix a tamper seal over the bottom ear screw on the left side of the chassis.
- Affix a tamper seal on top of the opacity shield/cover on the left side of the chassis.

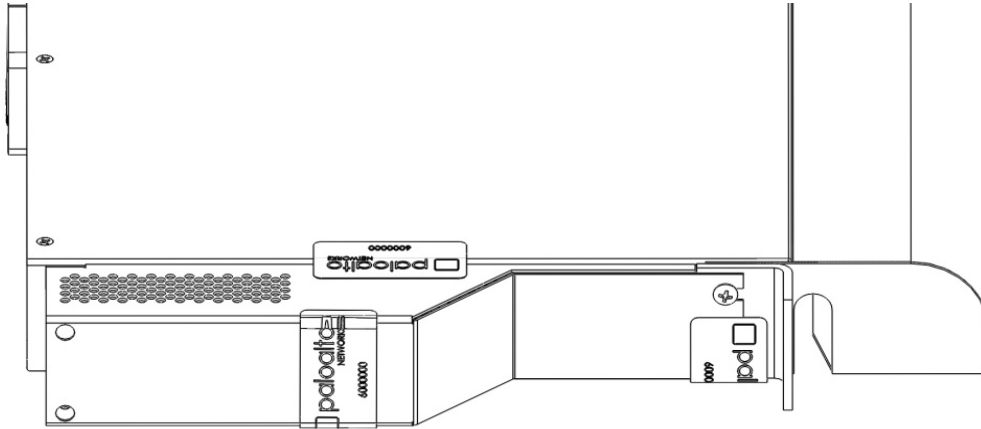

- 13. Affix a tamper seal over the bottom ear screw on the right side of the chassis.
- Affix a tamper seal on top of the opacity shield/cover on the right side of the chassis.

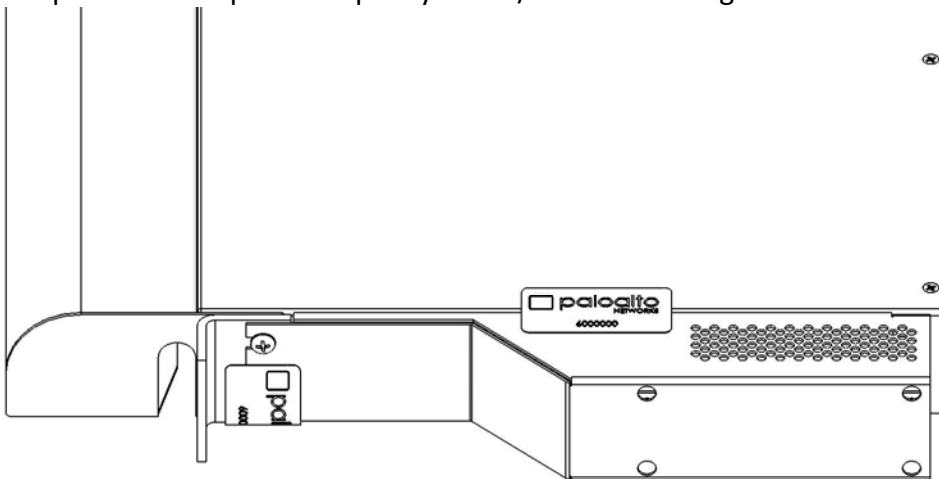

14. Affix a tamper seal on the top of the cover and panel.

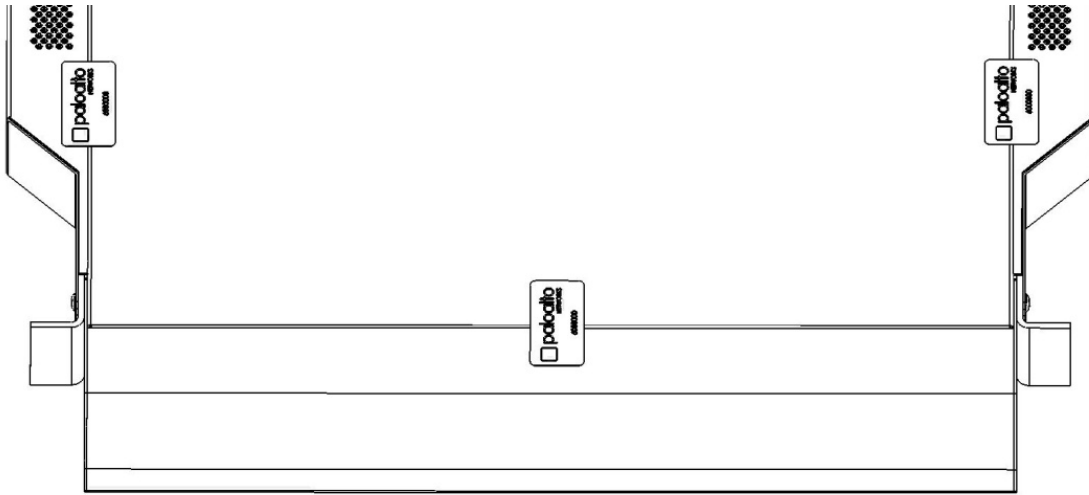

## Appendix D - PA-800 series - FIPS Accessories/Tamper Seal Installation (11 Seals)

1. Place the firewall on a flat Electrostatic Discharge (ESD) protected surface and ground yourself by touching a metal surface on the firewall.
2. Place the FIPS back cover onto the back of the firewall and attach it using four #4-40 x 5/16 screws (two screws on each side of the back cover).

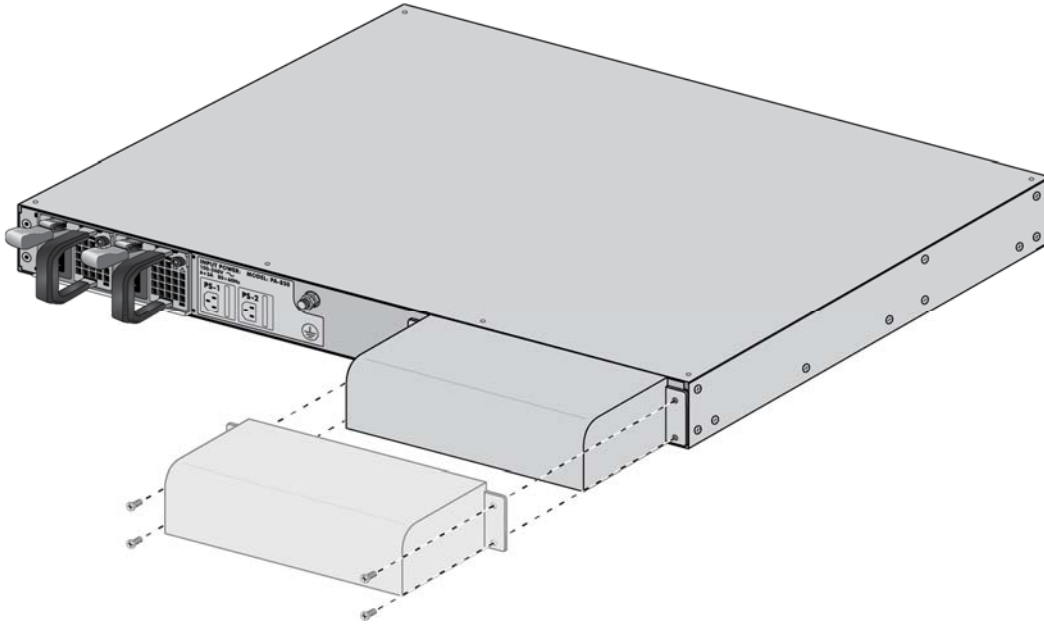

3. Insert the front (network, management, and console) cables in to the front ports.
4. Place the FIPS front cover onto the front of the firewall and place the rack-mount brackets over the holes on the front cover. Attach the front cover and rack-mount brackets to the firewall using eight #6-32 x 5/16" rack-mount bracket screws (shipped with the firewall)—use four screws on each side. Route the front cables through the front-cover cable-guide opening.



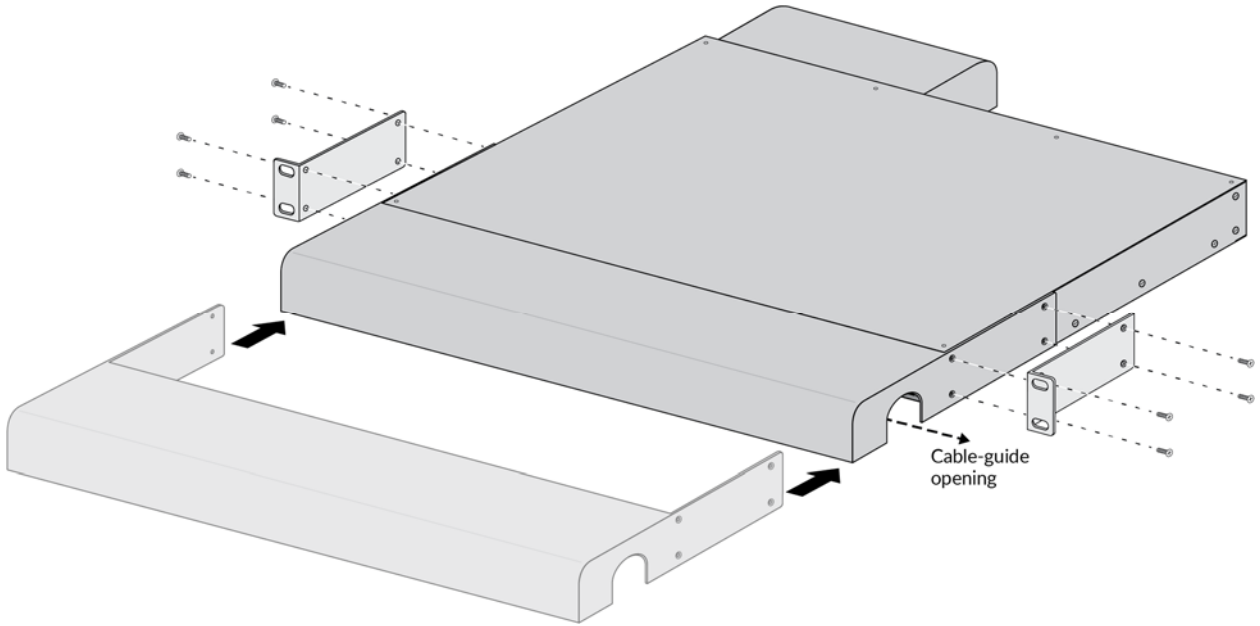

5. Apply a tamper-evident label to each location shown in the following illustrations (11 labels total). The label placement over the power supply of the PA-820 firewall and PA-850 firewall is slightly different as shown.

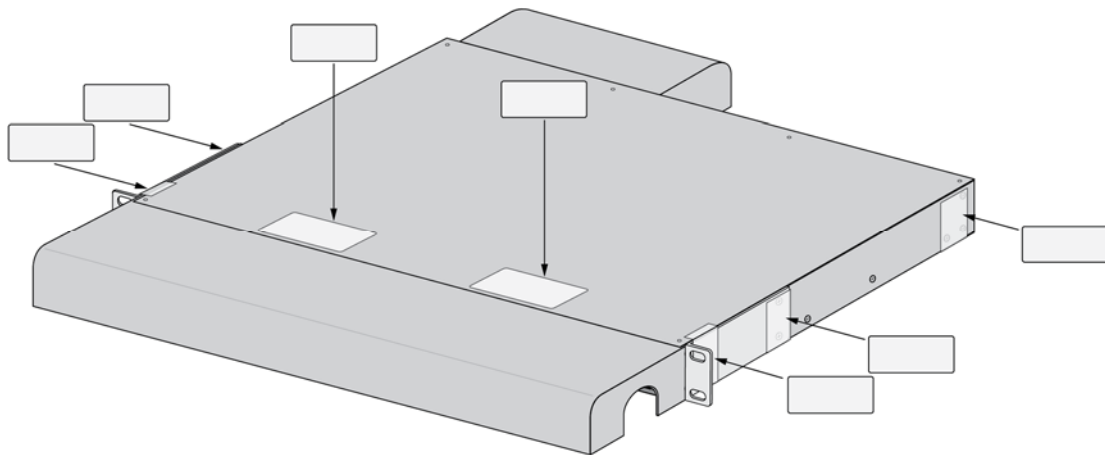

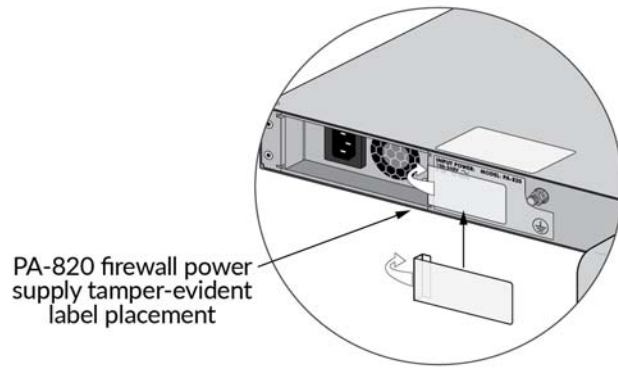
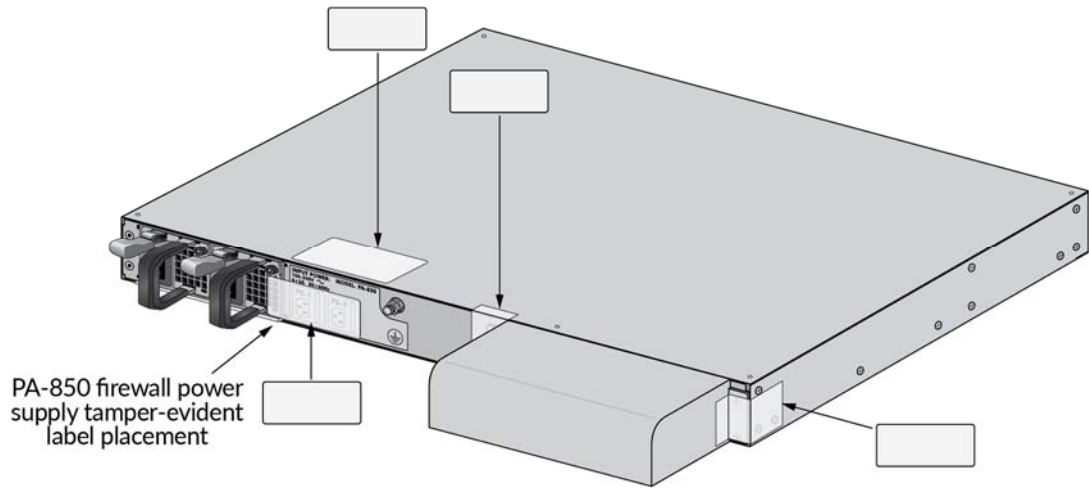

## Appendix E - PA-3020 and PA-3050 - FIPS Accessories/Tamper Seal Installation (7 Seals)

1. Install the front panel with the curve side up and line it up to the left and right side ear mounting holes.

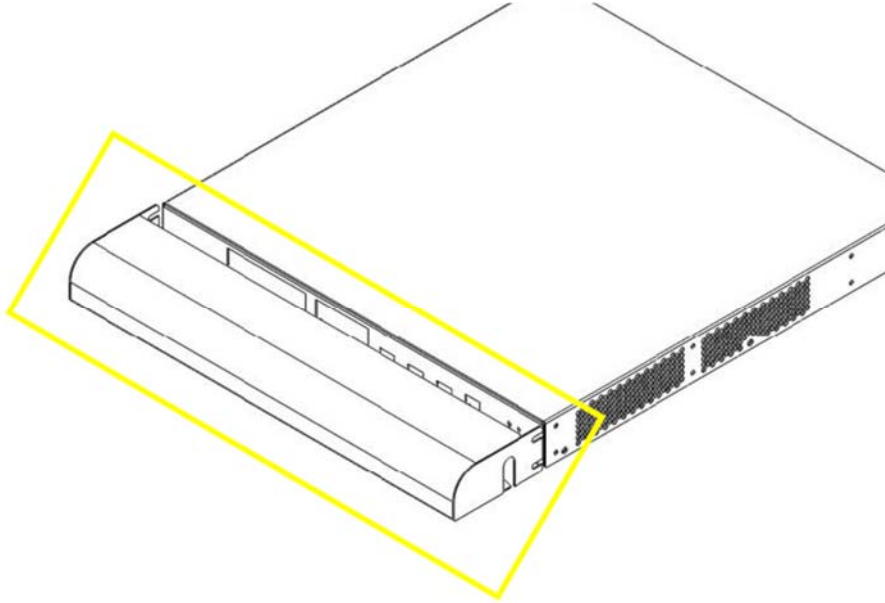

2. Install and secure the right side mounting ear and (2x) 6-32x1/2" screws provided in the kit. Repeat the same step on the left side of the chassis.

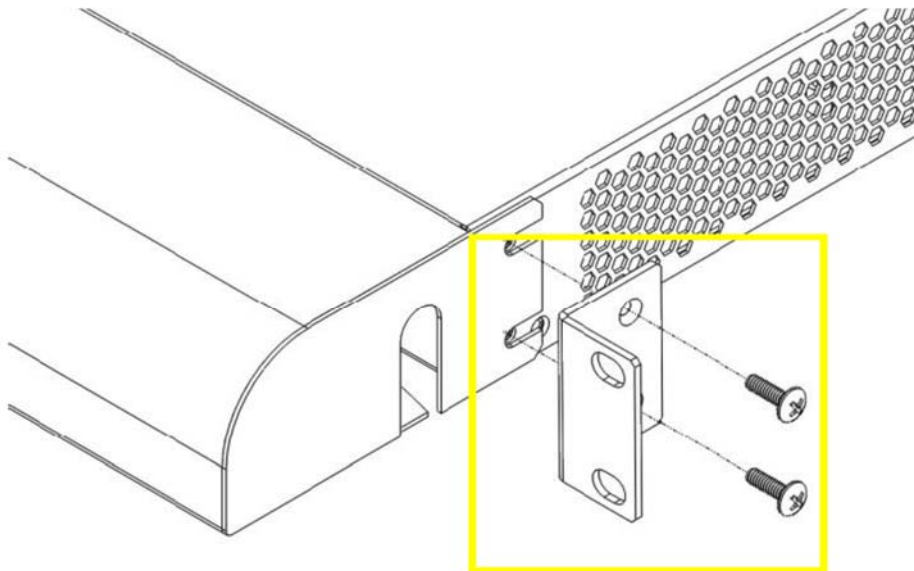

3. Install the right side FIPS plenum and secure with (4x) #6-32x1" SEM screws provided by the kit. Repeat the same steps for the left side.

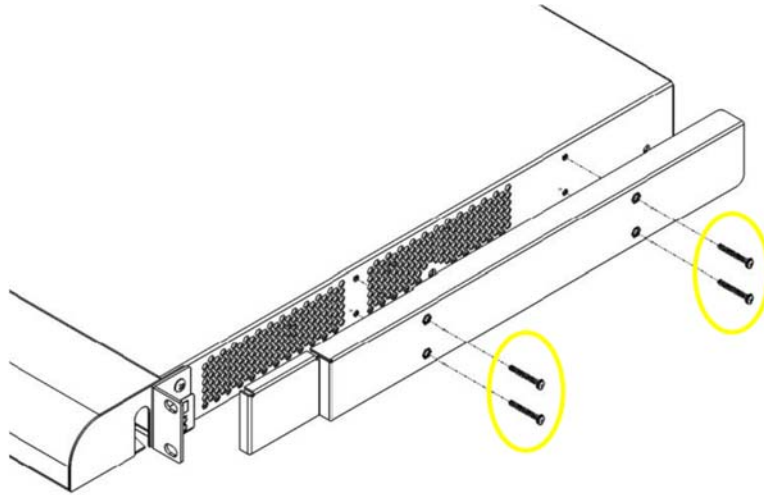

4. Affix a tamper seal to cover the right side bottom ear mounting bracket screw. Repeat the same steps for the left side.  
Affix a tamper seal at right side of the chassis between the top cover and the FIPS plenum.  
Affix another tamper seal between the bottom of the chassis and the FIPS plenum. Repeat the same steps for the left side.

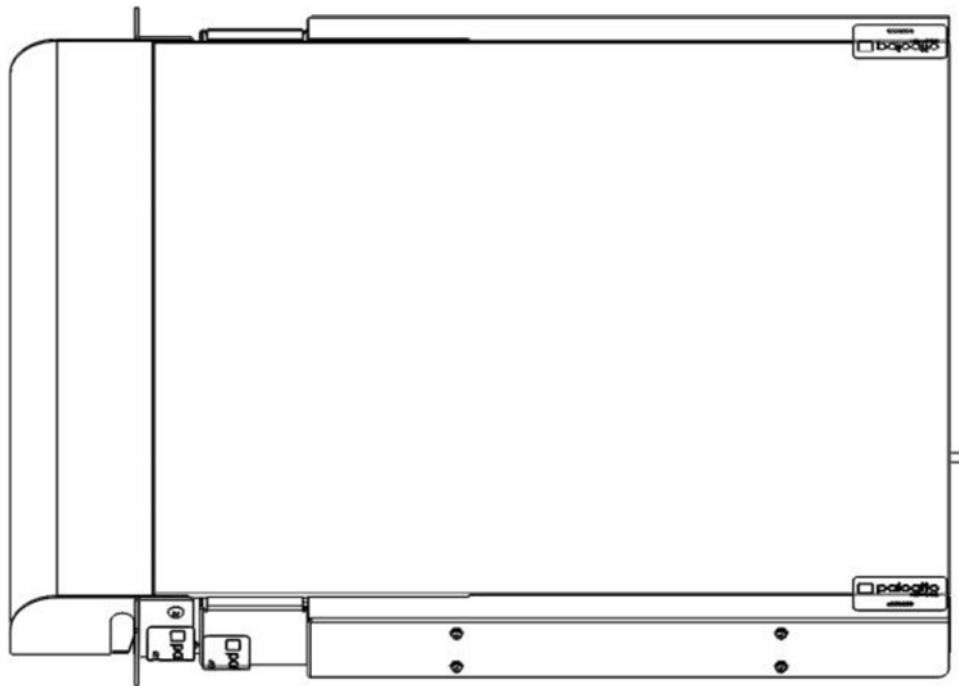

5. Affix a tamper seal on top of the cover / panel.

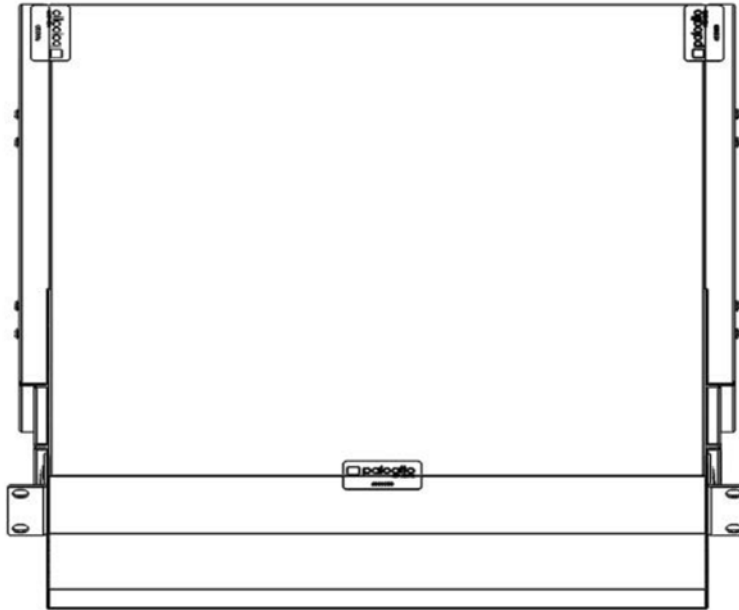

## Appendix F - PA-3060 - FIPS Accessories/Tamper Seal Installation (8 Seals)

1. From the front of the PA-3060, attach the Left and Right Front Cover brackets using the screws provided.

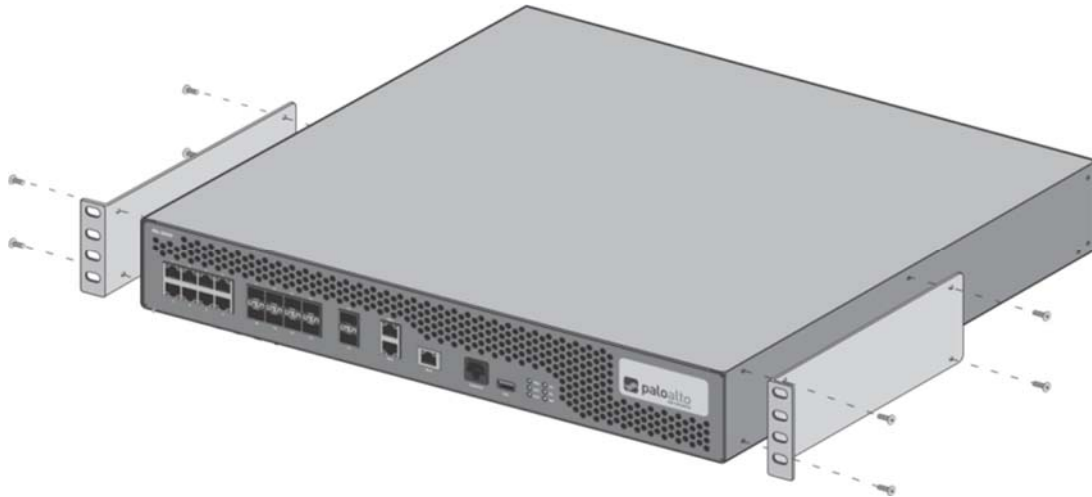

2. Attach Front cover to the front of the PA-3060 using the brackets and the supplied bolts and nuts. Ensure the gap in the cover is positioned below the networking interfaces.

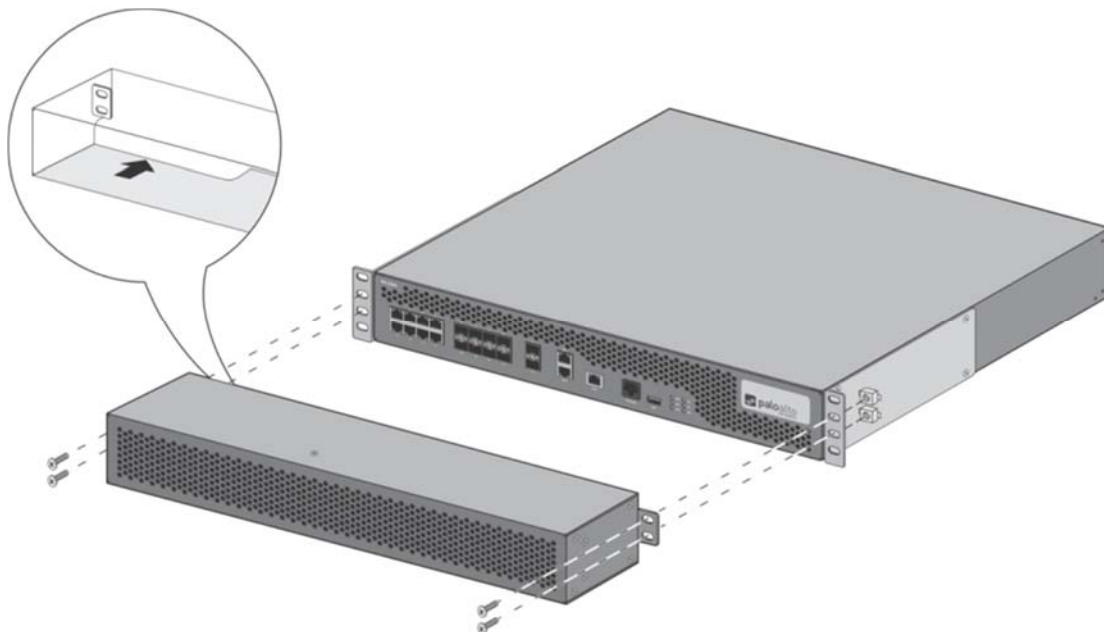

3. Attach Rear Cover to the rear of the PA-3060. Ensure the gap in the cover is positioned below the power supplies.

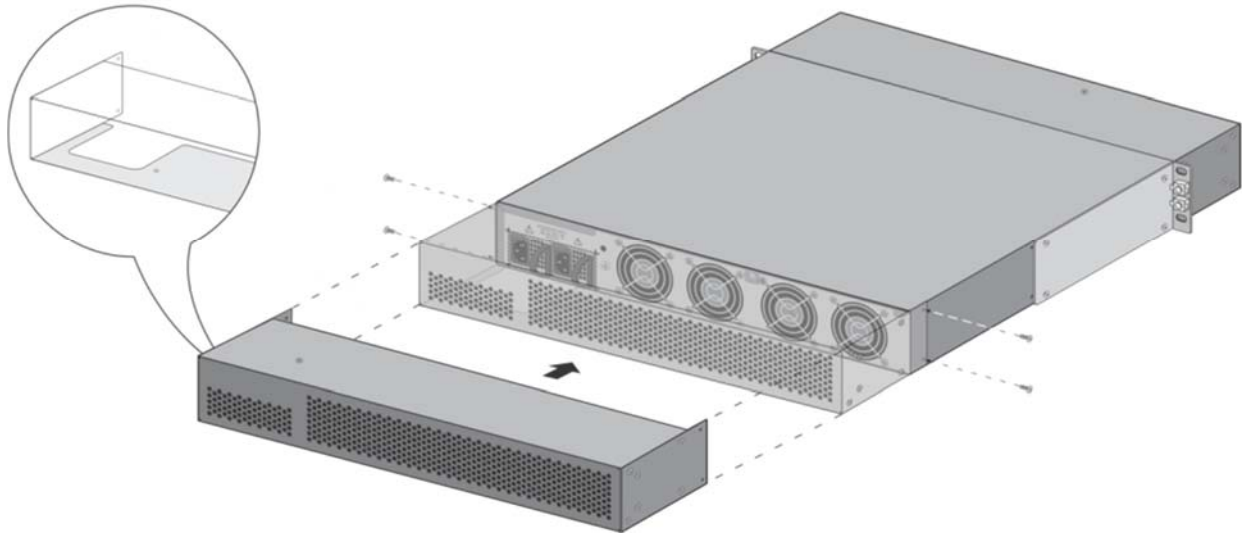

4. Affix tamper evident labels as follows.
  - A. Attach a tamper label to the top of the module overlapping the front opacity shield and the PA-3060.
  - B. Attach three (3) labels to the right side of the PA-3060 covering each screw used to attach the front bracket and rear opacity cover.
  - C. Attach three (3) labels to the left side of the PA-3060 covering each screw used to attach the front bracket and rear opacity cover.

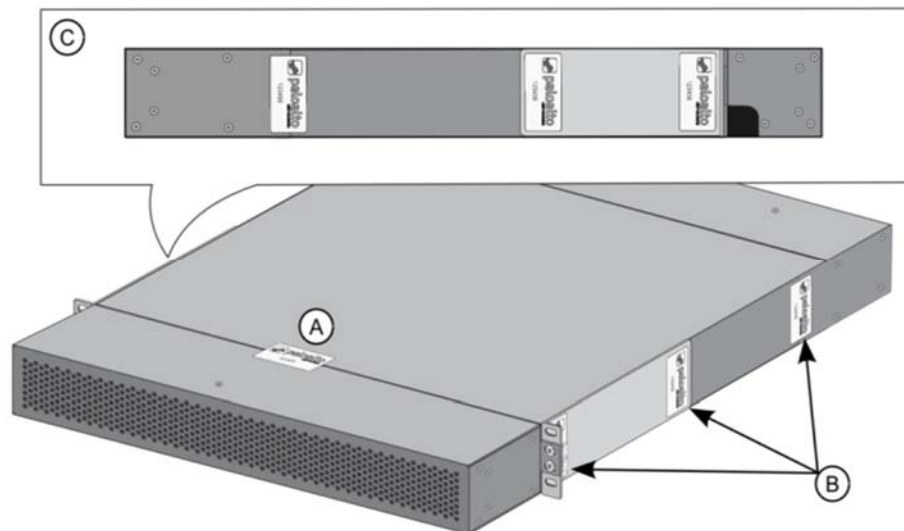

5. Viewing the bottom of the PA-3060.
  - D. Attach a tamper label overlapping the front opacity shield and the PA-3060.

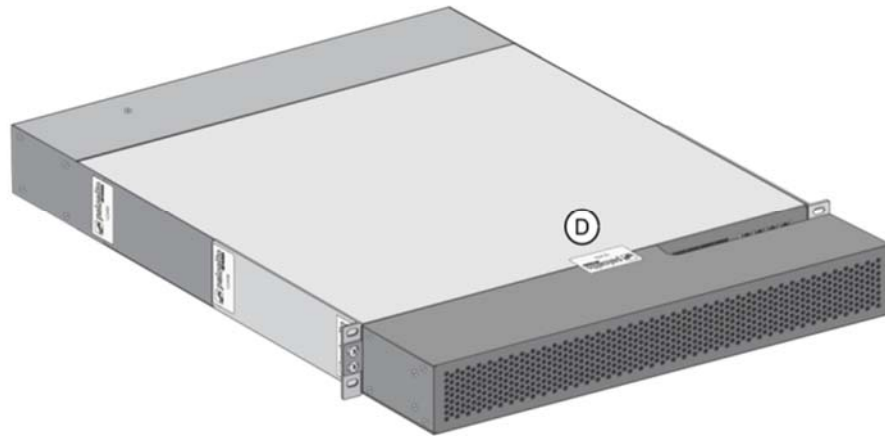



## Appendix G - PA-5000 Series - FIPS Accessories/Tamper Seal Installation (17 Seals)

1. Install the front panel.

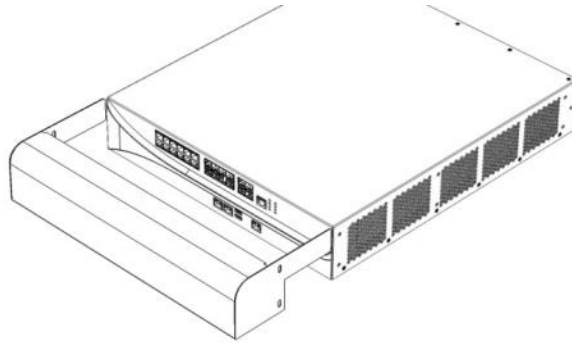

2. Install the right FIPS mounting bracket and secure with (2x) #8-32x3/8" screws provided in the original accessory kit. Repeat for the left mounting bracket.

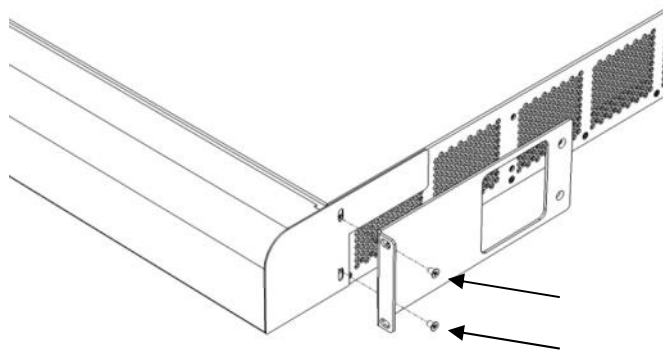

3. Install the side panel on the right side of the chassis and secure with (4x) #8-32x1.00"L screws. Place the leading edge towards front of the chassis. Repeat for the left side of the chassis.

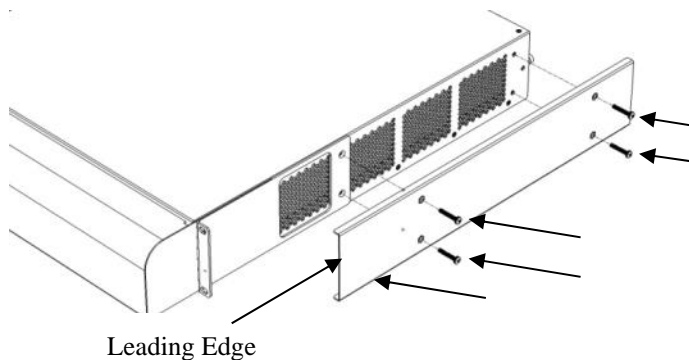

4. Affix two tamper evident labels over both upper and lower screws on the FIPS mounting bracket. Repeat for the left side panel.

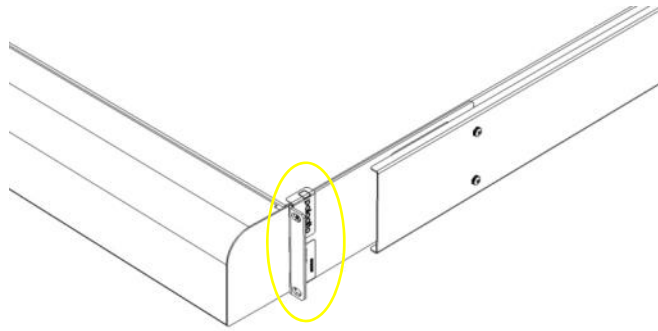

5. Affix two tamper evident labels over front upper and rear lower of the right side panel screws. Repeat for the left side panel.

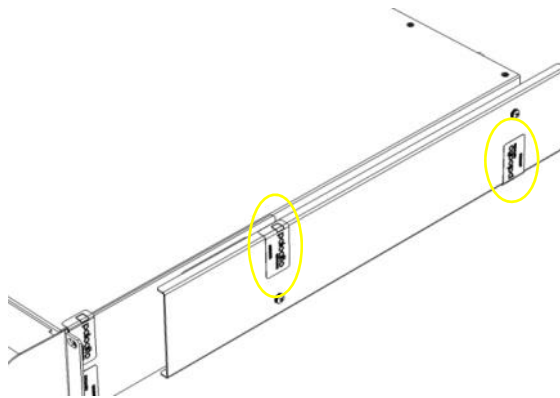

6. Affix three tamper evident labels on the top cover /rear chassis. Ensure the top cover screws are covered by the labels.

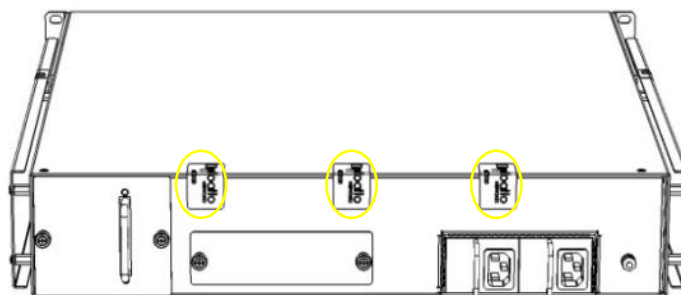

- Affix a tamper evident label on the top cover/fan access panel.  
Affix another tamper evident label on the bottom chassis/fan access panel.

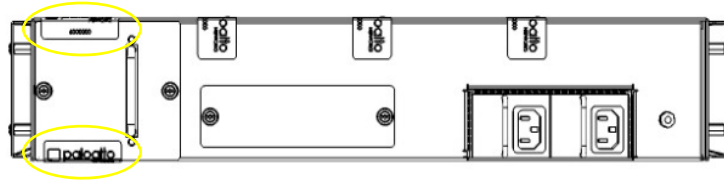

- Affix a tamper evident label on upper HDD access panel/rear chassis.  
Affix a tamper evident label on lower HDD access panel/rear chassis.

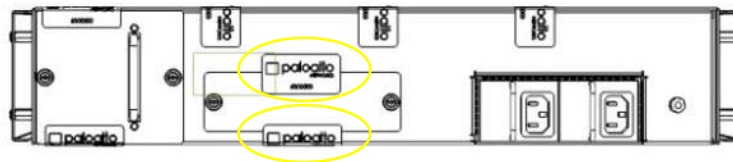

- Affix a tamper evident label on the upper left PSU/rear chassis.  
Affix a tamper evident label on the upper right PSU/rear chassis.

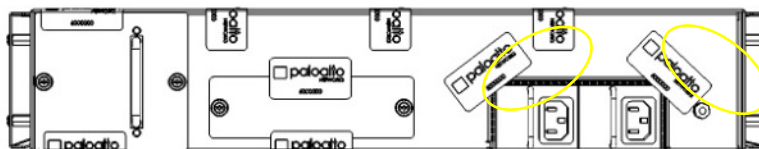

## Appendix H - PA-5200- FIPS Accessories/Tamper Seal Installation (28 Seals)

1. Place the firewall upside down on a flat Electrostatic Discharge (ESD) protected surface and ground yourself by touching a metal surface on the firewall.
2. Install power cables: plug the power cords in to the power inlets located on the back of the firewall and connect the ground lug and ground cable to the ground lug bolts (you cannot access these back ports after you attach the FIPS back cover).
3. Place the FIPS back cover onto the back of the firewall and attach it to the firewall using four #8-32 x 1/4" screws (two screws on each side of the cover). Route the power cables through the back-cover cable-guide openings.

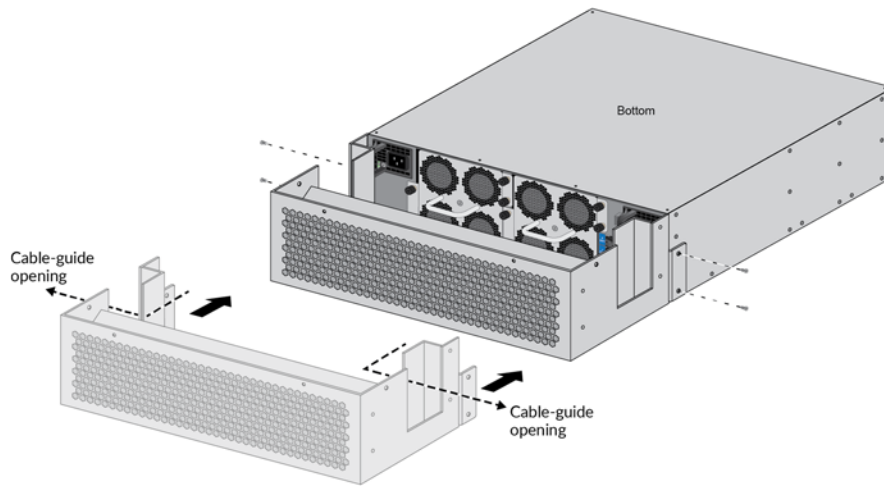

4. Attach the FIPS back-cover panel to the FIPS back cover using four #4-40 x 1/4" screws (one screw on each side of the cover and two screws on the back of the cover).

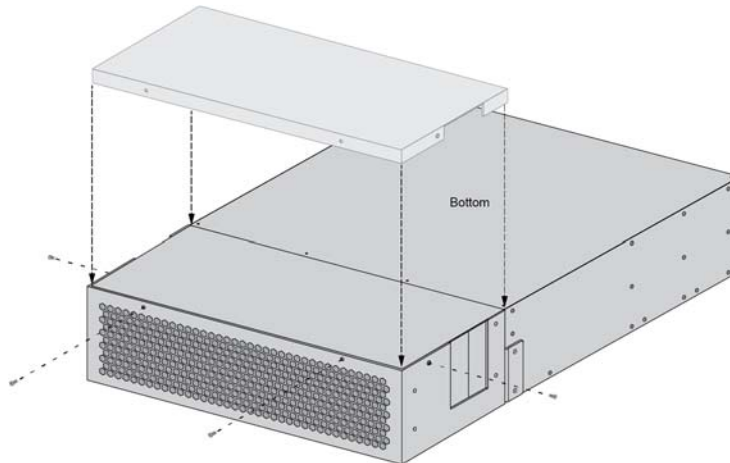

- Place the FIPS front cover onto the front of the firewall and place the rack-mount brackets over the holes on the front cover. Attach the front cover and rack-mount brackets to the firewall using eighteen #8-32 x 5/16" screws (shipped with the firewall)—use nine screws on each side.

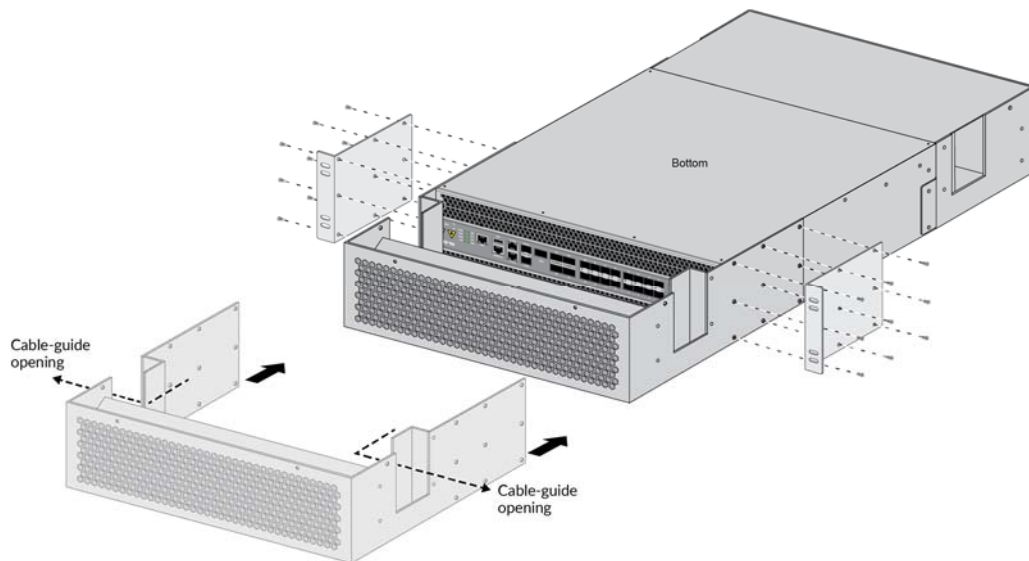

- Apply a tamper-evident label to each location shown in the illustrations (28 labels).

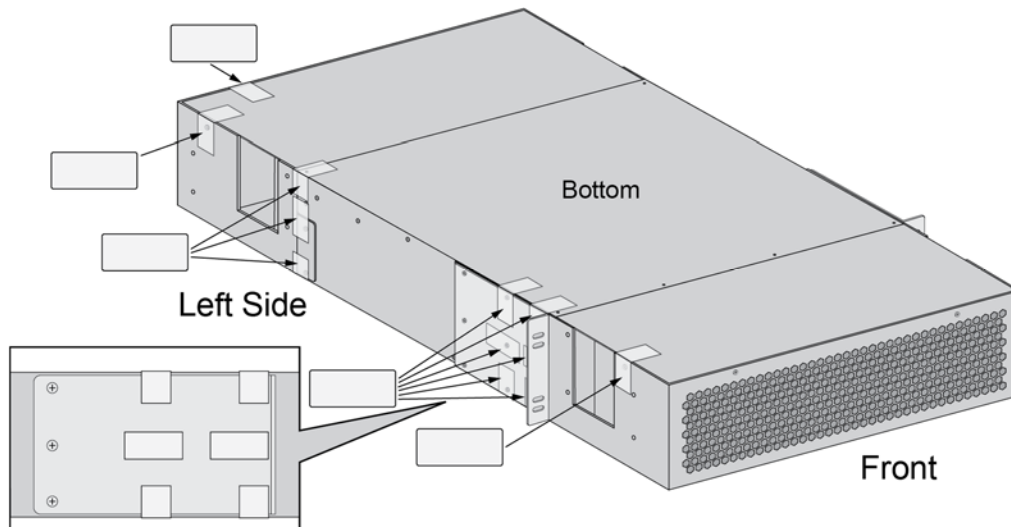

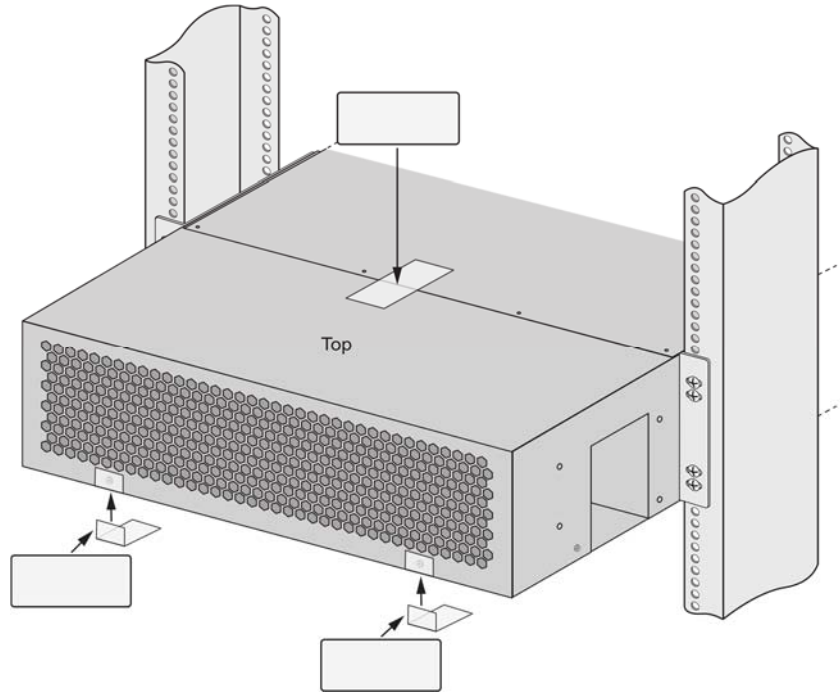
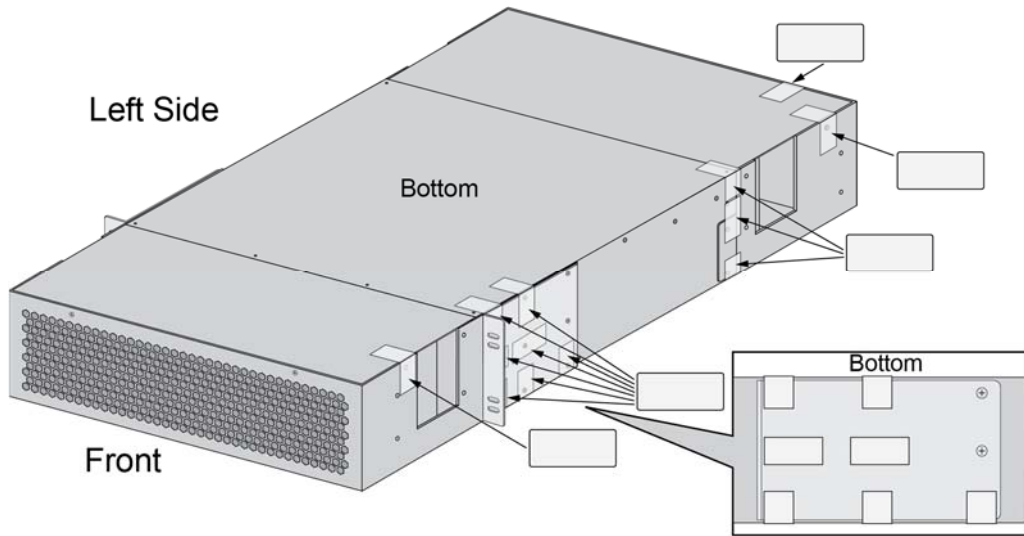

## Appendix I - PA-7050 - FIPS Accessories/Tamper Seal Installation (24 Seals)

1. Attach front right rack mount brackets in 4-post rack position. Do not attach rear rack mount brackets. Note that brackets are rotated 180 degrees, so the screw holes lineup and the rack mount holes are now on the front of the chassis.

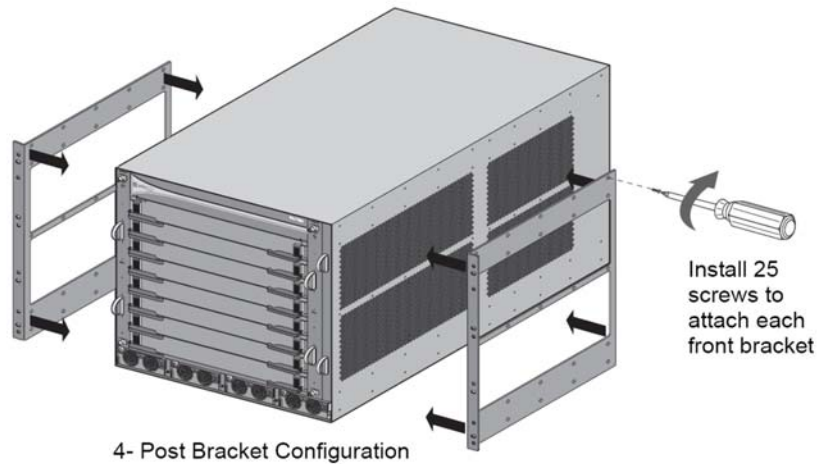

2. Align right plenum bracket with 5 open screw holes. Attach air plenum brackets using 5 of the remaining bracket screws as shown. Repeat for left side.

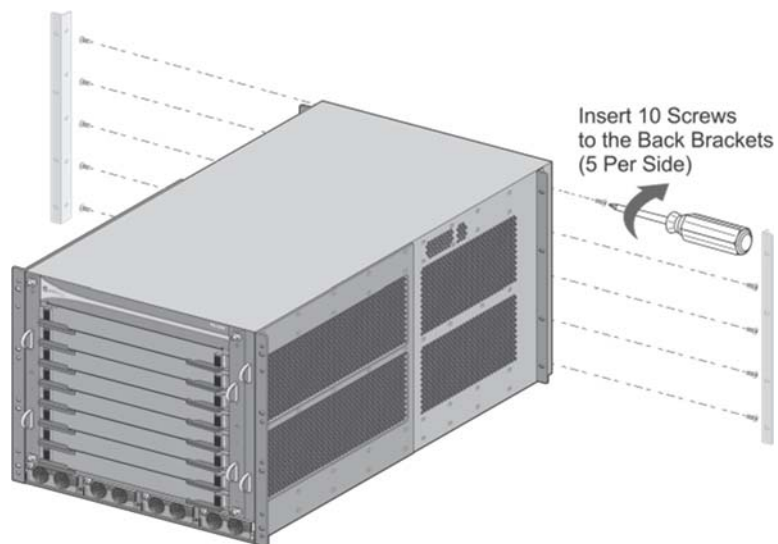

3. Attach bottom plenum to the front right rack mount bracket. Place only the middle two screws.

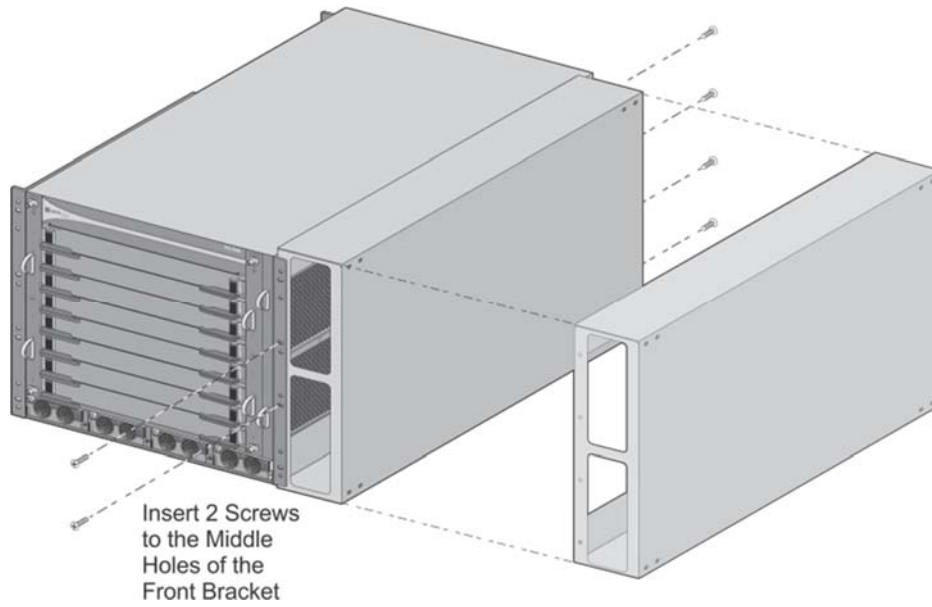

4. Attach the bottom plenum to the rearward right plenum bracket.

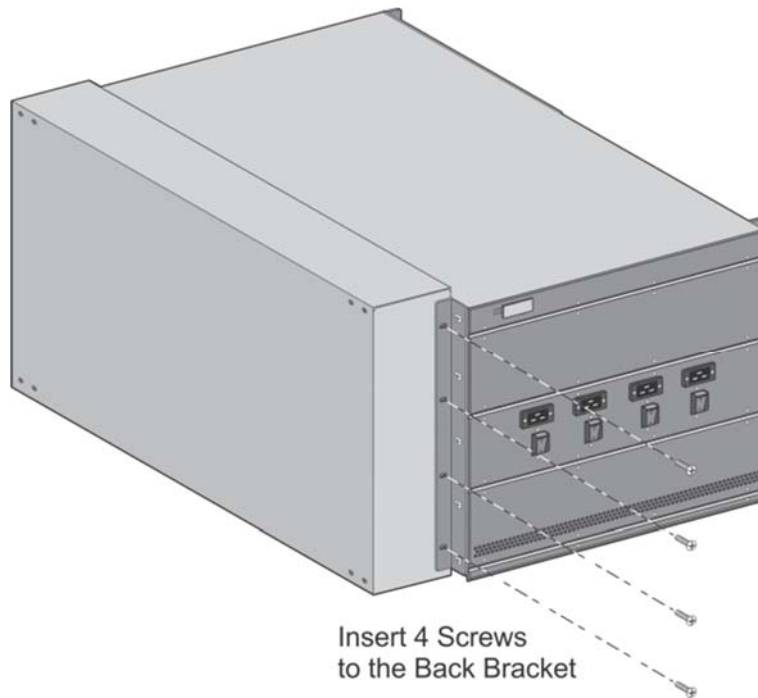



5. Rotate PA-7050 chassis clockwise 90 degrees onto the bottom plenum.

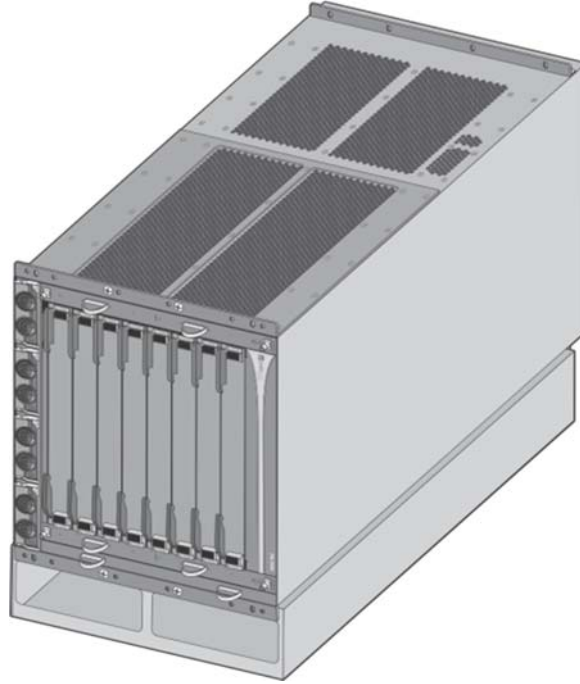

6. Assemble top plenum and cable guide hardware.

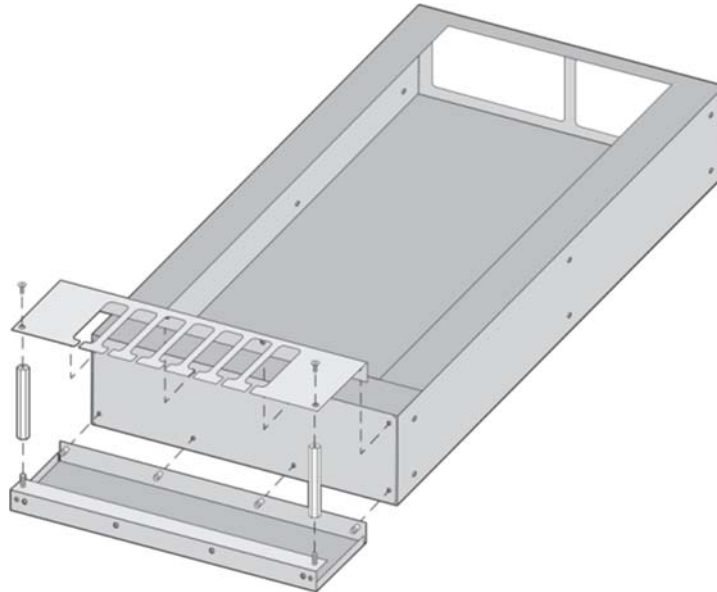

7. Attach top plenum to the front left rack mount bracket

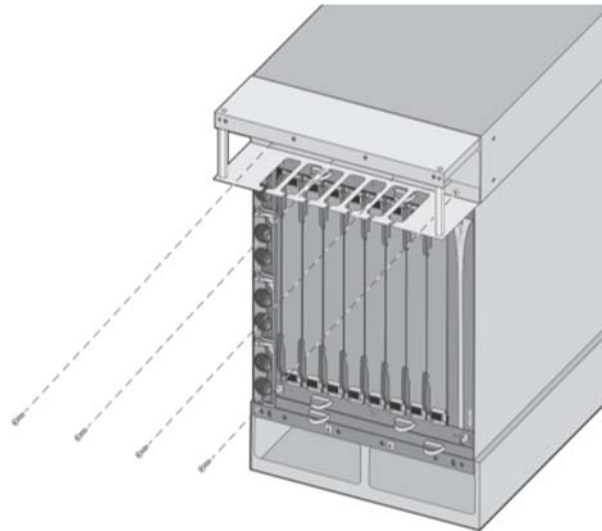

8. Attach front opacity shield using the four captive screws

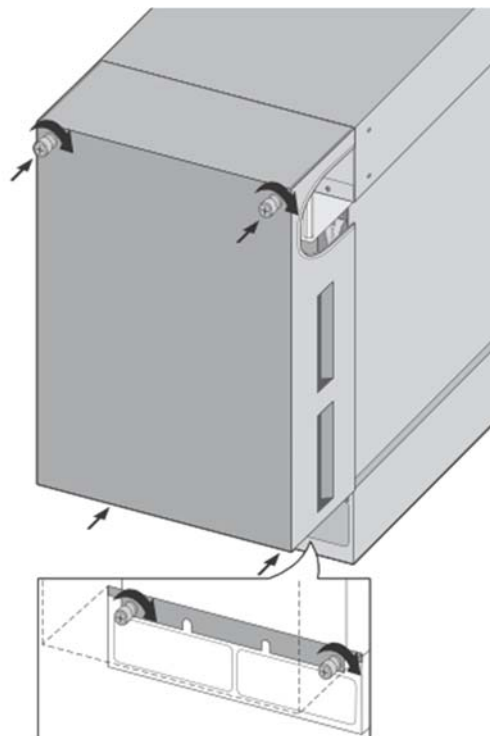

9. Attach top plenum to the rearward left plenum bracket along with plenum's rear opacity shield as shown

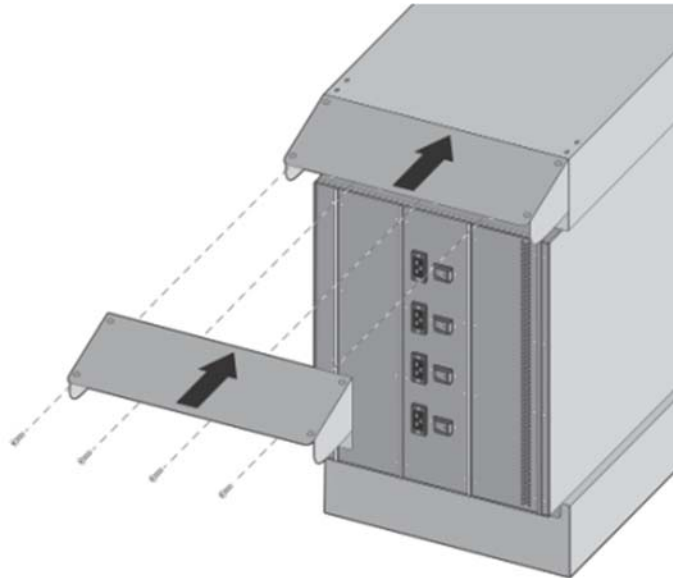

10. Loosen four screws on the panel containing the power supply vent. Insert the power supply vent opacity shield and tighten screws.

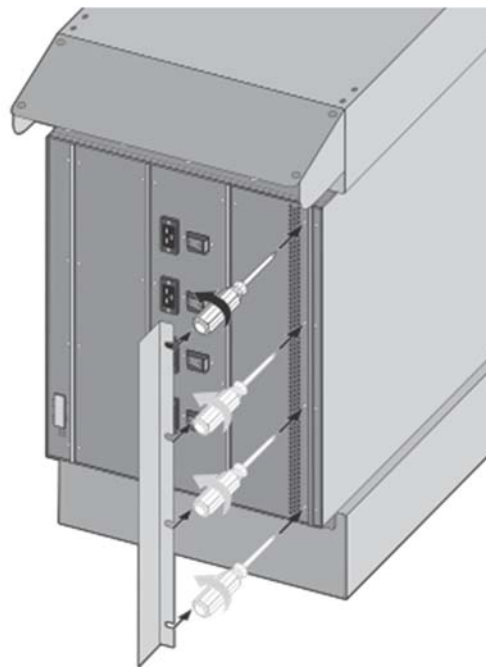

11. Facing the front of the module, affix two (2) labels to top of the front opacity shield, one near left edge and one near the right edge. Ensure the labels, when placed, overlap onto the top of the plenum, as shown. (2 total)

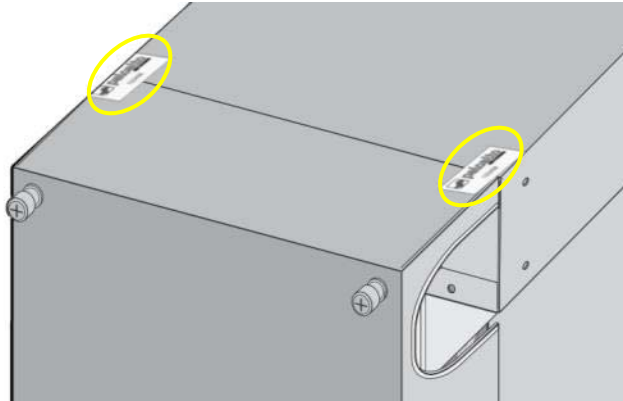

12. Facing the front of the module affix one (1) label centered to the bottom of the front opacity shield to the bottom air plenum, as shown. (1 total)

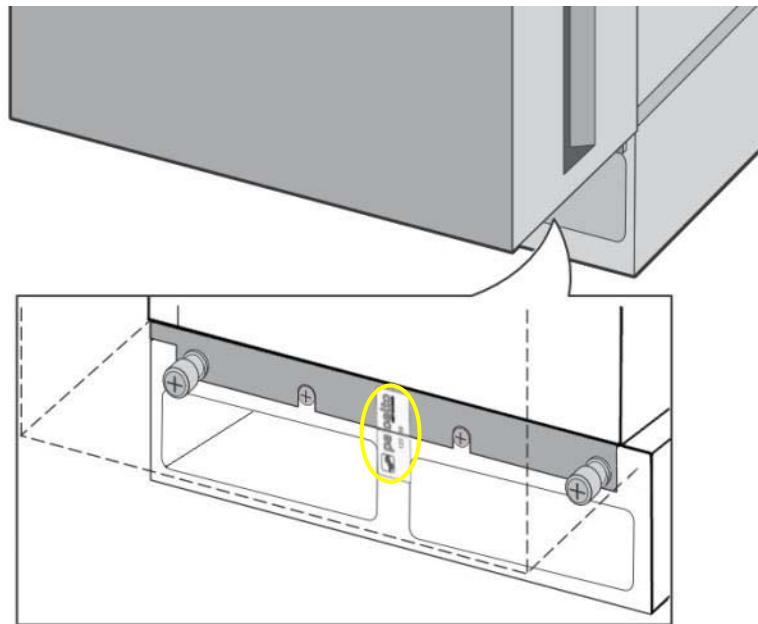

13. Facing the rear of the module, affix two (2) labels to top of the rear opacity shield, one near left edge and one near the right edge. Ensure the labels, when placed, overlap onto the top of the plenum, as shown.  
(2 total)

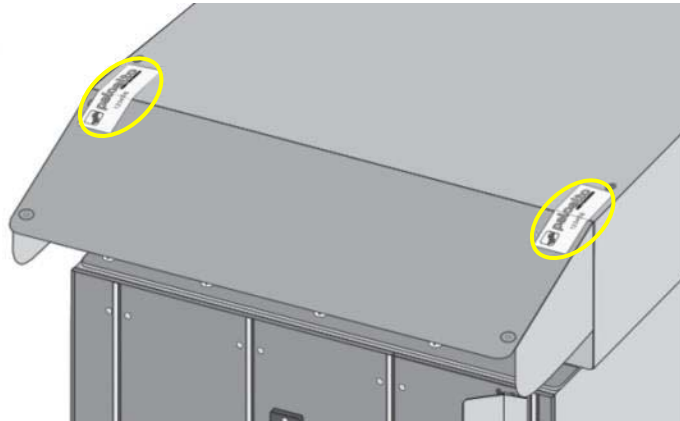

## 14. Facing the rear of the module;

- A. Affix one (1) label to the top plenum/opacity shield, covering the left and right outermost screws, as shown.
- B. Affix one (1) label to the left and right edge of the top plenum bracket folding over the outer edge of the module, as shown.
- C. Affix one (1) label to the top of each rear panel (3 panels). Ensure that the labels lap onto the top rear plenum brackets, as shown.

(7 total)

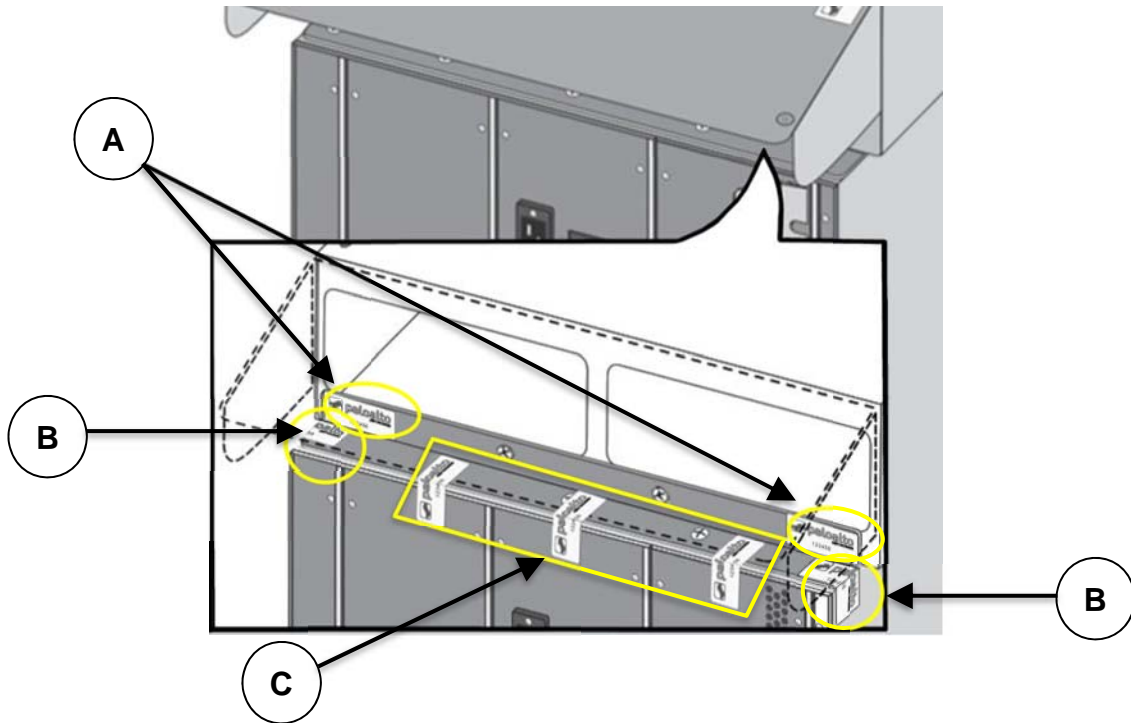

15. Facing the rear of the module,
- Affix one (1) label to the bottom of each rear panel (3 panels). Ensure that the labels lap onto the bottom rear plenum brackets, as shown.
  - Affix one (1) label to the left and right edge of the bottom plenum bracket folding over the outer edge of the module, as shown.
  - Affix one (1) label to the bottom plenum's rear side and the bottom plenum rear bracket.

(6 total)

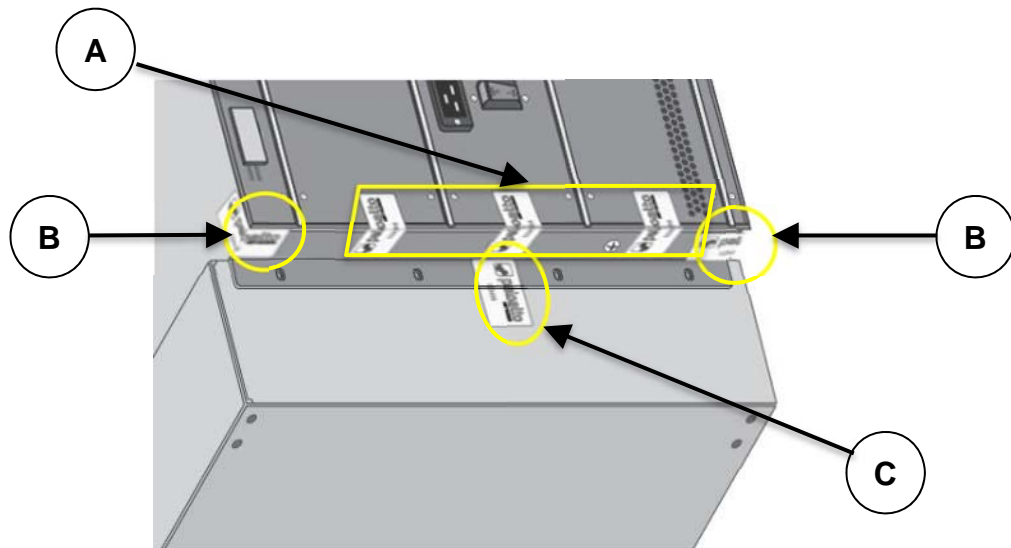

16. Facing the rear of the module;

- Affix one (1) label to cover one screw for each power switch, as shown.
- Affix one (1) label to the top and bottom of the vent opacity shield, as shown. Please ensure that the captive screw is covered.

(6 total)

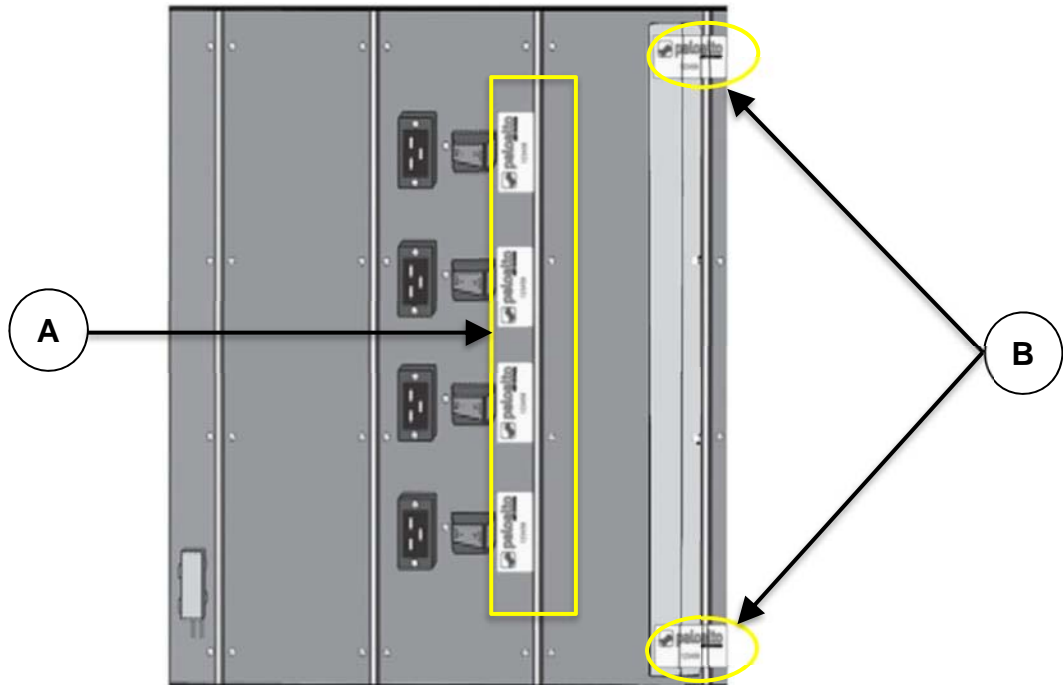



## Appendix J - PA-7080 - FIPS Accessories/Tamper Seal Installation (10 Seals)

1. Using the supplied screws attach the Cable Manger Kit with upper opacity lip to the front of the PA-7080, as shown.

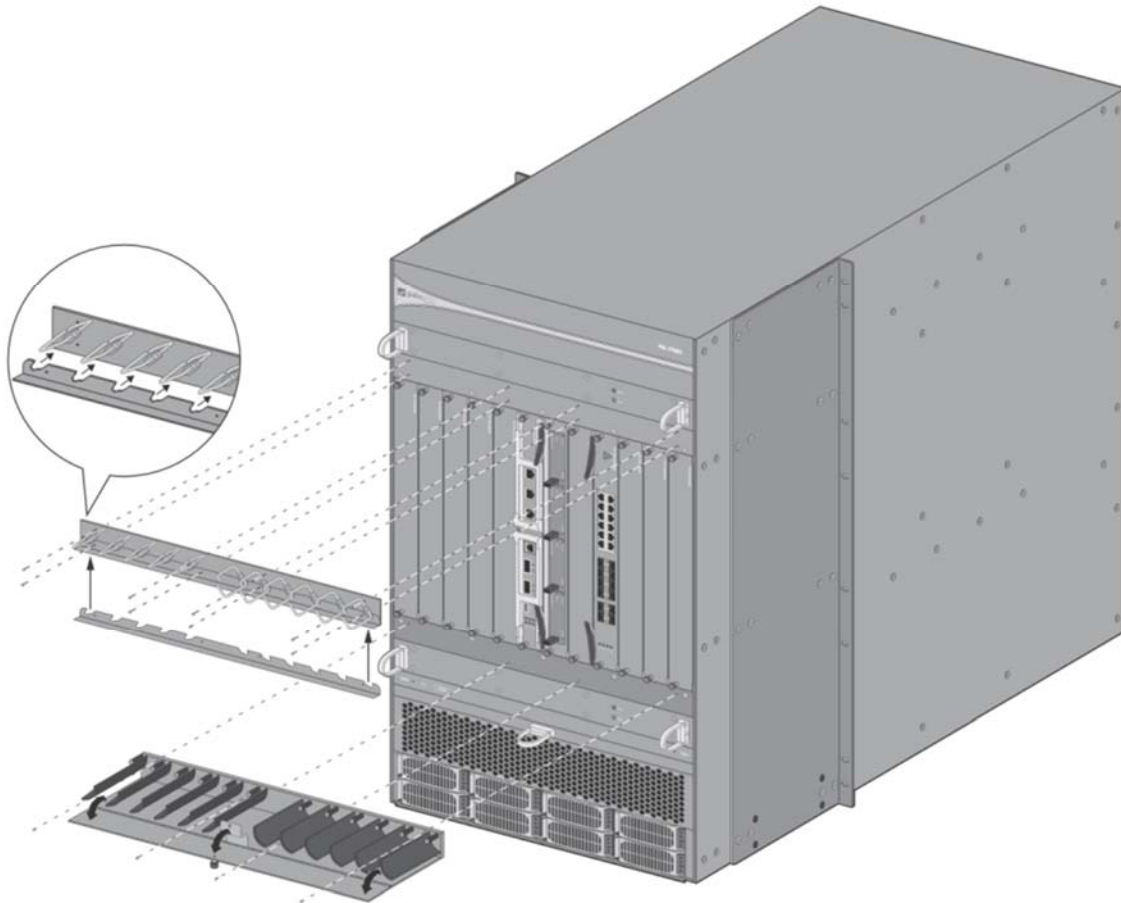

- Using the supplied screws, attach the Left and Right Front Cover brackets to the sides of the PA-7080, as shown.

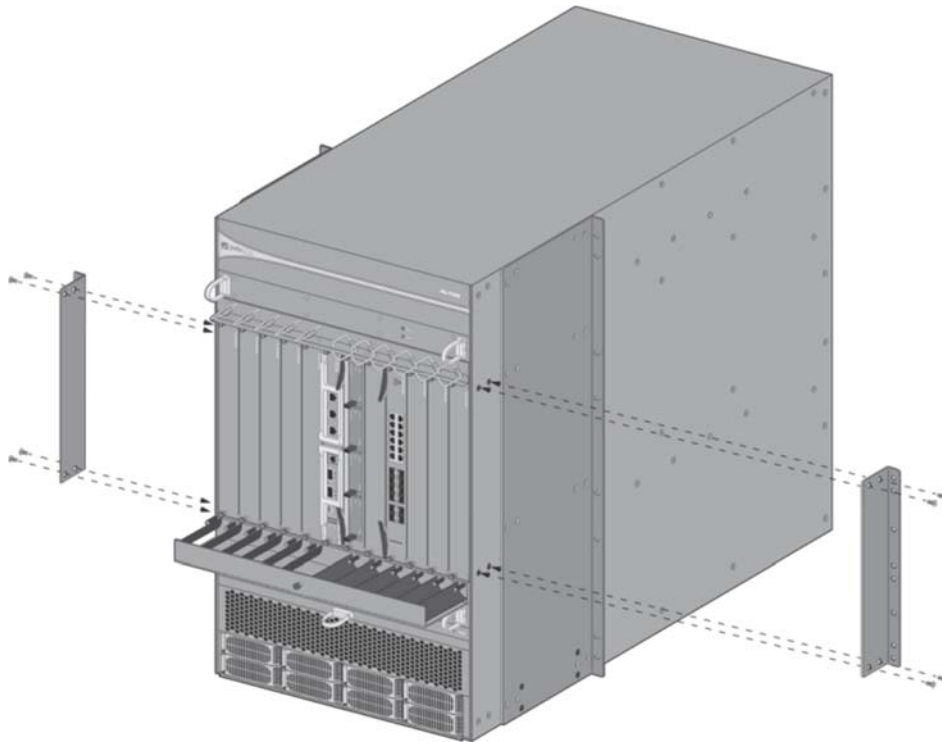

- Using the supplied screws attach front opacity shield to the PA-7080 as shown.

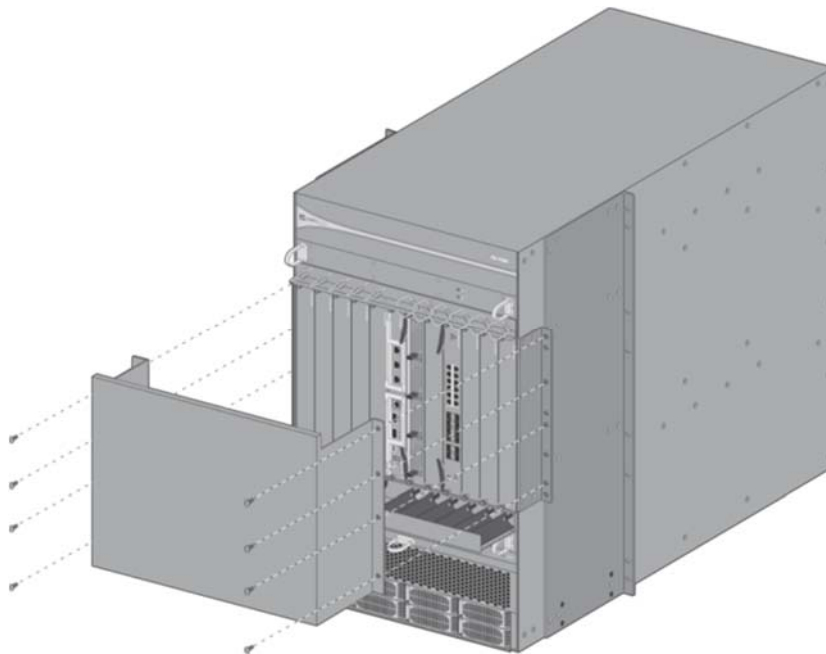

4. The final assembly for the PA-7080 with the FIPS kit is as shown.

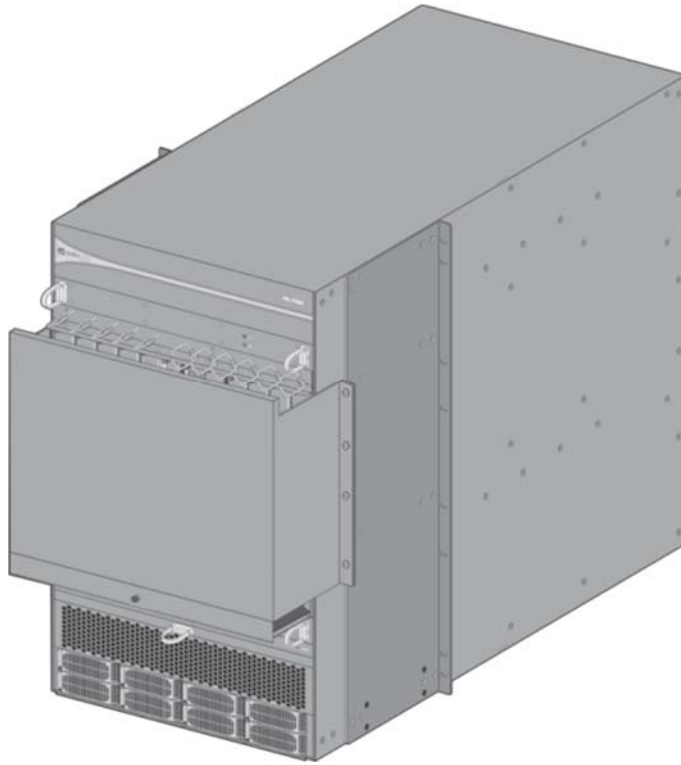

5. Facing the front of the PA-7080:
  - A. Affix one (1) label to the front and center of the exhaust fan tray. Ensure the label overlaps the seam with the front PA-7080 branding panel as shown. (1 total)
  - B. Affix one (1) label to the left and right outer edge of mounting flanges for the front opacity shield. Labels should fold over the edge of the cover flange and mounting bracket onto the side of the PA-7080. (2 total)
  - C. Affix one (1) label to the front and center of the air intake fan tray. Ensure the label overlaps the seam with the PA-7080 electrostatic discharge port panel as shown. (1 total)

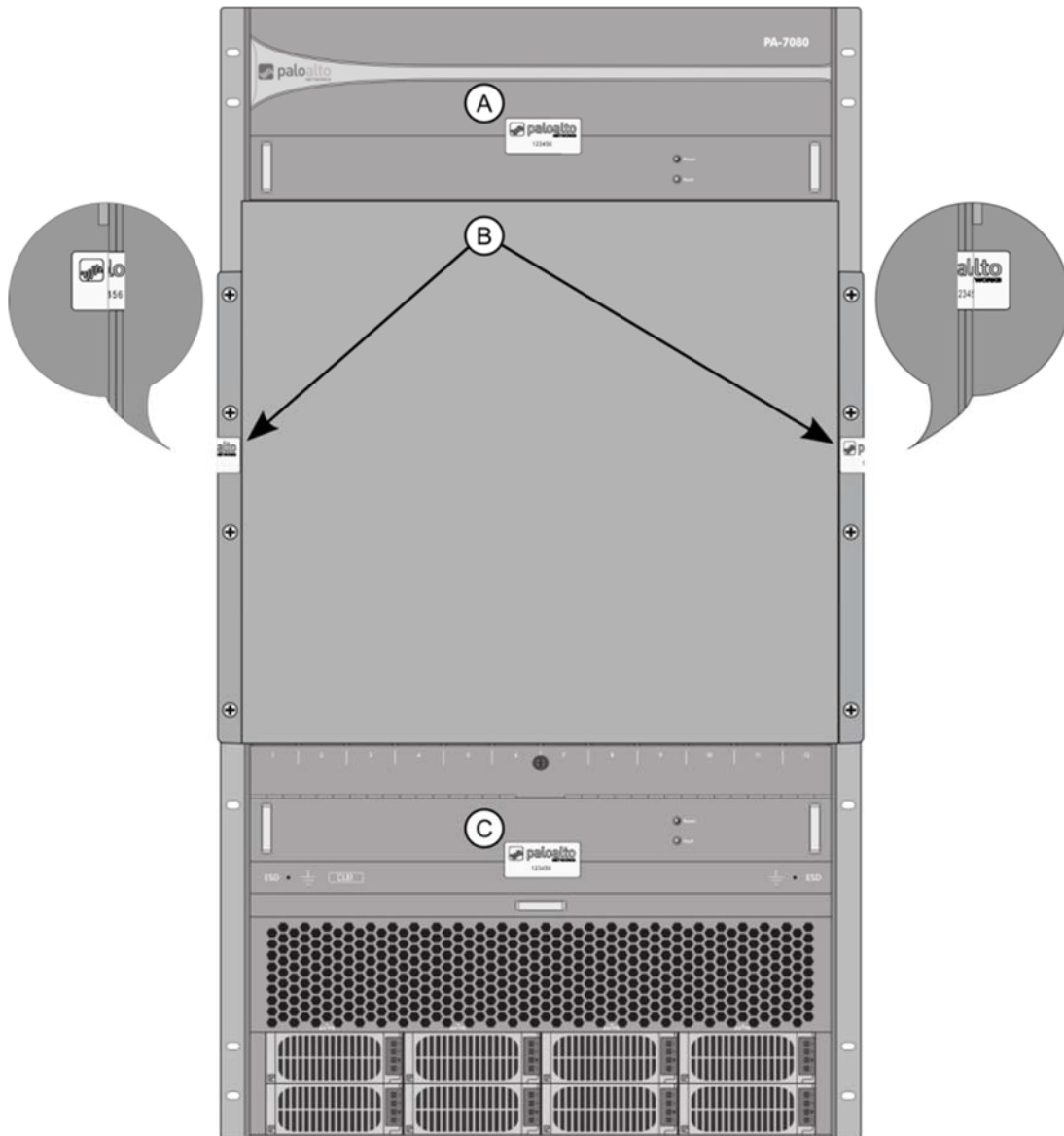

6. Facing the rear of the PA-7080;
  - D. Affix one (1) label to the left and right outer edge of the upper back panel. Labels should be placed just below the rear exhaust vent as shown. Labels should wrap around onto the sides of the PA-7080 (2 total).
  - E. Affix one (1) label to the left and right outer edges of each power entry module as shown. Labels should wrap around onto the sides of the PA-7080 (4 total).

