



AMIA Tech Review

From the Association of Moving Image Archivists



Welcome to the AMIA Tech Review

Welcome to the first issue of the AMIA Tech Review! This publication is the product of our belief that this field needs a timely technical review oriented to those things new and old which will or have already impacted our work. Well, here it is! [MORE ▶](#)



The Problem of the Inside Out Tee Shirts

There are many, many questions that arise about man's place in the universe, and what kinds of dark forces lurk therein. [MORE ▶](#)

FEATURES



Traditional negative cutting for commercial feature films doesn't exist any more... and I don't miss it at all! [MORE ▶](#)

Negative Cutting in the Age of Digital Intermediates



Not every piece of data is worth having three copies. Indeed the cost of storing, maintaining, and migrating three copies of each digital asset can turn out to be quite a pricey endeavor. [MORE ▶](#)

The Digital Nightmare: Practices to Future-Proof Your Digital Content

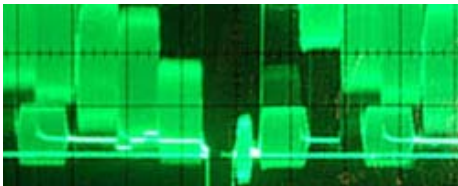

The transfer of the "Everly Brothers Shows" to Digital Betacam from Ampex Type A tapes turned out to be a challenge to say the least. [MORE ▶](#)

Type A and The Everly Brothers Show

APRIL, 2010: VOL 1

CONTRIBUTING AUTHORS

Chris Lane
Mo Henry
John Menke
Ralph Sargent
Al Sturm

UPCOMING EVENTS [Click for Details](#)

April 10-15	NAB Trade Show
May 2-9	FIAC Congress
May 3-5	JTS 2010: Oslo
May 19-22	ARSC Conference
May 21-23	AES Conference
June 3-7	SEAPAVAA Conference
August 10-15	IFLA Conference
August 12-14	The Reel Thing XXV
October 4-8	ACVL Conference
October 15-18	FIAT Conference
October 26-28	SMPTE Tech Conference

AMIA/IASA Joint Conference
November 2-6, 2010



Welcome to the AMIA Tech Review!

by Ralph Sargent

Welcome to the first issue of the AMIA Tech Review! This publication is the product of our belief that this field needs a timely technical review oriented to those things new and old which will or have already impacted our work. Well, here it is!

70 years ago RCA, the Radio Corporation of America, began publishing a quarterly they called the "RCA REVIEW – a technical journal." Its purpose was to alert interested readers and RCA's many employees scattered around the globe to new advances on which the company was working. Over the years, the topics covered were amazingly varied, for example: the application of microwaves to the purification of penicillin, walkie-talky communications for television floor managers, new circuits for radio and television receivers and transmitters, current and future electron microscope designs, developments in microphone design, RADAR and so on. Nothing was sacred or held back from publication unless in the public's interest to do so (such as winning WW2.)

While RCA's Review presents us a model in how we might conceptualize the AMIA Tech Review, there is one twist. **We** have to pay attention not only to the future but also very much to the past.

We are at this very moment witnesses to the passing of analog methods which performed and supported our work as restoration, archive and storage experts. But watching analog recede into the vague halls of memory will do us no good unless we can thoroughly document the "how's" and "why's" of techniques used in the past and, where necessary, reproduce them. I do not need to emphasize how many thousands of hours of film, videotape and audio recordings we each hold and must be able to play now and in the future! The very machinery that reproduces these recordings must either be stored or supported with documents of their construction, the standards to which they must adhere or in many cases the very tools and jigs needed to build them, if need be. For example, without a videotape player that matches the format of your recordings how would you expect to play them? Can you always rely on outside services to support obsolete formats? Do you truly believe that at any given moment you are getting the very best reproduction of images and sounds you treasure?

(In other words, should you keep the source material for a **future** transfer or toss it away after the **present** transfer is made?) Is there a possibility that at sometime in the future a given reproduction device can be made even better than what we have now? Are you the type of person who likes to solve problems rather than stand around whining that such and such will never get done because you don't know how or where to turn?

Technology questions of today, tomorrow and yesterday will all be fodder for the "AMIA Tech Review."

The Editorial Board of the Review represents a wide cross-section of expertise in the field and we will look to them not only to provide editorial advice and commentary on articles submitted by others, but also to produce their own contributions for publication. Feel free to contact us to offer your views, questions and articles (please see below.) Our brief is to keep you informed, interested and awake. Speak up!

* * * * *

A few notes on our plans: We expect to publish the AMIA Tech Review at least three times per year. Content will come from our readers and invited guests. Those of you who feel you have appropriate material to contribute, please feel free to advise us via a thematic proposal or précis of your article. If accepted for publication, your articles should be received at the AMIA office no later than six weeks prior to next publication date. All articles or suggestions submitted are subject to review, condensation or augmentation and editing.

Publication of the AMIA Tech Review will be web-based in landscape format. Readers are encouraged to print from it whatever they wish **for their own use**; however, all material shall remain the copyrighted property of The Association of Moving Image Archivists or other copyright holders as indicated and may not be reproduced for any other use in any form without the prior express written permission of the Association or other copyright holder.

* * * * *

We encourage readers of the AMIA Tech Review to become members of ancillary trade associations such as the National Association of Broadcasters, the Audio Engineering Society, the Society of Television Engineers, the Society of Motion Picture and Television Engineers, etc. Cross-pollination of technical information is important and we strongly support it!

Finally, please let us know what you think. It never hurts to speak your mind in a civil and constructive manner. If there is some aspect of this publication you feel could be improved, please let us know. If there is something you liked, let us know. You get the idea....



Negative Cutting in the Age of Digital Intermediates

by Mo Henry

Traditional negative cutting for commercial feature films doesn't exist any more... and I don't miss it at all! I don't lay awake all night worrying about a miscut or any of those things which might have gone wrong. The job has changed completely! I used to say that my job was similar to how Woody Allen described flying: Hours of boredom interrupted by moments of terror. That's all gone now.

Now that Digital Intermediate (DI) is being used by almost everyone, we're taking full lab rolls straight from telecine and sending them to be scanned.

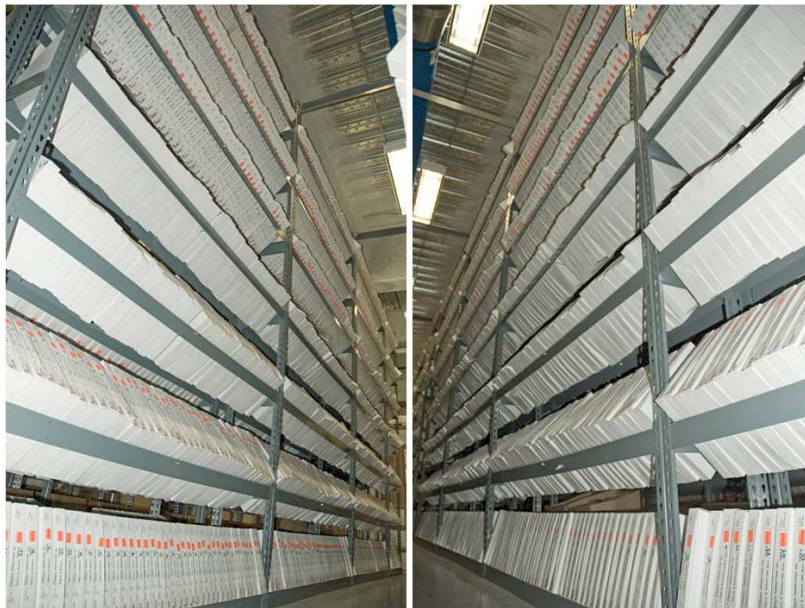

Above is a single feature that's in my vault right now and we've started archiving it. It's over a million feet of negative and the DI facility has pulled what it needed from most of those boxes – perhaps 10

frames from each (or more) – then put the film back in the box. It’s a tremendous amount of labor going through all of that.

But once a film has been completed, what do you do with the original camera negative? Grover Crisp of Sony Pictures Entertainment is actually the one who helped me come up with the idea of taking an old-fashioned approach to this. The idea was to do just as we always had done with cut negative, which was to separate the good takes from the rest of the footage we’ve traditionally called “trims and outs.” We would then hold the good takes in a separate place as *the* asset. Because of the DI scanning process, we’re not physically pulling shots out of the camera rolls for scanning and we wind up at the end of the post work with all of the original material intact. The question was: Do we send the film into storage the way it is or do we go through it and try to glean out the source material that was used for the actual scan? We decided that that was what we were going to do, (i.e. pull the actual shots that were used in the final film.)

So what happens after the DI is finished? I’m speaking of the completion of picture editing. The editor(s) send me the camera negative - probably the most of which is 85% (or more) outs. They also send me “Assemble Lists” of the exact shots that were scanned and used in the DI. We use those lists to go back to the original camera rolls and pull out the shots that were used. Sometimes it might be only one shot in 1000 feet; sometimes ten shots. It just depends on what the particular scene was and how it was photographed.

Once the shots are pulled we build them up in what is called “Event Order.” “Event Order” can be defined as how the shots appeared in the final edit as if you were watching it. There is a difference though: the shot is not cut down to just what you saw on screen, rather it is the entire “take”– the full shot from slate to slate. Finally, we build those shots into 1000 foot rolls which are “Machine Ready;” that is, they are hot spliced together and you could put them up on a scanner tomorrow.

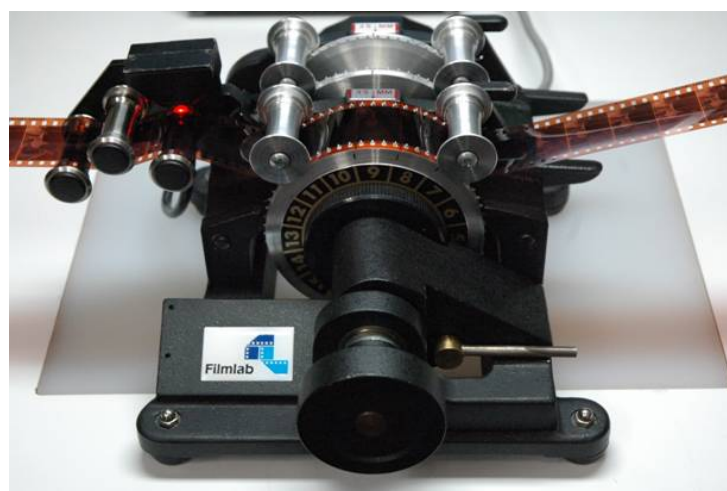

Data collection begins at this point. The “Machine Ready” rolls are put on a synchronizer equipped with a barcode reader, as shown above, which gathers shot-by-shot keycode information. Pretty boring stuff really, but if you’re going to go back and revisit a film this is how you’ll find what you need.

In	Out	E/Type	ENT	Duration	Mfr	St	Key In	Ir	Key Out	Ir	TC In	TC Out
0000+00	0002+15	35mm4perf	BCD	0003+00	??	??	00 0000 0000	-00	00 0000 0002	+15	01 01 29 02	01 01 30 00
0003+00	0016+14	35mm4perf	BCD	0013+15	Kodak	KI	01 8633 9950	-01	01 8633 9963	+13	01 01 30 00	01 01 38 23
0016+15	0050+06	35mm4perf	BCD	0033+08	Kodak	KI	01 8633 9708	-13	01 8633 9740	+10	01 01 38 23	01 02 00 09
0050+07	0064+03	35mm4perf	BCD	0013+13	Kodak	KI	01 8639 9687	-04	01 8639 9700	+08	01 02 00 09	01 02 09 05
0064+04	0113+08	35mm4perf	BCD	0049+05	Kodak	KI	01 8639 6237	-12	01 8639 6295	+08	01 02 09 05	01 02 40 19
0113+09	0124+09	35mm4perf	BCD	0011+01	Kodak	KI	01 8639 6375	-03	01 8639 6395	+13	01 02 40 19	01 02 47 21
0124+10	0147+14	35mm4perf	BCD	0023+05	Kodak	KI	01 8639 6703	-10	01 8639 6725	+10	01 02 47 21	01 03 02 19
0147+15	0185+03	35mm4perf	BCD	0037+05	Kodak	KI	01 8638 6088	-09	01 8638 6124	+11	01 03 02 19	01 03 26 16
0185+04	0223+08	35mm4perf	BCD	0038+05	Kodak	KI	01 8639 9961	-03	01 8639 9999	+01	01 03 26 16	01 03 51 04
0223+09	0236+00	35mm4perf	BCD	0012+08	Kodak	KI	01 7906 0802	-01	01 7906 0804	+06	01 03 51 04	01 03 59 04
0236+01	0253+02	35mm4perf	BCD	0017+02	Kodak	KI	01 8639 5470	-11	01 8639 5494	+06	01 03 59 04	01 04 10 03
0253+03	0296+02	35mm4perf	BCD	0043+00	Kodak	KI	01 8639 9752	-04	01 8639 9794	+11	01 04 10 03	01 04 37 16
0296+03	0308+05	35mm4perf	BCD	0012+03	Kodak	KI	01 8639 9862	-13	01 8639 9873	+05	01 04 37 16	01 04 45 11
0308+06	0333+10	35mm4perf	BCD	0025+05	Kodak	KI	01 8639 9608	-09	01 8639 9632	+11	01 04 45 11	01 05 01 16
0333+11	0384+06	35mm4perf	BCD	0050+12	Kodak	KI	01 8639 6154	-02	01 8639 6204	+09	01 05 01 16	01 05 34 03
0384+07	0415+06	35mm4perf	BCD	0031+00	Kodak	KI	01 8638 6205	-09	01 8638 6235	+06	01 05 34 03	01 05 53 24
0415+07	0438+13	35mm4perf	BCD	0023+07	Kodak	KI	01 8639 9938	-11	01 8639 9960	+11	01 05 53 24	01 06 08 24
0438+14	0450+06	35mm4perf	BCD	0011+09	Kodak	KI	01 8638 6797	-00	01 8638 6800	+08	01 06 08 24	01 06 16 09
0450+07	0489+11	35mm4perf	BCD	0039+05	Kodak	KI	01 8639 5206	-11	01 8639 5244	+09	01 06 16 09	01 06 41 13
0489+12	0505+13	35mm4perf	BCD	0016+02	Kodak	KI	01 8638 9007	-05	01 8638 9022	+12	01 06 41 13	01 06 51 21
0505+14	0529+10	35mm4perf	BCD	0023+13	Kodak	KI	01 8639 5882	-07	01 8639 5905	+05	01 06 51 21	01 07 07 02
0529+11	0539+14	35mm4perf	BCD	0010+04	Kodak	KI	01 8639 5918	-06	01 8639 5927	+13	01 07 07 02	01 07 13 16
0539+15	0587+12	35mm4perf	BCD	0047+14	Kodak	KI	01 8639 5720	-01	01 8639 5777	+12	01 07 13 16	01 07 44 07
0587+13	0677+07	35mm4perf	BCD	0089+11	Kodak	KI	19 3355 2465	-05	19 3355 2554	+05	01 07 44 07	01 08 41 17
0677+08	0838+11	35mm4perf	BCD	0181+04	Kodak	KI	34 3698 2208	-03	34 3698 2369	+00	01 08 41 17	01 10 24 22

The above photo shows a sample datasheet that we construct. I work with a software system that I found in Australia which takes the keycode information and then allows me to hand enter all the other pertinent information that the archives want, for example: Scene and Take, Camera Roll, Date shot, and Lab Roll. We can add fields which makes it possible to refer to the line script. We can add information about a shot which might have been used for visual effects. So all of this type of information is added to the data base. We can export it to File Maker, Excel, Oasis or put it into whatever software a Studio might use to manage their archives. The information is then searchable not just by key number, but by any of the data fields that have been set up - any way the customer wants it. We share all the information that we collect with the studio – it’s not proprietary – they own the data base.



After having seen that huge amount of negative which completely filled one vault with one million feet of film, take a look at the picture on the left. This stack of 100 boxes represents what was actually pulled to make the finished feature, cut slate to slate - a huge saving of space as opposed to the one million feet that you saw at the beginning. The “trims and outs” – all 950,000 feet of it or so - will be put in storage in Kansas or some other underground storage facilities. The picture on the right is the final exhibition print on seven shipping reels – approximately 14,000 feet of film.

Benefits: Doing this work is a good insurance policy because if you have to revisit the film, the editor who did the original work may have moved on to another project and is not available to do any changes that may be desired. Our work leaves a trail – a treasure map – to go back and redo anything that might be in the Digital Intermediate. A good example of this might be this: If a particular film was very successful but had originally only been scanned at 2K and the producers want to go back and rescan at 4K for greater impact, we can actually help them. We can get them to the ground floor because all of the original, selected takes are in order, ready to rescan and the data supporting the reassembly are immediately available.

Another thing that we have done is to actively protect the scan lists and all the original materials which were used for visual effects. Where this came to our attention was in a film that looked great on the theater screen and on standard definition DVDs but fell apart in the Blu-ray version. We realized then that as of that point, none of us had a way to recreate that visual effect. Since then, we have made a

point of creating a data trail and protecting all of the film sources which go into the visual effects of each film we handle. The key thing about the data trail is that it has to be exportable to your customer so that you're not holding them hostage.

The methodology that we use is actually old-fashioned library science: cataloging. There is nothing unusual about it. I did not invent anything, I just used the tools that were available to me.

Immediate needs: I think that we need to address how we are going to store and catalog images produced by digital cameras. This is a big discussion topic that I hear at every meeting I attend – How do we handle this data? Traditional negative cutters are not around much any more, but what we've done in the past can be applied to this in terms of data collection. For example, if you have a big, huge hit but want to make some changes, you've got to be able to go back and figure out what you did and how to get at those images. Right now that's tough.

Any questions?

Q: Do you make hard copies on paper of the data that's recorded?

A: Yes. Every box has a paper trail attached and every item refers back to an Assemble list and the Event Number and that includes an exact frame count of what was used.

Q: When you have an event or events which you need to duplicate, do you do this strictly from the lists or do you do an eye-match to the DI.

A: We're evolving how we do this. Some editorial groups have things really together and have everything they need, including the Quicktimes that they saved from work and the Quicktimes that they sent to the visual effects department. They are matched up with the data that we have which shows the actual frames they scanned. When it gets to many-layered visual effects, then that's when I'm really out of the picture. But I do have the paper trail and the Quicktimes that I store with the negative.

Q: So it's a visual reference?

A: Only the optical facility knows what happened to produce that effect, so we're trying to work with them to document exactly what they did to produce that effect. What I'm trying to do is have a copy of everything that goes with the negative, so that it's all in one place. We're still working on it though.

Q: Are separations still being generated along with the Digital Intermedia to protect the picture for the future?

A: Yes. They're doing them digitally. Several facilities are creating YCM separations from the final Digital Intermediate.

About the Author. *Mo's career in negative cutting acts as a parenthesis to the many opportunities she has had in her business life. Starting as a trainee at Universal Studios in 1974 - the first film she handled was Jaws - she became proficient at negative cutting while working at Quinn Martin Productions, Paramount Television, MGM and Columbia Pictures. In 1982, she left the film world to sell residential and commercial real estate in Beverly Hills and Orange County.*

In 1985, Mo turned a new page and became a production assistant for a TV commercial production company, working her way up to a producer of television spots and rock videos. The birth of her son, Logan put all of that on hold and when she was ready to rejoin the work force in 1992, she was hired as a negative cutter for Donah Bassett, who had the negative cutting accounts for Columbia-TriStar and Warner Brothers. In early 1993, Donah, who wanted to retire, offered Mo the business and it changed hands that year.

Since then, Mo has worked on hundreds of films, including the Spider-Man, Batman and Matrix series, all of Clint Eastwood and Woody Allen's films, as well as having the delightful job of living in London to cut the first two Harry Potter films. Under Mo's direction, D. Bassett and Associates was one of the first and few negative cutting companies to embrace the DI process, acquiring software from both the UK and Australia, which it continues to use as part of the DI line-up.

The process she pioneered: pulling select shots for the DI and logging and exporting the captured data to the scan facilities, has led her in another, unexpected direction - archiving film assets for Sony Pictures and Warner Bros. Mo has also had the challenge in the last few years of working on the restoration of several major motion pictures, including Apocalypse Now and How the West Was Won.

Along the way, Mo has produced a few short films and has optioned the book "The Search" by Geoff Dyer, which she is attempting to produce along with her UK business partner, Annie Nightingale of the BBC.

Mo is a native of Los Angeles and one of many of the Henry family negative cutters and lab workers who span four generations.



The Digital Nightmare: Practices to Future-Proof Your Digital Content

by Chris Lane

Right now, one of the many hot topics within our field is **data** and the lack of standards and procedures in handling data in a digital archive setting. Many moving image archivists hope to have a digital asset management system (or DAM, aka the archivist's Holy Grail) but realize that the feasibility of that happening right away is bleak. This has left many wondering what they should do right now with the continuous flow of data coming into their institution's collection. Of course some well funded archives are close to implementing a DAM or already have a fully functional one, however, many other institutions are far from having any kind of DAM and feel they will have to play a huge game of catch-up in the future. This article lays out a few basic ideas on what archivists who are unsure of what to do with their data can in fact do in the interim while they wait for that illusive "something better." (We are presupposing that they are presently shoving their data tapes and hard drives in a corner of a vault or anywhere else but under their desk.) There are many different philosophies on how to best protect digital assets for the future and I will attempt to outline some arguments in the topics below. This is by no means comprehensive but it is an effort to collocate a few of the different positions on the matter.

Currently there are a number of ideas floating around the archival web-sphere on what to do with digital assets. For example, those new to archiving digital culture ask if Gold DVD-R's really will last 100 years; while others wonder if there is a difference between storing on data tape or hard drive. Simply conceiving how digital asset management is described can put people into linguistic back-flips. And while it might seem that there is a new language to learn (one that is more tech-y or completely different from speaking about emulsion or sprockets), a few basic ideas in archiving organic film and analog video do apply to digital media.

As stated before, while standards do not exist for archiving data as they do for analog and organic elements it's not a bad idea to follow or at least consider the traditional precedent established for the long term storage of motion pictures. As an example, it is standard practice in the process of preservation and restoration of color motion picture films to create an interpositive (IP) and internegative (IN) as intermediates prior to the making of the final product

– a restored viewing print. In this process exact duplicates of content are created. Essentially, when all is said and done, the preservationist ends up with 3 preservation copies, the original, IP, and IN and the print is available for viewing, circulation, reference and of course serves as final confirmation of the success of the duplication/restoration project. The first three items serve as a proven form of protection of the films content. The same follows suit for video archives that make protection masters of their original masters. The rationale behind this is if you loose one or if one is damaged, you still have the other, untouched; this concept is crucial and totally applicable in archiving data. Maintaining only one copy of original data files is about as risky as only having an original negative. If something happens to that original copy, you are up against a greater possibility of completely losing the content. Two copies of data lower the risk of losing all content; however, if you loose one copy, you're still left with one copy. Three copies ensures protection as you end up with a back-up of your back-up and the probability that two copies become corrupt or un-readable is not as likely as one copy, but at least you remain prepared if that does occur.

Not every piece of data is worth having three copies. Indeed the cost of storing, maintaining, and migrating three copies of each digital asset can turn out to be quite a pricey endeavor. As the keeper of this material, the archivist will need to stratify and determine which assets should have three copies and which assets really only require two. Digital content will only increase in the moving image archive and it will be advantageous to have a policy in place from the beginning regarding a uniform handling procedure when dealing with newly acquired assets. Of course each institution is different and subsequently each will need to decide how to structure this idea in its preservation and acquisition policies.

Checking the AMIA listserv, there is always a heated debate over what the best format is to store digital data and it usually comes down between linear digital tape and hard disk drives. Many experts on the matter do not trust hard disk drive storage simply because if the drive fails, you loose all the data on the drive. The spinning disks in the drives lose their lubrication and consequently are unable to read data because the disk can no longer spin. There's a deep-rooted fear that the archivist will one day flip the switch on the hard drive to migrate or access data, and is left to discover that the drive won't spin and all data on the drive has been lost. This has led many to believe that the hard disk drive is only a transitory medium and that data should be stored on sturdy digital tape such as the Linear Tape-Open (LTO) varieties.

Linear digital tape relies on a simple tape path to write the data – there are fewer moving parts to write and read the data in a linear fashion, so there is a lower possibility of something going awry in the process of reading and writing. LTO is also a format that is supported by many different manufactures, thus different decks made by different companies can theoretically read the tapes. As well, LTO stock is small and compact, holding gigabytes (LTO-3 & LTO-4 stocks) and terabytes (the upcoming LTO-5 stock) worth of data. Because of this (and other more detailed reasons), it is thought that LTO stock for archiving data is the best solution we have at this point in time.

Studios and some archives have followed suit and currently store ProTools sessions, .DPX files (DI picture files), and many other audio-visual data files on LTO. While the simplicity, compactness, and low-cost nature of LTO is quite attractive to those currently in the middle of the digital torrent and while LTO stock can prove to be advantageous for particular aspects of library management, linear digital tape can also pose problems from an archival point of view. One reason is that the newer generations of LTO decks are only backward compatible with LTO stock by two generations (in other words, LTO2 stock can be read on a LTO4 or LTO3 deck but cannot be read on the upcoming LTO5 deck). Another reason is due to the difficulty in accessing data on the stock for migration or data replacement purposes. As stated before, LTO stock is linear storage on tape – it is not a random access storage device. Of course it is very simple to write to LTO and it can be very simple to read data from LTO stock, however, it can be a very long and laborious task because the simplicity slows the read/write time down since all data is in a predetermined, linear path. Data cannot be randomly replaced or accessed as it can be on a hard disk drive. If changes or replacements must be made to the files on LTO stock, the entire data set on the tape must be rewritten – even if to just replace one file. Thus, if one file is changed and must be replaced on the LTO archive, one must unload an entire data set on that LTO, replace the one file, and re-write that LTO again. Data on a hard disk drive does not yield such problems since data can be randomly replaced or added. As well, migration of data from one hard drive to another hard drive is a relatively simple task due to the fact that the hard drive does not require data to be written in a particular fashion as the LTO does. Data can essentially be dumped from one drive to another without requiring a predetermined structure to write the data on the new reciprocal.

When looking at the advantages and disadvantages of LTO and hard disk drives, we are left with the question as to which is the best medium to function as the next step an archivist should take when future-proofing a digital collection in preparation of the digital asset management system they hope to have in the future. It all comes down to the archivist's comfort level and what seems to be the best route for the collection. Repositories with the resources to have dedicated staff towards digital content management might seek to store assets on hard disk drives as spinning disk storage requires the institution to have an active role in their management by turning on the drive in a scheduled period of time. Those institutions without such resources might need to go the passive route and store to LTO, but at the same time must be aware that they will need to have massive migrations periods to stay current with evolving LTO decks and stocks. Other archives might not have the budget or might not hold a large amount of digital content to write to LTOs or hard drives and will instead look towards optical discs such as Gold DVD-Rs that are cheaper to purchase and can hold a much smaller amount of data than hard drives or LTO stock. On the other hand, some institutions might decide to go with both LTO **and** hard disk drives in an effort to spread the risk of data loss between two different storage media.

Storing copies of data on both LTO and hard disk drives might seem an ultra-conservative and hyper-skeptical approach to digital asset management, but it does

dramatically reduce the risk of losing assets while it also allows duplicate copies of the data to be made at the same time. The combination of multiple storage media and multiple exact copies of digital assets allows the archive to combat the statistics of content loss and leaves the archive's content even more protected from the "what if" factor. The archive can subsequently treat its digital assets as it does its film and video assets where it is common practice to separate 35mm positives and negatives and store them in different vaults or even in completely different locations. LTOs and hard drives that house the exact same content should be separated from each other in different vaults, storage sites, or on opposite sides of the world. For example, a content holder can have two copies of a data set on LTO-4 stock and 1 copy of a data set on a hard disk drive. Each physical asset holding a copy of the digital data can be stored in 3 different locations just as 35mm negatives and positives are separated.

Perhaps the most daunting concept in all of this is the cost of managing data at the current moment. Purchasing LTO stock and LTO decks or placing bulk orders for hard disk drives is certainly an expense most moving image archives are not accustomed to in today's economic climate. However, money must be sliced out of the budget for this now if an archive is sitting on a pool of stagnant digital assets. It is better to save the content while it is still intact, rather than 20 years from now when the content may not be salvageable due to any number of factors including obsolescence (in physical medium and file format), corruption, and the aging of tape. Digital assets are produced quicker than archives can manage them and archives must have an active role in ensuring that these valuable assets are preserved for future use.

Moving image archivists already can see how their job description is changing due to the onslaught of digital media. With these changes, it is of paramount importance that we hold onto our common practices and standards that have worked for us in the past while at the same time we look towards the future. How we nurture our future relationship with the information technology and computer professions is essential to insuring that digital content is given continued life in the archive. This is truly **the** major concern facing all of us in the near term. Stay tuned!

About the Author. *Chris Lane is the Acquisitions Manager with MGM Technical Services where he works with film, video, audio, and data. Chris combines post-production, restoration, digital intermediate, and archiving to help manage the MGM library with the rest of his team. Before joining MGM, he worked at Laser Pacific in their digital intermediate division where he managed and organized in-house work for visual effects, digital compositing, and DRS performed for feature film digital intermediate production. He received his M.A. from UCLA's Moving Image Archive Studies Program and received his B.A. from the University of Southern California's Critical Studies program in Cinema-Television and is the recipient of the Kodak Fellowship in Film Preservation.*



Type A and The Everly Brothers Show

By Ralph Sargent with Al Sturm

In the late 60's I was teaching a motion picture production course at UCLA using an RCA TK-10 Image Orthicon camera in lieu of film. The TK-10 fed into a Sony TCV2010 videotape recorder. As each day's shooting was finished, the best takes were transferred to film via a kinescope recorder and eventually, after the semester's work was done, the edited feature was shown to the class and other interested parties and then tucked away.

In an effort to improve picture quality for subsequent semesters, I bought an Ampex 7500 1" Type A machine to replace the CV Sony. The RCA camera put out beautiful pictures and the Ampex finally provided a means of recording them which was head and shoulders above the Sony.

Now, flash forward more than 35 years to 2001. I still owned the Sony and the Ampex and as part of our regular company work we did and still do transfers of obsolete formats using these and other machines. While Sony CV tapes surfaced frequently to be transferred from *that* decidedly obsolete format, Ampex Type A tapes almost never came in the door. However one day an inquiry came from Sony Pictures Entertainment asking if we could transfer two 1-hour color shows from Type A tape! The shows were episodes 1 and 2 of "Johnny Cash Presents The Everly Brothers Show," a 1970 summer replacement show on ABC. Could we do it? The answer was that we would give it a try.

The transfer of the "Everly Brothers Shows" to Digital Betacam from Ampex Type A tapes turned out to be a challenge to say the least. Though originally produced on 2 inch quad tape, the broadcast masters no longer existed or at the very least have never resurfaced since the show hit the air. The off-the-air Type A tapes and a few scruffy off-the-air copies on VHS are all that we know of today.

As a method of videotape recording, Type A was never the most robust tape format ever developed. Part of this lies in the design of the machines and the balance of the problems came from the state of development of the tape used with Type A in its heyday.

The fundamental concept for Type A was helical recording - a format of videotape recording which was thought of at the same time that the Quad format for 2" tape was conceived. It was abandoned early on for broadcast applications because in the 1950's there was no means available to correct for the timing errors inherent in its concept. On the other hand, properly made Quad recordings for black and white were inherently more stable and could be used on the air without further timing correction. For this reason Quad became the de facto standard for broadcast use.

After the initial success of 2", Ampex sought other markets for videotape recording. Zeroing in on the educational and industrial market, they realized that neither of these needed the timing stability that broadcast required. One other thing was obvious too - neither of these markets could afford to use high-priced quad machines and tape. After scratching their corporate heads the answer became obvious: helical. Subsequent to a brief flirtation with 2" helical designs, a 1" version was developed which seemed to fit the bill and this was what became Type "A" (for Ampex.) Type A machines cost a lot less to make and the tape they used was ½ the width of broadcast tape and correspondingly cost less to buy. It was almost like the difference between 16mm and 8mm film in terms of economy for the average user. What an idea!

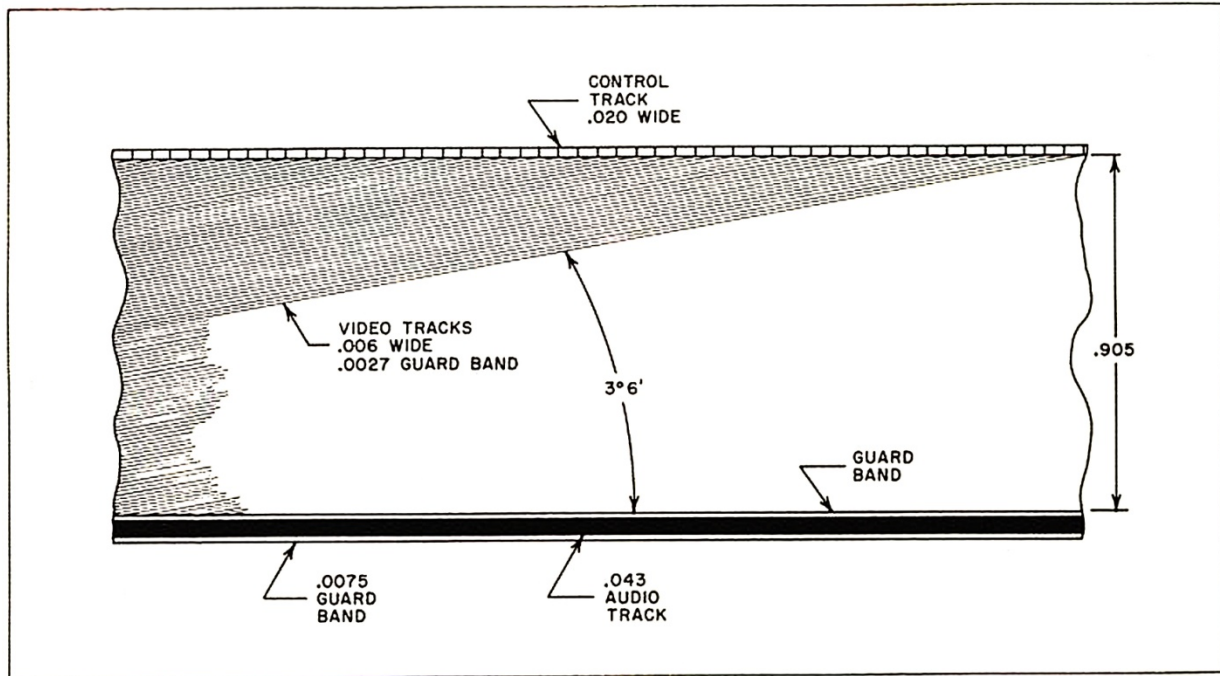

Figure 1. A schematic layout of track positions on Type A tape.

In regards to the Everly Brothers Show on Type A, the following problems had to be overcome: some were inherent to the design of the format and some were because of limited technological sophistication at the time these machines were current.

- 1) A fundamental fact about "A" format machines is this: They use a helical wrap that is **not** a full 360 degree wrap around the head drum; therefore each revolution of the head drum recorded **almost** 1 field of picture. The reason for this is that the tape actually leaves the drum in such a manner that approximately 9 horizontal lines of signal loss or dropout occur for every field of picture. (See figure 2.) This loss was nominally placed at the bottom of the picture and timed to end two horizontal lines before the vertical blanking interval preceding the next field of picture. By doing this, the vertical sync pulse was left intact and made vertical lockup of picture monitors possible. But this part of the design sure did mess up the very bottom of the picture!

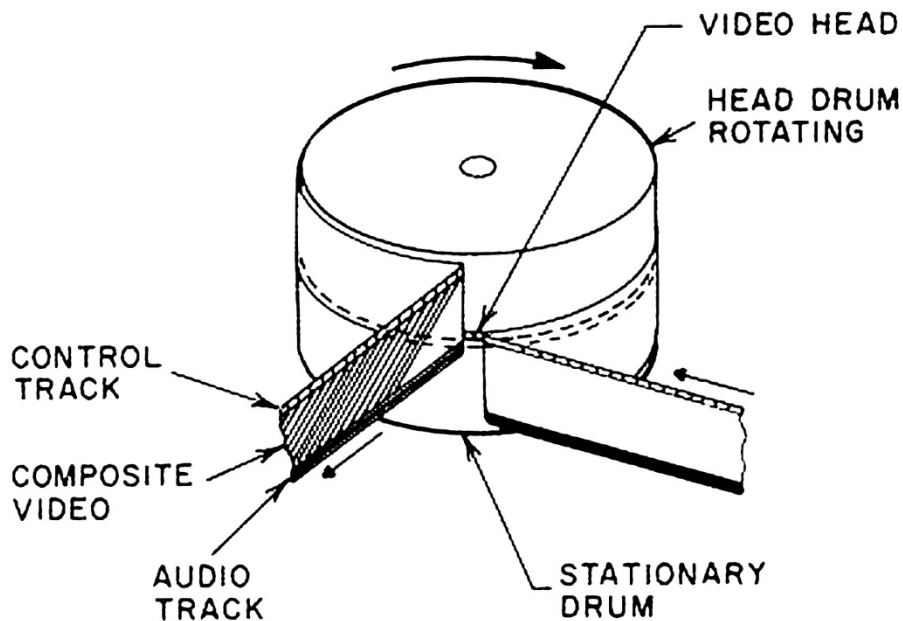

Figure 2. Tape path of a Type A machine

- 2) An example of limited technological sophistication was this: The tape on which the shows were recorded was of “Ampex” manufacture. The fact is that in the mid 60’s or so Ampex had just bought Orr Industries, a tape manufacturing company located in Alabama and notorious for making and selling terrible tape under the name of “Irish.” Anyone who used Irish tape on professional audio machines in the 50’s goes into paroxysms thinking of the troubles that Irish tape produced during recording sessions. The early videotape made under the Ampex label at the Orr facility, whether 2 inch for quad recording or 1 inch for type A, also had tremendous problems with wildly varying RF levels, head clogs, stiction and dropouts! The situation had only slightly improved by the early 1970s. Truly, this was the tape from hell! It is quite likely that if the recording had been made on fresh 3M tape at the time, chances are that there would not have been nearly as many physical problems encountered during our transfer sessions, almost forty years after the original airdate. 3M had far more experience **making** good videotape at that time than Ampex (ne Orr Industries).

- 3) The reels of tape used for recording “The Everly Brothers Show” had been used repeatedly before these shows were recorded on them and were by no means in pristine physical condition.
- 4) The recordings themselves were not made by a hard-wire feed at ABC. Instead they were made off-the-air somewhere in Los Angeles using a modified television set or A/V tuner. Unlike today, in the early 70’s **standalone television tuners** were very uncommon in non-broadcast facilities.
- 5) A further complication was that the setup for doing off-the-air recording seemed to either change or be modified on a week-by-week basis. There was no consistency from one show to the next in this regard. Uncontrolled video gain produced pictures which were distorted causing over-modulated highlights and exaggerated system noise. An additional complication of over-modulation was that the pre-emphasis and de-emphasis built into the recorder’s video path would no longer be complimentary causing serious disturbances to black level and sync reproduction. And finally, sound levels also were extremely hot. In other words: whoever made these recordings had no equipment to monitor the signal levels of either the sound or the picture. He or she was flying blind and deaf and it’s amazing anything useable got on the tape at all!
- 6) Another potential pitfall of off-the-air recording is ghosting. (Engineers call it ringing, but homefolk call it ghosts.) It’s a series of fainter and fainter repeats of an image to one side or the other of the primary image. Usually it’s caused by the off-air signal bouncing off of the sides of buildings in the line of sight between the transmitter and the receiver of the television signal. “The Everly Brothers Show” had this in spades!
- 7) Type A machines of the time had never been intended as source machines for transfer to much newer formats which required solid, time-base corrected signals.
- 8) A frequently encountered problem with Type A machines in general concerns the inter-changeability of recordings made on one machine and their playback on another. Luckily this type of failure was not encountered with the Everly tapes and the machine(s) we used.

- 9) The particular model Type A machine used for this project was not built to reproduce color using a timebase corrector even though it could do so using a specially modified color monitor.

To successfully wend our way around these problems we used an Ampex TBC-6 timebase corrector which was normally used with much later Type C recorders. The TBC-6 required that the Type A machine be capstan-locked to advanced sync from the timebase corrector and also that a buffered off-tape RF signal be sent to the TBC's dropout compensation circuitry. All this sounds relatively simple until you contemplate just how you're going to lock a hysteresis synchronous motor to color sync. The answer was to use brute force.



Figure 3. An Ampex VR7500, the machine used for the 2001 transfers.

Using parts from an Opamp Labs 100 watt audio power amplifier and additional conversion circuitry, the motor was fed 90 volts AC sinewave derived from the TBC's advanced sync output. And finally, the off-tape RF was buffered and shipped back to the TBC to run the dropout compensator. Fine and dandy, but....

The "BUT" is this: the synchronizing signal on the tape was seriously distorted because of the antenna location, the Rube Goldberg tuner setup and no accurate manual or automatic means of monitoring and adjusting signal levels. This distortion caused the TBC to hunt for what it "thought" was the start of each line or video field or

frame. Unless the playback was carefully monitored and adjusted as it went along for level and color saturation, the TBC would tend to shift the horizontal and/or vertical position of the picture. Manual control of these signals presented the playback operator a “high-wire act” or, seen from another perspective, this was like skating on ice with bum skates or ice made out of Jello. In spite of this the job got done and everyone seemed pretty happy with the results.

Let’s jump forward seven or eight years. Someone discovers five more “Everly Brothers” shows and once again we are asked to resurrect Type A from the bowels of our storage facility! Well in the duration between the first go-around and 2008-9, we were offered two Ampex model VR7800 Type A machines from an east coast university. We understood that if we didn’t accept them they would meet the underside of the university’s bulldozer at the local dump and we’d be no better off than we were in 2001.



Figure 4. A VR7800, the machine used for the 2008-2009 transfers.

On the other hand we had to recognize that even though these VR7800 recorders were advanced 1 inch machines for their day, by comparison to 2” machines produced at the same time or Type C 1 inch machines that came a few years later, these machines were a bar bones product. They had no video processing amplifiers or time base correctors - both of which would be necessary to overcome the inherent deficiencies of any helical videotape format and make a video signal that was acceptable for transfer to modern recording formats.

On the plus side, the VR7800 was probably a better machine to use than any of its predecessors. At least this model would lock to external sync without modification and there were test points on the demodulator cards from which off-tape RF could be measured and used to produce initiating pulses for the external TBC’s dropout compensator. (Advanced sync from the TBC delivered to the VR7800’s external sync

input allows the user to center the timing of the reproduced video in the middle of the correction range of the TBC.)

During the acceptance process we had to face a few other things:

- 1) The machines were offered “as is” and neither one worked when received.
- 2) There were no manufacturer’s manuals available either from an operational or maintenance standpoint. No schematics; no nothing!
- 3) The capstan shaft covering had completely disintegrated leaving no hint as to what the working diameter originally was.
- 4) Practically all of the operational electronic parts throughout the machines needed to be checked and/or replaced.
- 5) The machines had not been run in years and there was no guarantee that they could be made to work.

Well, if the machines were so bad, why pursue fixing them? Here’s why:

- 1) Capstan, head drum, feed and takeup motors were all servo controlled, providing they all could be made to work!
- 2) The tape handling of the machine was many times better than the previous model we used.
- 3) The capstan itself was a “split” type which took much stress off the tape as it passed the rotating video head drum.
- 4) And, as had been said before, electronically these machines came very close to being “air-worthy” and just needed the extra “push” to get them there.

In short, the engineering of this model was light years ahead of our previous model. The over-riding need then was to take the two non-functional machines and combine them into one which would form the foundation for a serviceable broadcast videotape recorder.

The first step was to dummy up the capstan shaft to approximately the right diameter and run a test tape on the machine to see if it would play. This would also let

us select which of each pair of electronics cards showed signs of life or were close to working. (Just so you know, more than thirty different cards had to be tested.)

Surprisingly, the first go-around was successful in producing a jumpy but recognizable picture. In spite of the fact that the capstan shaft had a very imperfect diameter, it was obvious that if we stuck to doing a full rehabilitation we stood a reasonable chance of bringing model VR7800 back to productive life.

The next step was to get some outside help.

First of all I asked Al Sturm to join the party. Al had a pivotal role in an earlier project for us and I knew he would be exactly the right man to determine and design whatever new and modified equipment we'd need to do the Type A project right. The key to it was going to be Al's design for an interface box which would go between the Type A machine and whatever modern TBC we chose to process its signals. The interface box would either reshape the distorted sync pulses on the Everly Brothers tapes or replace them with new ones which were much cleaner than those coming off the tape. We wanted to get a picture which had a minimum of positional shifts no matter how bad the tape sync!

Al suggested that I get Ken Zin in Palo Alto to do the general electronic and mechanical resuscitation of the machine. This project was right up Ken's alley and he jumped at it. The machine that we had selected previously, along with the selected electronics cards and a complement of test tapes, was driven up to Ken's place and he began work.

One of the earliest things we asked Ken to do was to pull the capstan shaft parts and send them over to George Athon in San Francisco. We had met George at the National Association of Broadcasters Convention in Las Vegas the previous year and remembered that he owned a company which could recoat parts such as this with special surfaces which matched the characteristics of the original materials on the shaft. On top of that, George had the exact specifications for these shaft diameters as he had done similar work for Ampex Corporation when these machines were new.

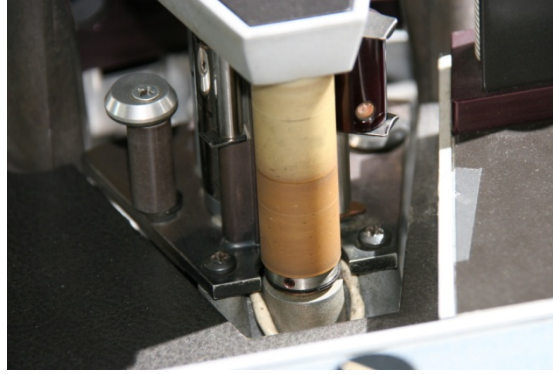

Figure 5. The rebuilt split (two-section) capstan shaft, after some use.

(I should point out that Al, Ken, and George had each worked at Ampex in Redwood City during the heyday of Quad and later Type C recorders and knew their specialties from the inside out.) When we received the machine back from Ken, we started to work on the signal electronics. Take a look at Figures 6, 7 and 8:

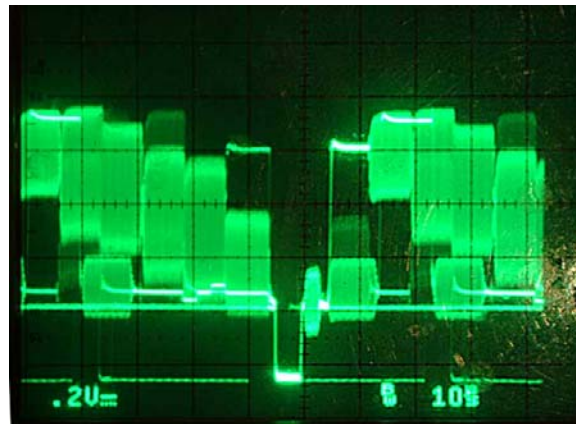

Figure 6. E to E video and sync waveform through the VR7800's electronic system.

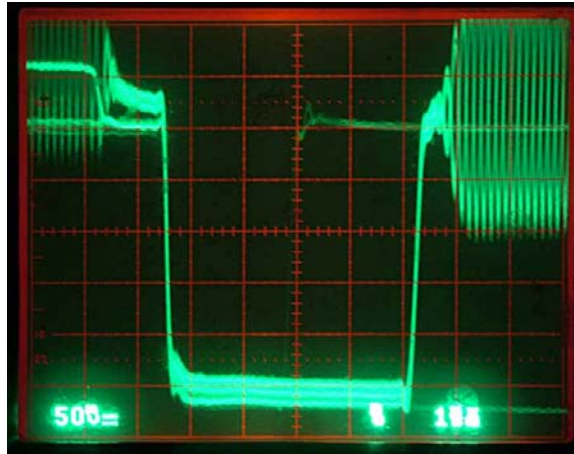

Figure 7. A closeup of what would be considered to be “good” sync.

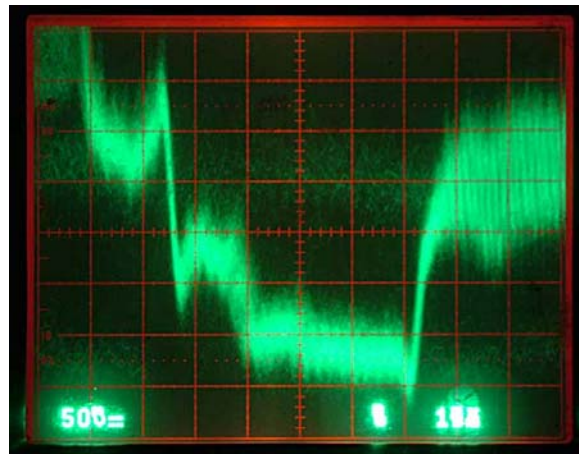

Figure 8. Closeup of actual off-tape sync we had to work with – not very good...
In fact, it was truly awful.

Obviously the first step in solving this problem was to do a “shoot-out” between various manufacturers’ time base correctors for their operational characteristics and ability to function properly when fed badly formed and unstable sync and video signals. The first machine to be tested was an Ampex TBC-6. It faired quite well.

The second TBC was a Sony BVT-800 which turned out to be a good device, but not for this application. It really was intended for “color-under” or heterodyne-color machines such as VHS or Sony Umatic ¾” players, not for “direct-color recording” applications such as this.

The third machine was a NEC NTC-5000. This is quite a remarkable TBC. It was designed to handle almost anything: quad, direct-color and heterodyne recorders, but in this application it didn't quite match the stability of the fourth machine we tested, the Ampex TBC-80. Ultimately it was the Ampex TBC-80 which won because of its ability to plow through rotten sync and still turn out a solid image.



Figure 9. An Ampex TBC-80 Time base corrector with cover removed.

The final question of how the VR7800 and the TBC-80 were to be coupled was answered by AI's design for and construction of a hand-built interface unit.

Here's what it did:

1. Take in buffered off-tape RF and playback tachometer pulses and generate the video and dropout pulses which were sent to the TBC causing it to repeat the last line or portion of video where noise pulses (dropouts) occurred in the video. As a result of this processing, the final picture contains but a fraction of the junk that was really coming off tape.
2. Perform sophisticated sync separation from combined video and sync (composite video) in order to generate a window to increase gain during sync time. The off tape sync was then clipped to make a clean sync pulse to be sent to the TBC for accurate timing.
3. Perform low pass filtering to reduce the overall noise in both picture and sync.
4. Provide a cosine equalizer centered at 3.58MHZ. This enabled us to adjust the chroma level since the equalizer on the VPR7800 created more problems than it helped.

5. Pass all new or modified signals on to the Ampex TBC 80.

6) As a final step, a few modifications were made to the Ampex TBC 80 to let it accept the cleaned-up signals from the video processor.

Though the result of all this effort isn't perfect, most all of the recovered video is far and away better than ordinary 1:1 transfers might have produced. Careful editing is the next step if these materials are ever to be used for compilation purposes. The wide range of musical artists presented in these shows makes them unique documents of their time and fascinating entertainment to boot!

About the Authors.

Ralph N. Sargent III received his B. A. in radio, television and motion pictures from the University of North Carolina, Chapel Hill in 1964. He earned his M. A. in motion pictures from the University of California, Los Angeles and joined the technical staff of UCLA's Motion Picture Division of the Theater Arts Department following graduation in 1965. In 1968 he was appointed a lecturer at UCLA teaching both technical and production courses.

Sargent formed Film Technology Co., Inc. in 1971. The company has grown to become one of the premiere restoration laboratory facilities in the United States serving both film, video and sound clients throughout the world.

Sargent is the author of "Preserving the Moving Image" published by the National Endowment for the Arts and the Corporation for Public Broadcasting, 1974. He was a contributing editor and advisor for the National Film Preservation's publication, "The Film Preservation Guide: The Basics for Archives, Libraries and Museums," 2004. He is a life member of the Society of Motion Picture and Television Engineers and a member of the Association of Moving Image Archivists. He has contributed lectures and presentations to both organizations touching on a wide variety of technical devices and techniques of interest to the field.

In less directly related fields, Sargent is a past chairman and honorary life member of the Los Angeles Theatre Organ Society and a producer of numerous silent film scores and theatre organ recordings. He is also a member of the Society for Astronomical Sciences and an astrophotographer whose deep space photographs have appeared in Astronomy Magazine.

Al Sturm claims the following is malicious gossip - Al Sturm is president of Wide Band Video Labs, San Jose, Ca. (Wide Band Video Labs is a custom video design laboratory responsible for development of digital and analog prototype and pre-production systems.) Previously Al was Director of Engineering at Merlin Engineering in Palo Alto, where he managed the development of high band signal systems for the modification of Ampex and Bosch broadcast video recorders. He has also consulted on the engineering design of high band videotape recorders for smaller TV operations. At Ampex Corporation, he was Field engineer for the installation, training and maintenance of broadcast video recorders.

Projects and clients have included: SYKCORP - Demodulator, Scan Converter, Video processor for an Ampex FR900 to recover video from the Apollo 11 Lunar Orbiter tapes; FILM TECHNOLOGY CO., INC. - Enhancement systems related to the printing of archival 35 mm films. INTEL Inc. - Design and test of a computer controlled automatic video parameter tester for the X-BOX game console. LOCKEED CORP. - Analog input RAM based digital recorder for use in analysis of satellite video. IVC, Inc. - High Definition 24 frame film-to-1080i 30 frame rate converter. INTERACTIVE SYSTEMS, Beaverton, Or. 525 OR 625 serial digital in and out broadcast video data encoder. IVT MEDICAL, Newtown, CT. An svhs multi-standard digital time base corrector (1023, 1049, 525, 1249, 625 line STDs). LASER-DUB, Inc, Santa Ana, Ca.--A twice speed modified laser-disc master head end, with digital processing for a high speed VHS dubbing system. (Patent issued) USP # 5,260,800 MERLIN ENGINEERING - Wide band (10 MHz) 1" BCN vtr modifications. High band fm signal system for modification of older broadcast video tape recorders. SATCORP, Inc. New York.--A 12 Mhz analog bandwidth component 1" BCN fm signal system and digital time base corrector. WALT DISNEY IMAGINEERING - Very wideband RGB graphics coaxial distribution amplifier



The Problem of the Inside Out Tee Shirts

by John Menke

Introduction

In the lives of mankind, there are many, many questions that arise about man's place in the universe, and what kinds of dark forces lurk therein. There are issues of disease and plague, war and violence, floods and hurricanes which face us all as well as the truly dreaded and irksome mystery of Inside Out Tee shirts. An undercurrent of concern flows through our societies as we try to understand that phenomenon: do washing machines engage forbidden forces that turn tee shirts inside out (i.e., tee shirt flipping), or is this human negligence as we forget to keep them outside out when we load the washer. The Answer and its Cause follow.

Observations

After finally taking note of the considerable incidence of Tee Shirt Flipping (TSF) occurring during many years of *"doing the wash"*, I began taking careful data in January 2009. The top loading washing machine was a venerable Hotpoint, ca. 1986. When first purchased, it was noted that it did tend to wind up clothing, sometimes literally tying shirtsleeves in knots and similar feats. That behavior never stopped.

The project period covered all of 2009. Washer loads contained only medium sized male tee shirts (with short sleeves), and occasionally, the addition of a few handkerchiefs. I was careful to verify that all tee shirts went into the machine right side out, i.e., outside side out. Tee shirts were both old (thin) and new (thick.) In general, I used a reduced water level and a six-minute cycle for the tee shirt loads. The loads were done approximately once per week, and loads generally had 5-10 tee shirts. Some loads produced tee shirts that were only partially turned inside out, these were counted as 0.5. When the washer load completed processing, the shirts were removed one by one and hung on a line (i.e., not machined dried or tumbled). In December 2009, the Hotpoint washer failed, and the replacement Maytag went into service (see below).

Results

The first graph shows each load in sequence during the project, and each data bar gives the fraction of inside out shirts along with the cumulative average of the fraction of tee shirts turned inside out. The reader can see that approximately 1/3 of the shirts engage in flipping behavior. The number of tee shirts each load was 7 \pm 2.

The second graph shows a plot of fraction of shirts flipped in a load, vs. the number of shirts in that load, i.e., the Flipping Factor. Clearly, there is an apparent decreasing trend--the more tee shirts in a load, the smaller the fraction flipped. Perhaps the Tee Shirts exert some kind of gravitational tug that inhibits Flipping.

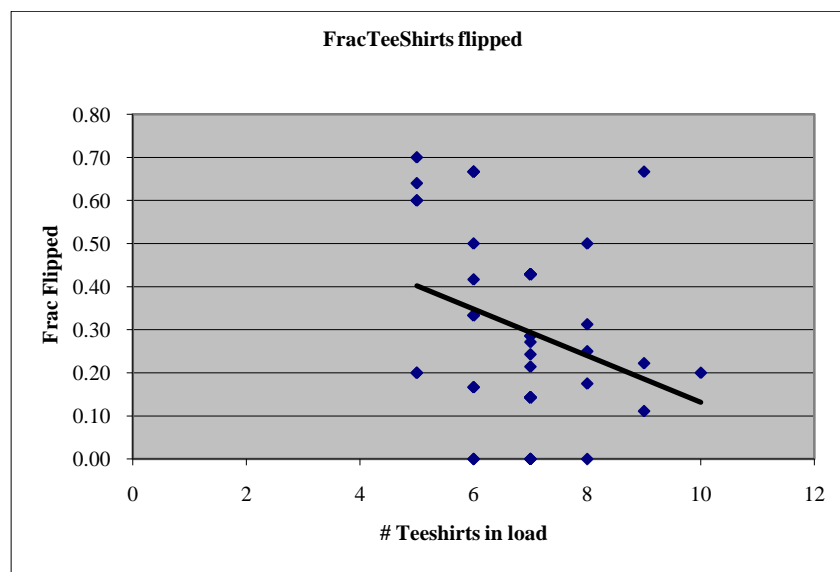
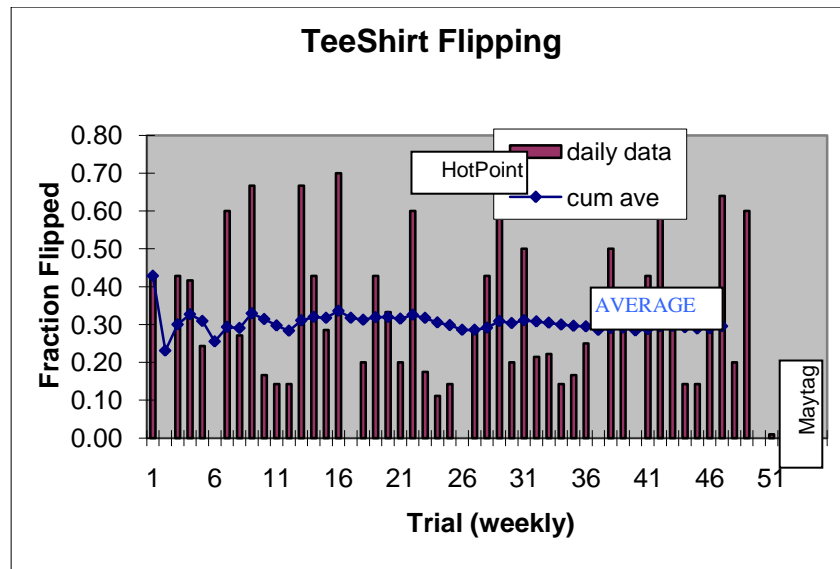

During this research, I saw no correlation between age or cleanliness of tee shirts and the Flipping Factor, the depth of water, nor whether there was a handkerchief present in the load.

Some statistical interpretation of the results is required for proper understanding of the results.

For example, an obvious question is whether all the tee shirts are being flipped many times, and at the end of the process, we happen to see the results. A related question is what one would see (i.e., how many tee shirts are flipped) if the wash cycles were stopped at various times to inspect the results (or if a transparent window were introduced into the washer or if a video camera were used to monitor the washer load).

In, any case, the data show that the tee shirt flipping is simply random at low rates and generally follows Poisson statistics. The data never showed all tee shirts flipped, but frequently showed only a very small fraction flipped. Thus, we know they are not all being flipped back and forth many times, or we would have observed a 50% average (rather than the 30% seen) and we would see as many loads in which nearly all tee shirts flipped as very few flipped. It is, of course, conceivable that there are weird effects occurring (e.g., those that flip do so in the first minute, then no others flip). However, there is no reason and no data to suppose they do, and such action would almost surely show as a different statistical result.

Using simple statistics, because the data show that 1/3 of the Tee Shirts flip, it is almost certain that roughly 1/3 of these have flipped a second time, ending up right side out. That is, of 10 Tee Shirts, approximately 3 will flip once, 1 will flip twice, and the remaining 6 do not flip.

Another question is what would happen with only one Tee Shirt in a load. The graph indicates that perhaps 2/3 of single tee shirt loads would show a flip. However, this was not investigated. Excessive water consumption and cruelty to washing machines would argue against such a line of investigation.

Another question relates to the observed number of partial flips. As noted, we did see occasional cases of a tee shirt partially flipped amounting to about 5% or so of flipped shirts. This small fraction would imply that once a flip starts, it proceeds fairly quickly to completion.

Finally, although not a statistical question, it is clear that we do not know how the tee shirts flip, i.e., through the waist, neck hole, or via an armhole nor the direction of the flip. Nor do we have data on whether sleeveless tee shirts would behave differently. However, many similar loads with long sleeved business shirts almost never showed a flip. Although these were washed with front buttons undone, the sleeves were not turned inside out (though they were frequently tied almost in knots). Video monitoring of loads (or use of *loadus interruptus techniques*) would likely answer this question.

In December 2009, an event occurred that totally changed the universe of TSF research: the Hotpoint washing machine broke. After only 25 years of use, the agitator internal spline sheared off. After repairs proved unsuccessful (and a replacement agitator rejected as being over-priced at an outrageous \$95-100), the defunct washing machine was replaced with a like-new second-hand top loading Maytag washer (found on Craigslist for \$50). Continuing to take data, it became clear very quickly that the unique flipping properties of the Hotpoint were no longer present. The new washer does not tie clothing in knots, does not twist sleeves into pretzels, and does not flip tee shirts. The new Maytag is, in fact, very boring. The result is that we cannot pursue additional research in the foreseeable future. Thank goodness.

Agitator Agitation

From the many people who have heard of this research, one who wished to remain anonymous asked about the differences between the Hotpoint and the Maytag. They are both top loading, so-called "heavy duty extra large" washers. tubs are almost the same size with Hotpoint being 21x14 deep and the Maytag being 21x15 deep. The agitators different. The Hotpoint is 12-in. dia. and Maytag is 11-in. dia. However, the Hotpoint has three curved blades about three inches high tapering to zero at the full diameter, while the Maytag has four straight radial blades 2-3 inches high (it also has a small second set high on the agitator, but these do not engage during the shallow Tee shirt loads). It also appears that the Maytag agitator oscillates at a higher rate through a smaller arc as compared to the Hotpoint.



The
are
the

While the agitators do not appear radically different, the sloped and curved blades of the Hotpoint as they oscillate back and forth will tend to create a net, repetitive rolling action in the water leading to a net twist in any garment floating in the water. That is, the rolling action of the water will not average out as the agitator rotates back and forth, as compared to the Maytag which is symmetric in its back and forth turbulence. Thus, it is entirely plausible that the Hotpoint will tend to align the clothing around the agitator, and will then tend to wind it into tubes/ropes which will then tangle together - exactly as seen with shirt sleeves and the like. How this leads to aggressive Tee Shirt flipping is not obvious but is presumably related to the observation that the Hotpoint turbulence does not average out to zero whereas the Maytag does.

Other explanations of Tee Shirt flipping have been proposed (see <http://searchwarp.com/Q:4780-Why-Are-Clothes-Always-Inside-Out-When-You-Pull-Them-Out-Of-The-Washing-Machine>)

However, no data were supplied to support the various theories discussed.

Conclusion

So the End Of An Era is at hand. The Hotpoint is Dead; Long Live the Maytag. But the Hotpoint survived long enough to help answer the TSF question that has occupied science since Charles Darwin washed his dirty laundry after the gulls following the Beagle messed up his own tee shirts. The proof is in the pudding: Some washers DO flip tee shirts!

About the Author. *John Menke is a Physicist who got his BS from Rensselaer Polytechnic Institute in 1962. He worked at the Bureau of Standards (now NIST) for 12 years on the electron linear accelerator, then switched to politics when he ran for and was elected to the Montgomery County Council in Maryland. After his Council service, he was defeated in a bid for another public office. He then joined Mitre Corporation where he worked on energy and environment issues. In 1982, he returned to county government as an appointed department head, working for the person who had beaten him four years earlier. In 1988, he left that position and returned to Mitre Corp. in a variety of assignments. In 1991, he and his wife started and ran Technical Innovations, a manufacturer of fiberglass astronomy observatories. They sold the business and retired in 2002.*

During this time, John has continued what he calls basement physics. This has included construction and operation of a succession of seismographs, a variety of other instruments, and the recent Tee Shirt study. He operates two astronomical observatories at his home, and conducts a variety of related research efforts.