

EXHIBIT K

(19) **United States**

(12) **Patent Application Publication** (10) **Pub. No.: US 2004/0041504 A1**

Ozolins et al. (43) **Pub. Date: Mar. 4, 2004**

(54) **BEZEL-LESS ELECTRONIC DISPLAY** (52) **U.S. Cl. 313/110**

(76) Inventors: **Helmars E. Ozolins**, Orient, NY (US);
Masamichi Udagawa, New York, NY (US)

(57) **ABSTRACT**

Correspondence Address:
BROWN, RAYSMAN, MILLSTEIN, FELDER & STEINER LLP
900 THIRD AVENUE
NEW YORK, NY 10022 (US)

A bezel-less display is disclosed that includes an electronic display device and a cover. The electronic display device has an image-displaying portion and another portion adjacent the image-displaying portion along at least one side. The cover is positioned adjacent the electronic display device and includes a first portion positioned adjacent the image-displaying portion of the display device and a second portion positioned adjacent the other portion of the display device. The optical properties of the first and second portions of the cover are selected to present an appearance of a uniform cover without a bezel when the display device is not displaying an image. The optical properties of the first portion are also selected to transmit images displayed on the image-displaying portion. Preferably, the optical properties of the second portion are selected to mask the other portion of the display device. A secondary display device may also be provided that presents an image, such as a logo, independently of whether the other or main electronic display device is displaying an image.

(21) Appl. No.: **10/300,648**

(22) Filed: **Nov. 20, 2002**

Related U.S. Application Data

(63) Continuation-in-part of application No. 29/166,842, filed on Sep. 3, 2002.
Continuation-in-part of application No. 29/166,843, filed on Sep. 3, 2002.
Continuation-in-part of application No. 29/166,844, filed on Sep. 3, 2002.

Publication Classification

(51) **Int. Cl.⁷ H01K 1/26; H01J 31/00**

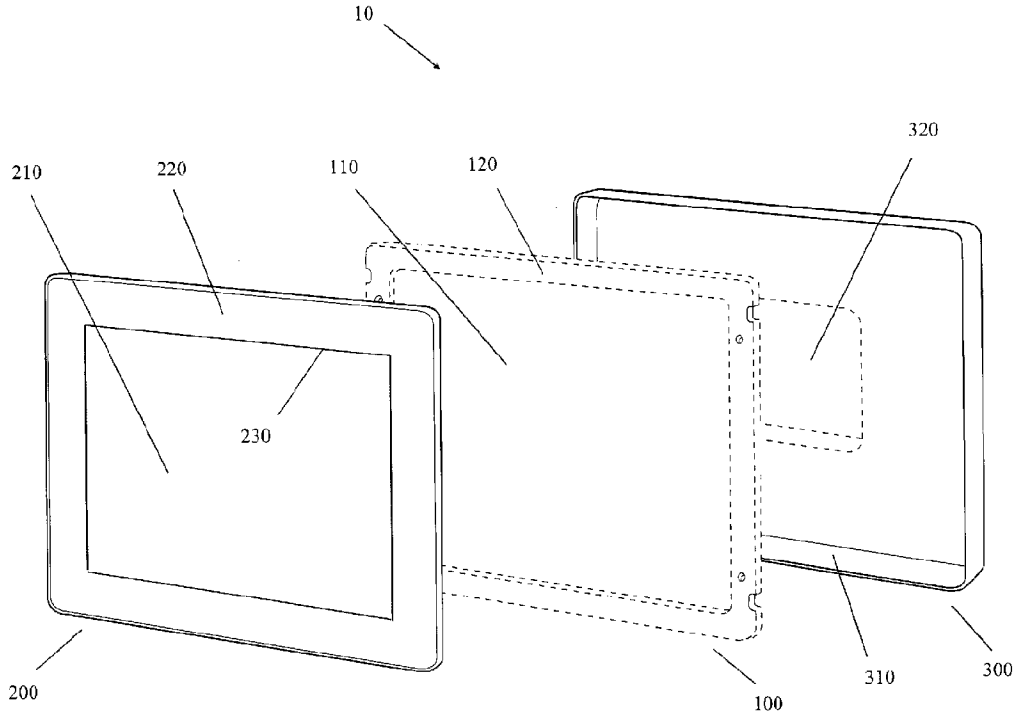

DEFENDANT'S EXHIBIT
NO. 678.001
United States District Court
Northern District of California
No. 11-CV-01846-LHK (PSG)
Apple v. Samsung
Date Admitted: _____ By: _____

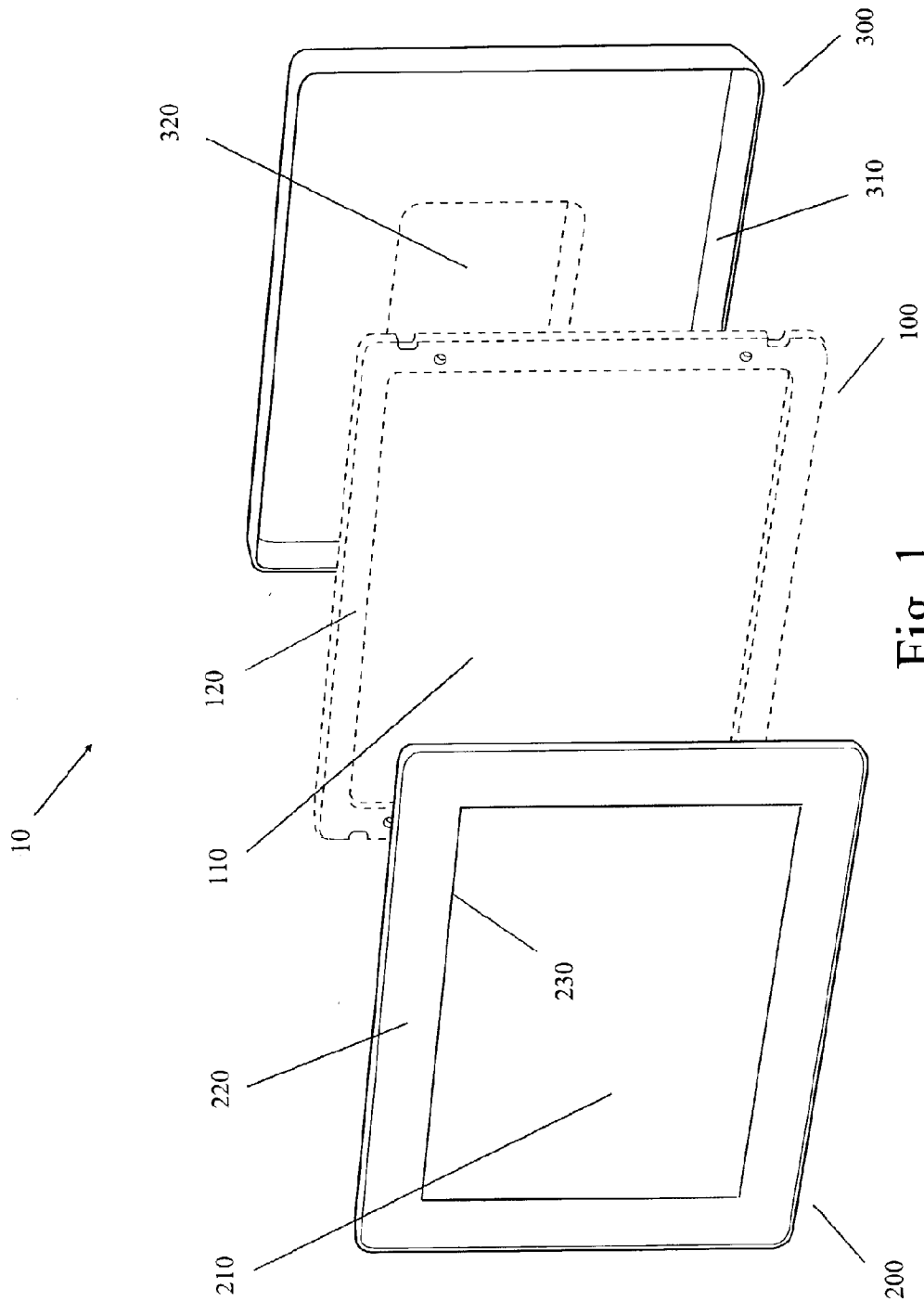

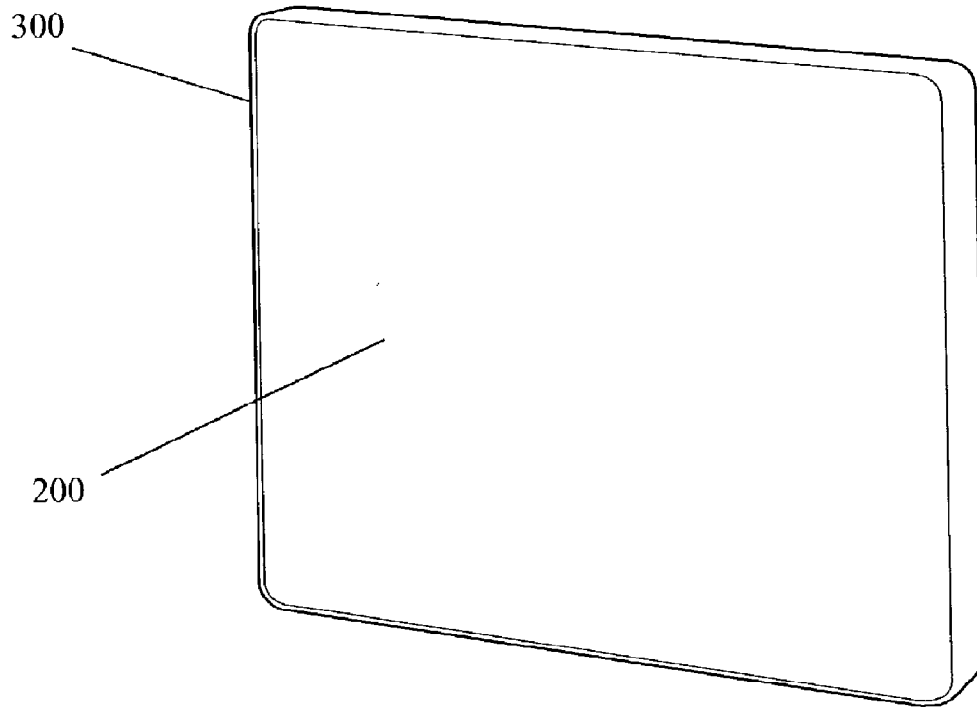
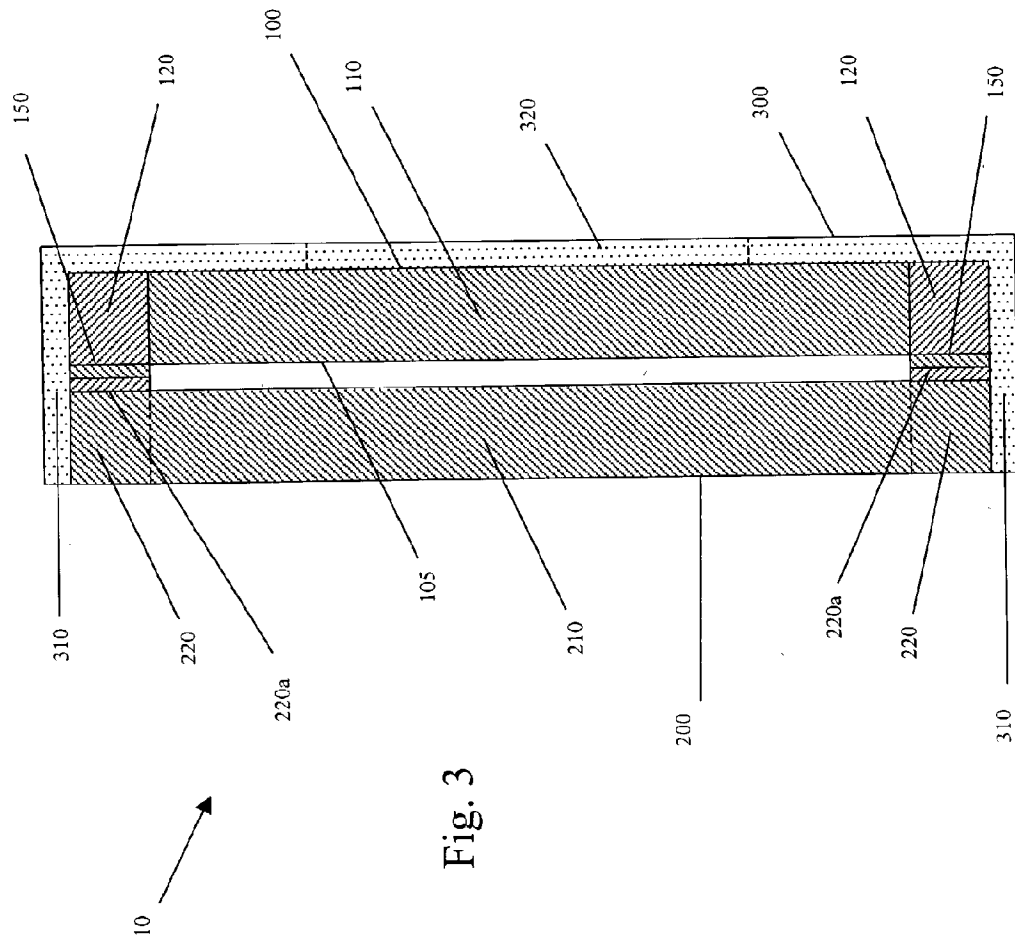

Fig. 2



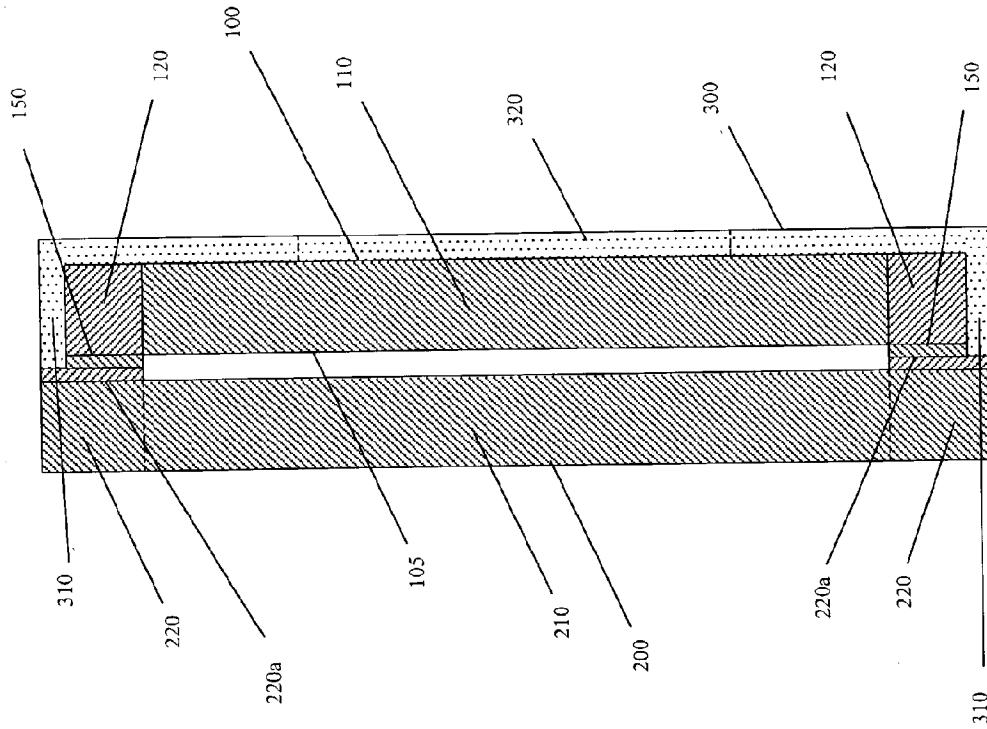

Fig. 4

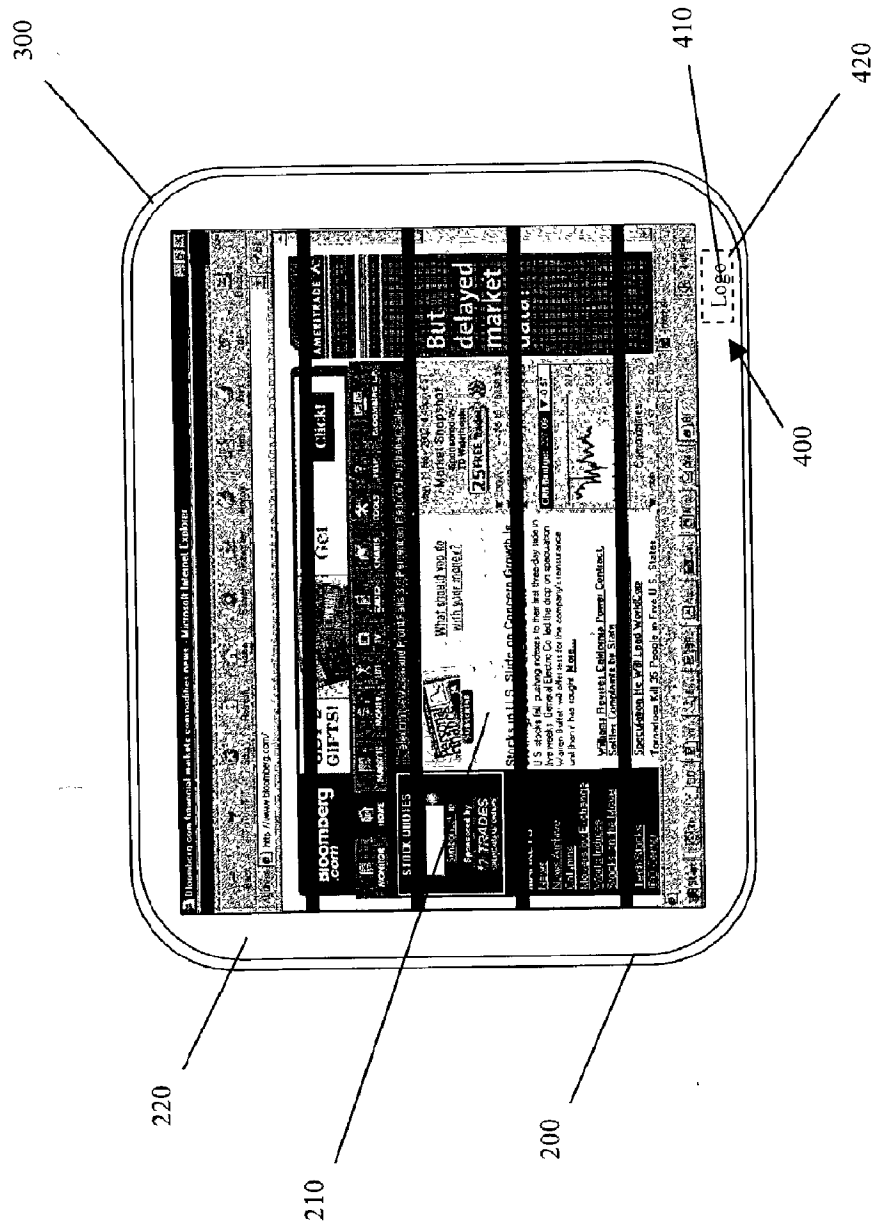

Fig. 5

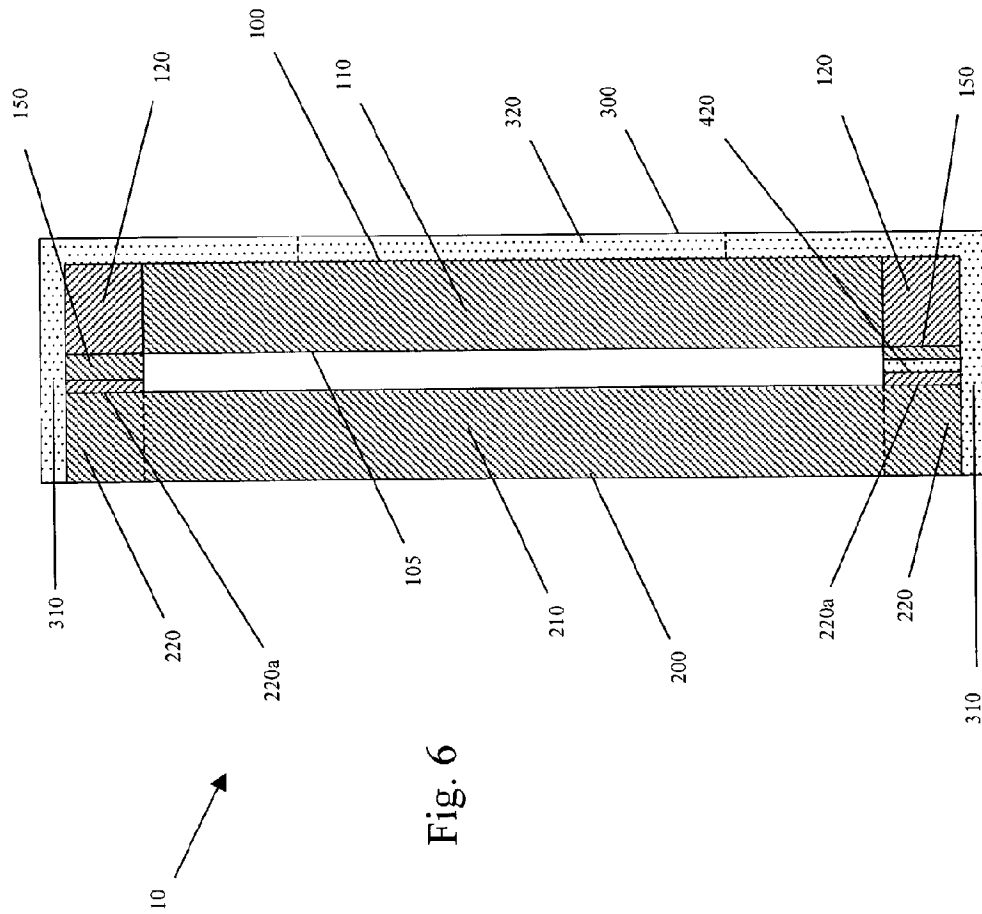

Fig. 6

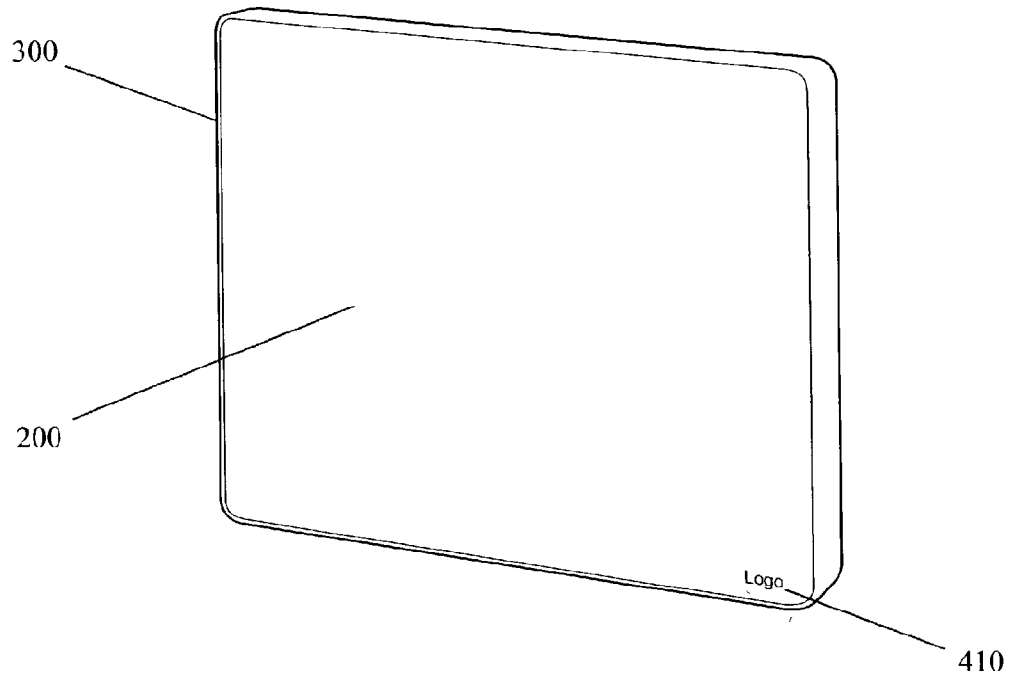

Fig. 7

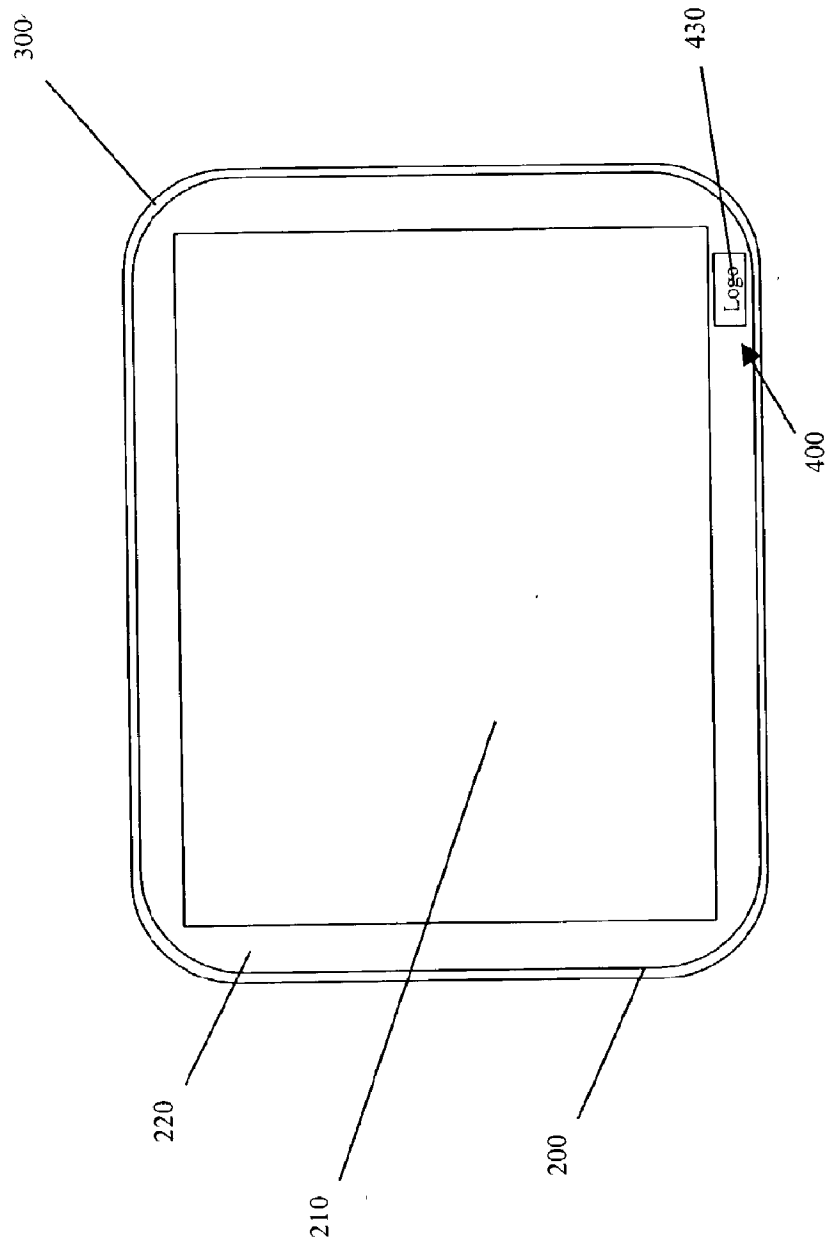

Fig. 8

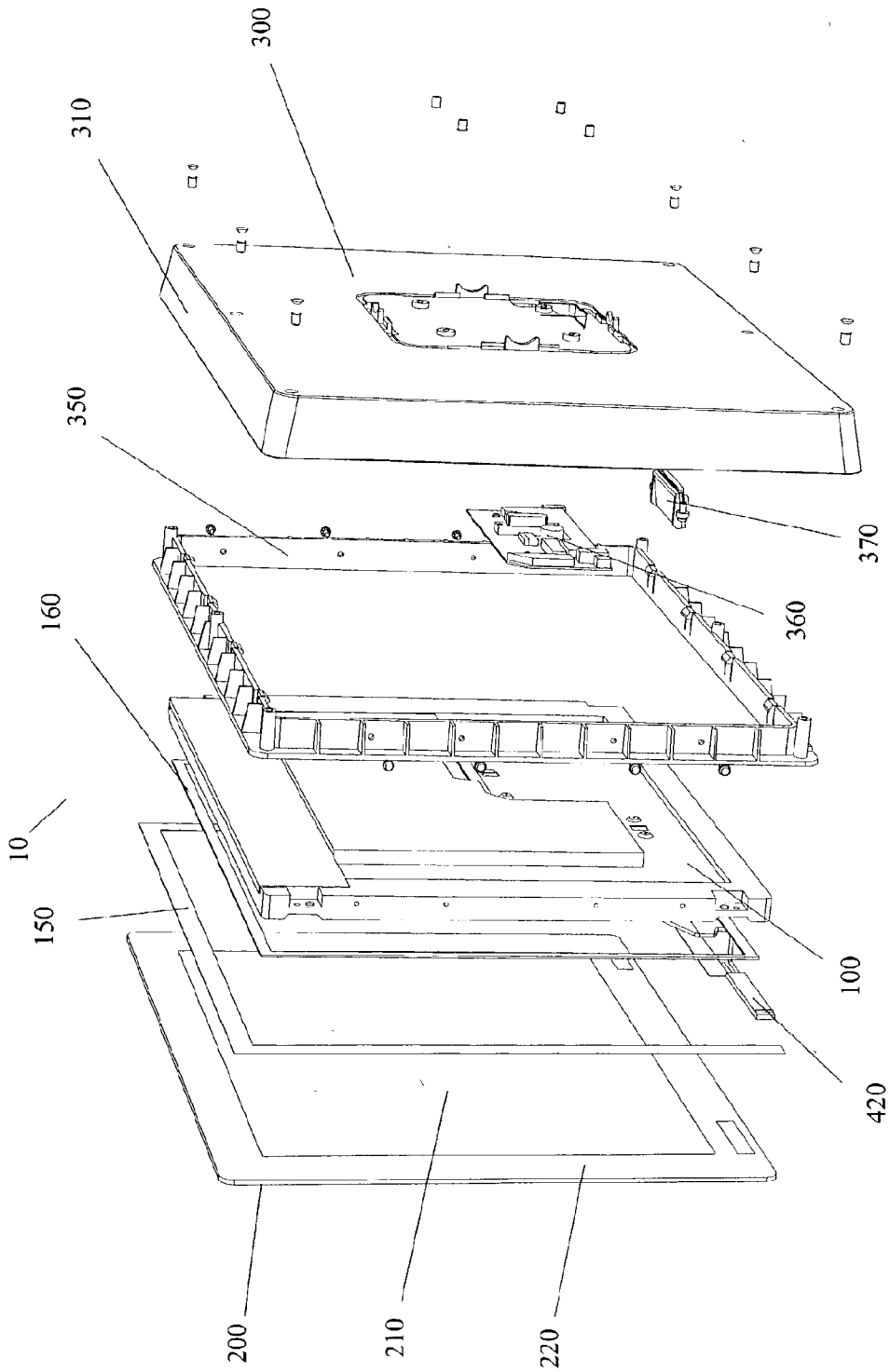

Fig. 9

Patent Application Publication Mar. 4, 2004 Sheet 10 of 10 US 2004/0041504 A1

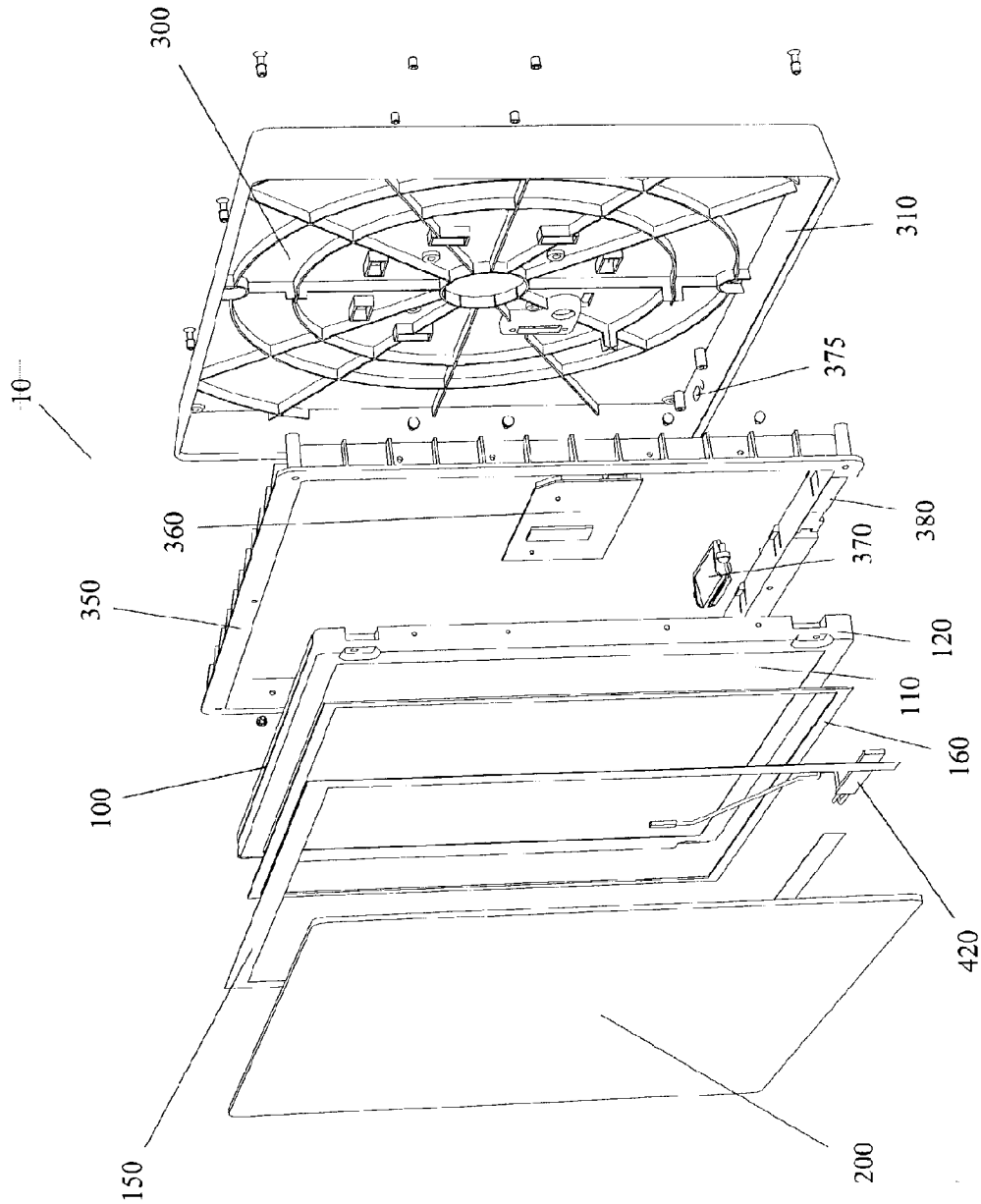

Fig. 10

US 2004/0041504 A1

Mar. 4, 2004

1

BEZEL-LESS ELECTRONIC DISPLAY

CROSS-REFERENCE TO RELATED APPLICATIONS

[0001] This application is a continuation-in-part and claims priority of U.S. Design Application, Serial No. 29/166,842, U.S. Design Application, Serial No. 29/166,843, and U.S. Design Application, Serial No. 29/166,844, all of which were filed on Sep. 3, 2002, and all of which are hereby incorporated by reference into this application.

COPYRIGHT NOTICE

[0002] A portion of the disclosure of this patent document contains material which is subject to copyright protection. The copyright owner has no objection to the facsimile reproduction by anyone of the patent document or the patent disclosure, as it appears in the Patent and Trademark Office patent files or records, but otherwise reserves all copyright rights whatsoever.

BACKGROUND OF THE INVENTION

[0003] The invention disclosed herein relates generally to electronic displays. More particularly, the present invention relates to an electronic display without a bezel, i.e., a bezel-less electronic display.

[0004] Electronic displays, such as flat panel monitors used with computers or flat panel televisions, generally have a bezel or frame surrounding a display screen or portion of the electronic display.

SUMMARY OF THE INVENTION

[0005] The invention provides a bezel-less electronic display comprising an electronic display device having an image-displaying portion and a cover positioned adjacent the electronic display device that are mounted in an assembly without a bezel. The cover may also be referred to as a lens in the context of an electronic display. However, such lenses typically do not refringe (e.g., focus or diverge) light. The cover overlays the image-displaying portion of the display device and forms a front of the electronic display. The cover also overlays any portion of the display device outside of the image-displaying portion that is visible from the viewing side or front of the electronic display. Thus, the front of the display is presented as a cover without a bezel. Preferably, the cover and the display device are mounted to an enclosure which forms the rear and side of the electronic display. The cover and display device may be mounted or assembled into an assembly in any suitable manner, some of which, including preferred embodiments, are disclosed herein. Also, the cover, display device and enclosure, may be mounted or assembled into an assembly in any suitable manner, some of which, including preferred embodiments, are disclosed herein. For example, the cover and display device may be assembled into a sub-assembly and this sub-assembly may be mounted in an enclosure to form an assembly.

[0006] As discussed herein, electronic display devices typically include another portion outside of and at the periphery of the image-displaying area, which function as a frame or support for the display device, or perform other functions. The cover overlays the image-displaying portion and the other portion of the display device. Thus, the cover

provides that portion of the electronic display that is exposed to or faces a user viewing the electronic display, i.e., provides in a bezel-less fashion the front of the electronic display.

[0007] Depending upon parameters selected for the cover, different bezel-less effects may be provided. For example, a flat cover, which is preferred, presents a flat, bezel-less front. However, other configurations may be used depending upon the effect desired. For example, curved configurations may be used. Such curved configurations are curved in the sense that the cover has a curved outer surface. Configurations that have other surface structures may also be used. Regardless of the cover configuration, the cover is mounted in a bezel-less fashion as described herein.

[0008] The cover includes at least a first and second portion, with the first portion overlaying the image-displaying portion and the second portion overlaying the other portion of the display. The portions of the cover overlaying the image-displaying portion and the other portion of the display preferably have optical properties selected to provide a desired appearance across the cover when no image is being displayed by the image-displaying portion (e.g., when the image-displaying portion is darkened or presents a screen of a given color), or when an image is being displayed by the image-displaying portion (e.g., a graphic or text image), or both. The optical properties of first portion are also selected with regard to transmission of images there-through from the image-displaying portion of the display device, for example to provide for a high transmissivity.

[0009] The optical properties of the portions of the cover overlaying the image-displaying portion and the other portion of the display device can be selected so that the portions present a uniform appearance when the display device is not displaying an image. In the preferred embodiment, the optical properties are selected to provide a uniform darkened appearance across both portions of the cover when the image-displaying portion is darkened. The optical properties of the two portions can be selected to also provide a desired effect when the display device is displaying an image. For example, the optical properties of the portion of the cover overlaying the other portion of the display device can be selected to provide a border of a desired color which partially or completely masks, obscures or otherwise reduces the visibility of the other portion of the display device.

[0010] Regardless of the optical properties of the portion of the cover overlaying the other portion of the display device, a flat cover in accordance with the invention provides a flush or flat appearance due to elimination of a bezel. However, covers having configurations other than flat can provide other bezel-less appearances. The optical properties of the portion of the cover overlaying the other portion of the display device may be selected to present a desired border appearance, particularly when the display device is displaying an image. In the preferred embodiment, the portion of the cover overlaying the other portion is opaque, and the color of the opaque portion may be selected to provide a desired appearance. Cover properties such as shape, configuration, size, etc., may also be selected to provide a desired bezel-less effect.

[0011] In a preferred embodiment of the invention, the optical properties of the second portion of the cover are also

SAMNDCA00027703

US 2004/0041504 A1

Mar. 4, 2004

2

selected to partially or completely mask or obscure or otherwise reduce the visibility therethrough of the other portion of the display device. This may be achieved where the second portion has low transmissivity or is opaque, e.g., has an opaque coating. In this embodiment, the second portion presents a border or frame appearance. With a flat cover, the frame or border appears flush with any image being presented by the image displaying portion of the display device. In a preferred embodiment of the invention, the second portion of the cover comprises opaque material having the same red, green, and blue color values as the image-displaying portion of the display device when no image is displayed thereon. This provides the effect of a borderless, frameless and bezel-less front when the display device is not displaying an image.

[0012] In one embodiment, the second portion of the cover surrounds and is coplanar with the first portion, i.e., together they form a flat cover. Preferably, the flat cover comprises a sheet including the first and second portions, i.e., the first and second portions of the cover form different regions of the sheet. In a preferred embodiment of the invention, the first portion of the sheet comprises a tint and the second portion is opaque, e.g., has an opaque coating. The second portion may also comprise a tint, the same or different from the tint of the first portion. Preferably the tint of the first and second portions is the same so that a sheet with a uniform tint may be provided, and the sheet is provided with an opaque coating on the second portion. The tint, at least for the first portion, is preferably a neutral tint, e.g., a neutral gray tint, that does not noticeably alter the color of images transmitted through the first portion. Tinting and/or coating as disclosed herein may also be applied to covers that are not a sheet.

[0013] The invention also provides a composite electronic display comprising a main display device and secondary display device. The main display device may be conventional, or may comprise the inventive electronic display disclosed herein. The secondary display device presents one or more images independently of the main display device, with the image(s) being presented outside of an image-displaying portion of the main display device. In one embodiment, the secondary display device generates a single, fixed image, such as a corporate logo, advertisement, licensed character, personalized image or message, etc.

[0014] The secondary display device preferably displays an image both when the main display device is displaying an image and when the main display device is not displaying an image, e.g., when the main display device is darkened or off altogether. The image presented by the secondary display device is displayed even when no power is provided to the main display device. For example, the secondary display device may display its image as long as outside power is provided to the composite electronic display or as long as battery power is supplied to the secondary display device.

[0015] In accordance with a preferred embodiment of the invention, the composite electronic display comprises a bezel-less electronic display, as disclosed herein, and a secondary display device positioned to provide its image(s) in the second portion of the cover. The secondary display device comprises a light source and structure defining an image. For example, the light source can be a light emitter such as an LED or lamp, and the image-defining structure

can be a part of the second portion of the cover having contrasting optical properties that define the image. In this embodiment, the image is fixed. Alternatively, the light source can be an LCD or other display device that includes structure for generating an image, fixed, changeable or dynamic. The LCD or other display device can also generate a fixed image by providing light therefrom to contrasting optical properties in the second portion of the cover as disclosed herein.

[0016] The invention also provides a method for providing a bezel-less electronic display. The method comprises mounting or assembling a cover, having first and second portions, with a display device including an image-displaying portion and another portion extending along at least a portion of a side thereof, so that the first portion of the cover overlays the image-displaying portion and the second portion of the cover overlays the other portion of the display device; and selecting the optical properties of the first and second portions so that the cover presents a desired appearance when the image-displaying portion of the display device is not displaying an image. The optical properties may also be selected so that the cover presents a desired border appearance when the image-displaying portion is displaying an image.

BRIEF DESCRIPTION OF THE DRAWINGS

[0017] The invention is illustrated in the figures of the accompanying drawings which are meant to be exemplary and not limiting, in which like references are intended to refer to like or corresponding parts, and in which:

[0018] FIG. 1 is an exploded perspective view of an electronic display in accordance with an embodiment of the invention;

[0019] FIG. 2 is a perspective view of the electronic display depicted in FIG. 1 when no image is displayed;

[0020] FIG. 3 is a schematic cross-sectional side view of the electronic display depicted in FIG. 1;

[0021] FIG. 4 is a schematic cross-sectional side view of an embodiment of the electronic display in accordance with the invention;

[0022] FIG. 5 is a front view of a composite electronic display in accordance with an embodiment of the invention;

[0023] FIG. 6 is a schematic cross-sectional side view of the composite electronic display depicted in FIG. 5;

[0024] FIG. 7 is a perspective view of a composite electronic display in accordance with an embodiment of the invention;

[0025] FIG. 8 is a front view of another embodiment of a composite electronic display in accordance with the invention;

[0026] FIG. 9 is an exploded perspective view of an electronic display in accordance with an embodiment of the invention; and

[0027] FIG. 10 is an exploded perspective view of an electronic display in accordance with an embodiment of the invention.

DETAILED DESCRIPTION OF THE PREFERRED EMBODIMENTS

[0028] According to a preferred embodiment of the invention depicted in FIG. 1, the electronic display 10 comprises

US 2004/0041504 A1

Mar. 4, 2004

3

an electronic display device **100**, a cover **200** and an enclosure **300** to which the display device **100** and the cover **200** are mounted. (Some of the components shown in the figures are exaggerated and shown somewhat schematically for purposes of explanation, and may not be to scale.)

[0029] The electronic display device **100** may be conventional and may comprise any device capable of generating and presenting images to a user, such as, for example, an LCD panel. An example of an electronic display device that may be used with the invention is the TFT LCD Model LTM170EI from Samsung Electronics Co., Ltd.

[0030] The electronic display device **100** (FIG. 1) includes an image-displaying portion on which images generated by the display device are presented to a user. For example, the image-displaying portion **110** of display device **100** may comprise the display area of an LCD panel. The side of the display device **100** on which images are presented to a user may be referred to as the front of the device.

[0031] The electronic display device **100** (FIG. 1) also includes another portion **120** that is visible from the front of the display device **100**, e.g., viewable by a user looking at the front of display device **100**. The other portion **120** may comprise any component part or parts of display device **100** other than the image-displaying portion **110** that are visible from the front of display device **100**, e.g., a frame or support for the display device to support the display device or for mounting the display device, or for other purposes. In the embodiment depicted in FIG. 1, the other portion **120** extends adjacent and surrounds the image-displaying portion **110**. The other portion **120** may be configured and located other than as shown in FIG. 1 depending upon the particular display device.

[0032] For example, where display device **100** (FIG. 1) is an LCD, the other portion **120** is referred to as the LCD frame, that may serve a variety of functions, such as, for example, those described above. Where the display device **100** is an LCD, the portion **120** may contain holes, as shown for example in FIG. 1, for mounting screws that attach the display device to the enclosure **300**.

[0033] Referring to FIG. 1, the cover **200** includes at least a first portion **210** and a second portion **220**. A line **230** illustrates the demarcation of the first and second portions **210**, **220**. However, the line **230** and the demarcation may not be visible, depending upon lighting conditions behind the cover **200**. For example, with the cover **200** mounted to the display device **100**, and the display device **100** not displaying an image, e.g., having a darkened image displaying portion **110**, line **230** is not visible, and the cover **200** has a uniform appearance as shown in FIG. 2. On the other hand, when the display device **100** is displaying an image, e.g., is projecting light in the form of an image, the image will be visible in portion **210** of cover **200**, and line **230** will appear as a demarcation between portions **210** and **220**, with portion **220** appearing as a flush border to the image appearing in cover portion **210**. FIG. 5 depicts the display **10** displaying an image surrounded by a flush border **220**, which is shown uncolored but in the preferred embodiment is darkened.

[0034] The first and second portions of the cover **200** are sized, and the cover **200** is positioned adjacent to the front side of the electronic display device **100** with the first

portion **210** of cover **200** positioned adjacent and at least coextensively with the image-displaying portion **110** of display device **100**, and with the second portion **220** of cover **200** positioned adjacent and at least coextensively with the portion **120** of display device **100**. The size relationship of the first and second portions **210**, **220** of the cover **200** is preferably identical or substantially similar to the size relationship of the image-displaying portion **110** and the other portion **120** of the display device **100**. In the embodiment depicted in FIG. 1, the second portion **220** of cover **200** surrounds the first portion **210**.

[0035] The first portion **210** and second portion **220** of cover **200** each have optical properties selected such that, (a) when images are displayed on image-displaying portion **110** of the electronic display device **100**, the displayed images are suitably transmitted through the first portion **210** so as to be visible to a user, and may have a flush border or frame **220**, as illustrated in FIG. 5 and, (b) when no images are displayed on the image-displaying portion **110**, the first portion **210** and second portion **220** of cover **200** present a uniform appearance such that they present a flush uniform front of the electronic display **100** without a bezel, as illustrated in FIG. 2.

[0036] In a preferred embodiment of the invention, the optical properties of second portion **220** are selected so as to completely mask images of other portion **120** and any objects and materials attached to portion **120**, and thus prevent them from being transmitted through second portion **220** and being seen by a user. In this embodiment, cover **200** may comprise any suitable structure capable of transmitting light, such as, for example, a glass or plastic sheet, with portions **210** and **220** forming different regions of the sheet. Portions **210** and **220** are provided with optical properties, e.g., tinting, or coloring, or coating(s) such that (a) images of other portion **120** of display device **100** and any objects and materials attached to portion **120** are not visible through second portion **220**, and, (b) when images are displayed on image-displaying portion **110** of the electronic display device **100**, the displayed images are transmitted through the first portion **210** so as to be visible to a user, and, (c) when no images are displayed on the image-displaying portion **110**, the first portion **210** and second portion **220** of cover **200** present a uniform appearance such that they appear to be a single, flush front or cover without a bezel.

[0037] The optical properties above may be imparted to second portion **220** of cover **200** by, for example, applying a layer or coating of opaque material, e.g., paint or ink, to the structure comprising cover **200** in the region of second portion **220**. In the preferred embodiment, the color of the opaque material is selected so as to match the appearance of image-displaying portion **110** of display device **100** when no images are displayed thereon. This may be accomplished by, for example, obtaining the red, green, and blue color values of the image-displaying portion **110** of display device **100** when no images are displayed thereon, e.g., using a colorimeter, and selecting an opaque material having the same color values.

[0038] First portion **210** of cover **200** may be tinted or colored to impart optical properties as described above. In the preferred embodiment, tinting is provided having characteristics that are selected so that, when images are displayed on image-displaying portion **110** of the electronic

US 2004/0041504 A1

Mar. 4, 2004

4

display device **100**, the displayed images are suitably transmitted, e.g., at 80% transmissivity, through the first portion **210** so as to be visible to a user, and yet, when no images are displayed on the image-displaying portion **110**, the tint provides an appearance of first portion **210** that matches the appearance of the opaque material applied to second portion **220**, which together present the uniform appearance described herein.

[0039] In the preferred embodiment, the electronic display device **100** is an LCD panel, and the above described optical properties of the cover can be achieved using an acrylic plastic sheet as cover **200**. (An acrylic sheet is sometimes referred to as a lens, although the sheet does not refringe light (e.g., focus or diverge light) as would a lens.) The acrylic sheet is preferably provided with an anti-glare coating (e.g., having a gloss level of **44**) and a scratch-resistant coating. Such coatings are known in the art. The second portion **220** of the plastic sheet includes a paint coating **220a** having a color of standard black as the opaque material forming part of the second portion **220**. The first portion **210** includes a tint or coloring tint that does not noticeably alter colors of an image transmitted through portion **210**. For example, the first portion **210** may comprise a neutral gray tint (e.g., smoked tint #2064) and be about 80% transmissive.

[0040] The assembly depicted in FIG. 3 includes the cover **200**, the display device **100** and the enclosure **300**. The second portion **220** of the cover is shown with a coating or layer of opaque material **220a**. The assembly also includes an adhesive or bonding agent **150** which attaches the cover **200** to the display device **100**. The display device is mounted to the enclosure by screws passing through the rear of the enclosure and engaging threaded holes (see FIG. 1) in the frame **120** of the display device. Enclosure **300** comprises a side wall **310** of sufficient height to accommodate at least the thickness of electronic display device **100** and the cover **200**. In another embodiment depicted in FIG. 4, the cover is not accommodated within the enclosure but outside the enclosure, as discussed in more detail below. An opening **320** at the rear of enclosure **300** may be provided so as to allow access to the rear of electronic display device **100**, where, for example, input and output connectors may be located.

[0041] Although the first portion **210** and the second portion **220** are shown in FIG. 1 and described above as separate regions of a single structure comprising cover **200**, the portions **210** and **220** may be separate pieces. For example, in an embodiment of the invention, first portion **210** and second portion **220** each may be distinct structures attached in any suitable manner together to form cover **200**. In such an embodiment, portions **210** and **220** may be shaped and attached together using known procedures, which may include filling any gaps between the two portions or otherwise providing a desired flush appearance, such that portions **210** and **220** present a bezel-less cover.

[0042] Cover **200** may be mounted directly or indirectly (e.g., using a plastic frame as described below) to electronic display device **100** or enclosure **300** in any suitable manner that provides a secure attachment. It is preferred that a fastenless system be used so that fasteners are not visible from the cover **200**. For example, cover **200** may be attached to display device **100**, by an adhesive or thermal or acoustic bonding, so that cover **200** and display device **100** together

form a sub-assembly. In the preferred embodiment, VHB™ Acrylic Foam Tape from the 3M™ Company is used. As shown in FIG. 3, the VHB™ tape **150** may be used to mount cover **200** to electronic display device **100**. As assembled, the tape is between the portion **120** of the display device **100** and portion **220** of cover **200** and adheres the two. The tape may first be adhered to the portion **110** of the display device and then the portion of **220** of the cover **200** is adhered to the other side of the tape, or vice versa.

[0043] The sub-assembly of the cover **200** adhered to display device **100** using the VHB tape, as described above, may be mounted to enclosure **300** by placing the sub-assembly into enclosure **300** (or vice versa) so that cover **200** is flush with the raised edge **310** of enclosure **300** and then fixing the sub-assembly to enclosure **300** using mounting screws placed through holes in enclosure **300** and into the other portion **120** of display device **100**.

[0044] Alternatively, as discussed above, cover **200** may be sized and the sub-assembly comprising cover **200** adhered to display device **100** may be mounted to enclosure **300** such that cover **200** lies on top of the edge of side wall **310** of enclosure **300** flush with the periphery thereof, as shown in FIG. 4. In this an embodiment, second portion **220** of cover **200** covers side wall **310** of enclosure **300** as well as the other portion **120** of display device **100**. The sub-assembly may be fixed to enclosure **300** in the same manner as described above using screws entering the electronic display **10** from the rear of the enclosure **300**.

[0045] Where portion **220** has optical properties that completely mask whatever is behind it, then, when images are displayed on image-displaying portion **110** of display device **100**, portion **220** appears as an opaque, flush border or frame for portion **210**. Unlike conventional displays, with a bezel that protrudes from the display screen, portion **220** is part of or appears to be part of the same structure comprising portion **210**, and does not protrude from portion **210**, but rather is flush or coplanar with portion **210**.

[0046] FIG. 5 depicts an embodiment of the invention that includes a secondary display device **400** that presents one or more images (represented by "Logo") independently of display device **100**, which is referred to as the main display device in this embodiment. In one embodiment, the secondary display device **400** comprises an area **410** of the second portion **220** of cover **200** that is modified to form an image, such as, for example, a corporate logo, advertisement, licensed character, or personalized image or message, etc., and a light source **420** located behind this area **410** that transmits light through area **410** to present the image.

[0047] Where the second portion **220** of cover **200** includes an opaque coating **220a** (FIG. 3), area **410** may be formed by, for example, omitting opaque material in the form of the image. For instance, where paint is used as the layer of opaque material and is applied to second portion **220**, any suitable masking or etching process may be employed.

[0048] The light source **420** may be any suitable source of light, such as an LCD or an LED. In the preferred embodiment, an LED assembly of the type commercially available from Global Lighting Technologies, Inc., as, e.g., the Micro-Lens™ LED, is used. The assembly is mounted behind the area **410** in any manner suitable to fix it securely between the

US 2004/0041504 A1

Mar. 4, 2004

5

cover **200** and the other portion **120** of the display device, and to direct light to area **410**. For example, an adhesive or other bonding system, or fasteners, may be used to attach the light assembly **420** to the frame **120** of the display device **100**. In the preferred embodiment, the light assembly **420** may be mounted by adhering it to the VHB™ tape placed on other portion **120** of the display device **100** at the position behind area **410**, as shown in FIG. 6. Since the VHB™ tape is compliant, the assembly **420** may be depressed into the VHB™ tape so that, when the cover **200** is adhered to the VHB™ tape and the other portion **120** of display device **100**, the VHB™ tape forms a seal around the assembly **420** that prevents light from the LED from leaking into the area behind the first portion **210** of cover **200** that may otherwise be visible to a user or an observer. If desired, a foam gasket may be placed around the assembly **420** to ensure that no light leaks from the LED. The light source is powered by known means independently of the electronic display device **100** and can remain on even when the display device **100** is off or in an inactive "sleep" mode. For example, the power can be derived from the AC lines (as long as the display remains connected to AC power), or by battery power.

[0049] The portions of area **410** that do not form the image preferably have the same optical properties as portion **210**. Thus, as shown in FIG. 7, when no images are presented on image-displaying portion **110** of display device **100**, portions **210** and **220** of cover **200** present a uniform appearance as described above, except for the image presented by secondary display **400**. In another embodiment of the invention, shown in FIG. 8, the image presented by the secondary display device **400** comprises a plate or cover **430** mounted on the exposed side of cover **200** overlying adjacent a light source (not shown), as described above. The image on plate or cover **430** may be formed as described above. The plate or cover **430** may also be mounted on the inside of cover **200** which then includes a light transmitting section in portion **220** overlaying the plate.

[0050] Another embodiment of the invention is shown in FIGS. 9 and 10. An electronic display **10** comprises an electronic display device **100**, a cover **200**, and an enclosure **300**, as previously described above. The display device **100** fits into a plastic frame **350** and is attached thereto by any suitable means, such as, for example, screws entering the sides of the frame **350** and into the sides of the other portion **120** of display device **100**. Attached to the front of the display device **100**, on other portion **120**, is a dust gasket **160**. Dust gasket **160** may be attached to other portion **120** by any suitable means, such as, for example, an adhesive. A light assembly **420**, as described previously, fits into a notch **380** at a location within the frame **350** beneath the display device **100**. The light assembly **420** may be attached to the frame **350** at notch **380** by any suitable means, such as, for example, an adhesive. Cover **200** is bonded to frame **350** in any suitable manner, such as, for example, using VHB™ tape **150**, as described previously. A printed circuit board ("PCB") **360**, providing power and input and output connections, attaches to the back of display device **100** in any suitable manner, such as, for example, fasteners, e.g., screws, or an adhesive. A button mounting board **370** mounts under the frame **350** in any suitable manner, such as, for example, using an adhesive, and provides buttons for controlling the display device **100**, e.g., on/off and brightness buttons. Buttons from the button mounting board **370** extend down through holes **375** in a bottom sidewall **310** of

enclosure **300** where they may be accessed by a user. The components above, i.e., frame **350**, display device **100**, dust gasket **160**, cover **200**, light assembly **420**, PCB board **360**, and button mounting board **370** form a sub-assembly that is then mounted to enclosure **300** in any suitable manner, such as, for example, screws entering through the back of enclosure **300** and into the back of frame **350**.

[0051] While the invention has been described and illustrated in connection with preferred embodiments, many variations and modifications as will be evident to those skilled in this art may be made without departing from the spirit and scope of the invention, and the invention is thus not to be limited to the precise details of methodology or construction set forth above as such variations and modification are intended to be included within the scope of the invention.

What is claimed is:

1. An electronic display without a bezel, comprising.
 - a) an electronic display device having an image-displaying portion and another portion adjacent the image-displaying portion along at least one side; and
 - b) a cover positioned adjacent the electronic display device, the cover including a first portion having optical properties positioned adjacent the image-displaying portion of the display device and a second portion having optical properties positioned adjacent the other portion of the display device, the optical properties of the first and second portions of the cover being selected to present an appearance of a uniform cover without a bezel when the display device is not displaying an image, the optical properties of the first portion also being selected with regard to transmission therethrough of images displayed on the image-displaying portion of the electronic display device.
2. The electronic display of claim 1, wherein the optical properties of the second portion are selected to substantially reduce visibility of the other portion of the display device.
3. The electronic display of claim 1, wherein the second portion is opaque.
4. The electronic display of claim 1, wherein the second portion comprises an opaque coating.
5. The electronic display of claim 3, wherein the second portion comprises an opaque material having the same red, green, and blue color values as the image-displaying portion when no images are displayed thereon.
6. The electronic display of claim 1, wherein the first portion comprises a tint.
7. The electronic display of claim 1, wherein the cover includes a single sheet of plastic with the first and second portions forming different regions of the sheet.
8. The electronic display of claim 7, wherein the first portion comprises a neutral tint so as to reduce alteration of the color values of images transmitted through the first portion.
9. The electronic display of claim 7, wherein the second portion comprises an opaque coating.
10. The electronic display of claim 1, wherein the electronic display device comprises a liquid crystal device.
11. The electronic display of claim 1, wherein the cover has a flat outer shape.

US 2004/0041504 A1

Mar. 4, 2004

6

12. An electronic display without a bezel, comprising:
an electronic display device having an image-displaying portion and another portion adjacent the image displaying portion;
a cover having a first portion that is light transmitting; and
an enclosure having an open end, the electronic display device being mounted in the enclosure and the cover closing the open end of the enclosure without a bezel with the first portion of the cover overlaying the image-displaying portion of the display device.

13. The display of claim 12, wherein the cover includes a second portion surrounding the first portion positioned to overlay the other portion of the electronic display device, the first and second portions having different optical properties.

14. The display of claim 13, wherein the optical properties of the second portion of the cover are selected to partially or completely mask the other portion of the electronic display device.

15. The display of claim 14, wherein the optical properties of the first and second portions are selected to present a uniform appearance when the image-displaying portion is not displaying an image.

16. A display apparatus comprising:

a main display device having an image-displaying portion; and

a secondary display device that presents at least one image outside of and at the periphery of the image-displaying portion of the main display device independently of whether the main display device is displaying an image.

17. An electronic display without a bezel, comprising:

a main electronic display device having an image-displaying portion and another portion adjacent the image-displaying portion along at least one side;

a cover positioned adjacent the main electronic display device, the cover including a first portion having optical properties positioned adjacent the image-displaying portion of the main display device and a second portion having optical properties positioned adjacent the other portion of the display device, the optical properties of the first and second portions of the cover being selected to present an appearance of a uniform cover without a bezel when the display device is not displaying an image, the optical properties of the first portion also being selected with regard to transmission therefrom of images displayed on the image-displaying portion; and

a secondary display device that presents at least one image in an area located within the second portion of the cover independently of whether the main display device displays an image.

18. The electronic display of claim 17, wherein the secondary display device presents a fixed image.

19. The electronic display of claim 17, wherein the secondary display device presents at least one logo.

20. The electronic display of claim 17, wherein the secondary display device comprises a light source and structure defining a fixed image.

21. The electronic display of claim 17, wherein the light source of the secondary display device comprises a liquid crystal device.

22. The electronic display of claim 17, wherein the light source of the secondary display device comprises a light emitting diode.

23. The electronic display of claim 21, wherein the structure defining the fixed image presented by the secondary display device comprises contrasting optical properties defining the fixed image overlaying the light source.

24. The electronic display of claim 21, wherein the light source comprises a liquid crystal device and the structure defining the fixed image comprises part of the liquid crystal device.

25. A method for providing a bezel-less electronic display, comprising:

assembling a cover, having first and second portions with a display device including an image-displaying portion and another portion extending along at least a portion of a side thereof, so that the first portion of the cover overlays the image-displaying portion and the second portion of the cover overlays the other portion of the display device; and

selecting the optical properties of the first and second portions so that the cover presents a uniform appearance when the image-displaying portion of the display device is not displaying an image.

26. An electronic display without a bezel, comprising:

an electronic display device having an image-displaying portion and another portion adjacent the image-displaying portion along at least one side; and

a cover mounted in an assembly including the electronic display device and positioned adjacent the electronic display device, the cover including a first portion having optical properties positioned adjacent the image-displaying portion of the display device and a second portion having optical properties positioned adjacent the other portion of the display device, the optical properties of the first and second portions of the cover being selected to present an appearance of a uniform cover without a bezel when the display device is not displaying an image, the optical properties of the first portion also being selected with regard to transmission therethrough of images displayed on the image-displaying portion of the electronic display device.

27. The electronic display of claim 26, comprising an enclosure having an open end in which the electronic display device is mounted with the cover closing the open end of the enclosure without a bezel.

28. The electronic display of claim 27, wherein the cover is attached to the electronic display device and forms all or part of the assembly.

29. The electronic display of claim 28, wherein the assembly also include the enclosure.

30. The electronic display of claim 26, comprising a separate frame attached to the display device, the cover separate frame and the display device being attached and forming all or part of the assembly.

31. The electronic display of claim 30, comprising an enclosure forming a part of the assembly, the enclosure having an open end closed by the cover without a bezel.

* * * * *